

**Ricon Application Chart
Ford Econoline Body Style
1992 and Up E-Class**



Ricon Application Chart

Lifts for Standard and Modified Vans

1992- and up E-Class
Body Style FORD



INNOVATION IN MOBILITY™

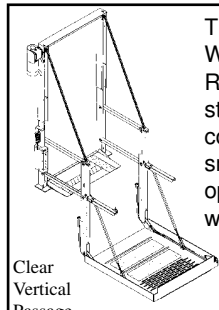

The **UNI-Lite™** Wheelchair Lift from Ricon is lightweight and strong, with its innovative controller it is one of the smoothest and quietest operating lifts in the world.

Clear Vertical Passage

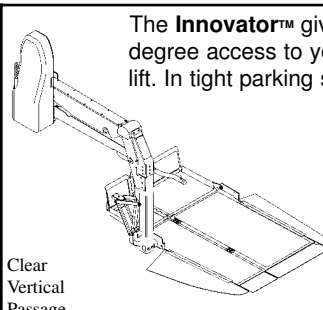

The **Innovator™** gives you 180-degree access to your wheelchair lift. In tight parking situations

Clear Vertical Passage

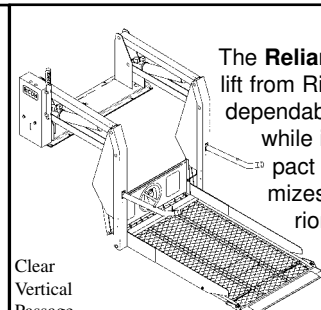

The **Reliant™** wheelchair lift from Ricon offers you dependable accessibility while its trim, compact design maximizes valuable interior space.

Clear Vertical Passage

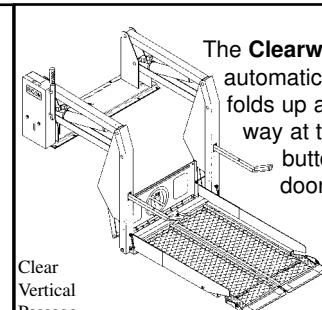

The **Clearway's™** fully automatic split platform folds up and out of the way at the push of a button, leaving the doorway clear.

Clear Vertical Passage

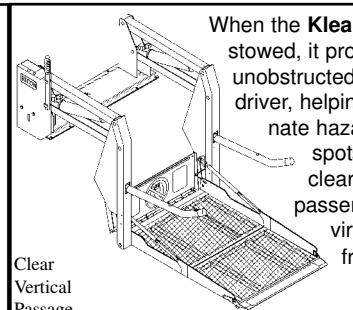

When the **KlearVue™** lift is stowed, it provides an unobstructed view for the driver, helping to eliminate hazardous blind spots, allows a clear view for the passengers, and is virtually unseen from outside.

Clear Vertical Passage

STANDARD FLOOR STANDARD ROOF & DOORS	SIDE SLIDE DOOR	up to 47"	U6-2636 (C) ^{16&b} U6-2639 (C) ^{16&b} U6-2940 ^{16&b}	up to 47"	SPL-1 ¹⁸		up to 47"	S1101 ¹⁰ S1200 ¹⁰ S1204 ¹⁰	up to 47"	S1132 ¹⁰ S1230 ¹⁰	S1133 ¹⁰ S1231 ¹⁰	up to 47"	K1200 ^{10&15} K1203 ^{10&15} K1205 ^{10&15}								
	SIDE SWING DOORS	up to 47"	U6-2636 (C) ^{16&b} U6-2639 (C) ^{16&b} U6-2940 ^{16&b}	up to 47"	SPL-1 ¹⁹		up to 47"	S1101 ^{11&15} S1200 ^{11&15} S1204 ^{11&15}	up to 47"	S1132 ^{11&15} S1230 ^{11&15}	S1133 ^{11&15} S1231 ^{11&15}	up to 47"	K1200 ^{11&15} K1203 ^{11&15} K1205 ^{11&15}								
	REAR SWING DOORS	up to 47"	U6-2636 (C) ^{16&b} U6-2639 (C) ^{16&b} U6-2940 ^{16&b}	up to 47"	N/A		up to 47"	S1101 ^{14&15} S1200 ^{14&15} S1204 ^{14&15}	up to 47"	S1132 ^{14&15} S1230 ^{14&15}	S1133 ^{14&15} S1231 ^{14&15}	up to 47"	K1200 ^{14&15} K1203 ^{14&15} K1205 ^{14&15}								
LOWERED FLOOR STANDARD ROOF & DOORS	SIDE SLIDE DOOR	up to 53"	U6-2644 ^{16&b} U6-2944 ^{16&b} U6-3240 ^{16&b} U6-3244 ^{16&b}	up to 57"	U6-2944 (T) ^{16&b} U6-3240 (T) ^{16&b} U6-3244 (T) ^{16&b}	up to 53"	SPL-1 ²¹	up to 57"	SPL-1 ²¹	up to 53"	S1207 ¹⁵ S1208 ¹⁵	up to 57"	S1203 ¹⁵ S1205 ¹⁵	up to 53"	S1132 ¹⁵ S1133 ¹⁵ S1230 ¹⁵ S1231 ¹⁵	up to 57"	S1132 ¹⁵ S1133 ¹⁵ S1230 ¹⁵ S1231 ¹⁵	up to 53"	K1200 ¹⁵ K1203 ¹⁵ K1205 ¹⁵	up to 57"	K1200 ¹⁵ K1203 ¹⁵ K1205 ¹⁵
	SIDE SWING DOORS	up to 53"	U6-2644 ^{16&b} U6-2944 ^{16&b} U6-3240 ^{16&b} U6-3244 ^{16&b}	up to 57"	U6-2944 (T) ^{16&b} U6-3240 (T) ^{16&b} U6-3244 (T) ^{16&b}	up to 53"	SPL-1 ²⁰	up to 57"	SPL-1 ²⁰	up to 53"	S1207 ¹⁵ S1208 ¹⁵	up to 57"	S1203 ¹⁵ S1205 ¹⁵	up to 53"	S1132 ¹⁵ S1133 ¹⁵ S1230 ¹⁵ S1231 ¹⁵	up to 57"	S1132 ¹⁵ S1133 ¹⁵ S1230 ¹⁵ S1231 ¹⁵	up to 53"	K1200 ¹⁵ K1203 ¹⁵ K1205 ¹⁵	up to 57"	K1200 ¹⁵ K1203 ¹⁵ K1205 ¹⁵
	REAR SWING DOORS	up to 53"	U6-2644 ^{16&b} U6-2944 ^{16&b} U6-3240 ^{16&b} U6-3244 ^{16&b}	up to 57"	U6-2944 (T) ^{16&b} U6-3240 (T) ^{16&b} U6-3244 (T) ^{16&b}	up to 53"	N/A	up to 57"	N/A	up to 53"	S1207 ¹⁵ S1208 ¹⁵	up to 57"	S1203 ¹⁵ S1205 ¹⁵	up to 53"	S1132 ¹⁵ S1133 ¹⁵ S1230 ¹⁵ S1231 ¹⁵	up to 57"	S1132 ¹⁵ S1133 ¹⁵ S1230 ¹⁵ S1231 ¹⁵	up to 53"	K1200 ¹⁵ K1203 ¹⁵ K1205 ¹⁵	up to 57"	K1200 ¹⁵ K1203 ¹⁵ K1205 ¹⁵
LOWERED FLOOR RAISED ROOF & DOORS	SIDE SLIDE DOOR	up to 53"	U6-2644 ^{16&b} U6-2944 ^{16&b} U6-3240 ^{16&b} U6-3244 ^{16&b}	up to 57"	U6-2944 (T) ^{16&b} U6-3240 (T) ^{16&b} U6-3244 (T) ^{16&b}	up to 53"	SPL-1 ^{21&a}	up to 57"	SPL-1 ^{21&a}	up to 53"	S1207 ¹⁵ S1208 ¹⁵	up to 57"	S1203 ¹⁵ S1205 ¹⁵	up to 53"	S1132 ¹⁵ S1133 ¹⁵ S1230 ¹⁵ S1231 ¹⁵	up to 57"	S1132 ¹⁵ S1133 ¹⁵ S1230 ¹⁵ S1231 ¹⁵	up to 53"	K1200 ¹⁵ K1203 ¹⁵ K1205 ¹⁵	up to 57"	K1200 ¹⁵ K1203 ¹⁵ K1205 ¹⁵
	SIDE SWING DOORS	up to 53"	U6-2644 ^{16&b} U6-2944 ^{16&b} U6-3240 ^{16&b} U6-3244 ^{16&b}	up to 57"	U6-2944 (T) ^{16&b} U6-3240 (T) ^{16&b} U6-3244 (T) ^{16&b}	up to 53"	SPL-1 ^{20&a}	up to 57"	SPL-1 ^{20&a}	up to 53"	S1207 ¹⁵ S1208 ¹⁵	up to 57"	S1203 ¹⁵ S1205 ¹⁵	up to 53"	S1132 ¹⁵ S1133 ¹⁵ S1230 ¹⁵ S1231 ¹⁵	up to 57"	S1132 ¹⁵ S1133 ¹⁵ S1230 ¹⁵ S1231 ¹⁵	up to 53"	K1200 ¹⁵ K1203 ¹⁵ K1205 ¹⁵	up to 57"	K1200 ¹⁵ K1203 ¹⁵ K1205 ¹⁵
	REAR SWING DOORS	up to 53"	U6-2644 ^{16&b} U6-2944 ^{16&b} U6-3240 ^{16&b} U6-3244 ^{16&b}	up to 57"	U6-2944 (T) ^{16&b} U6-3240 (T) ^{16&b} U6-3244 (T) ^{16&b}	up to 53"	N/A	up to 57"	N/A	up to 53"	S1207 ¹⁵ S1208 ¹⁵	up to 57"	S1203 ¹⁵ S1205 ¹⁵	up to 53"	S1132 ¹⁵ S1133 ¹⁵ S1230 ¹⁵ S1231 ¹⁵	up to 57"	S1132 ¹⁵ S1133 ¹⁵ S1230 ¹⁵ S1231 ¹⁵	up to 53"	K1200 ¹⁵ K1203 ¹⁵ K1205 ¹⁵	up to 57"	K1200 ¹⁵ K1203 ¹⁵ K1205 ¹⁵
STANDARD FLOOR RAISED ROOF & DOORS	SIDE SLIDE DOOR	up to 53"	U6-2644 ^{16&b} U6-2944 ^{16&b} U6-3240 ^{16&b} U6-3244 ^{16&b}	up to 57"	U6-2944 (T) ^{16&b} U6-3240 (T) ^{16&b} U6-3244 (T) ^{16&b}	up to 53"	SPL-1 ^{21&a}	up to 57"	SPL-1 ^{21&a}	up to 53"	S1207 ¹⁰ S1208 ¹⁰	up to 57"	S1203 ¹⁰ S1205 ¹⁰	up to 53"	S1132 ¹⁰ S1133 ¹⁰ S1230 ¹⁰ S1231 ¹⁰	up to 57"	S1132 ¹⁰ S1133 ¹⁰ S1230 ¹⁰ S1231 ¹⁰	up to 53"	K1200 ¹⁰ K1203 ¹⁰ K1205 ¹⁰	up to 57"	K1200 ¹⁰ K1203 ¹⁰ K1205 ¹⁰
	SIDE SWING DOORS	up to 53"	U6-2644 ^{16&b} U6-2944 ^{16&b} U6-3240 ^{16&b} U6-3244 ^{16&b}	up to 57"	U6-2944 (T) ^{16&b} U6-3240 (T) ^{16&b} U6-3244 (T) ^{16&b}	up to 53"	SPL-1 ^{20&a}	up to 57"	SPL-1 ^{20&a}	up to 53"	S1207 ¹¹ S1208 ¹¹	up to 57"	S1203 ¹¹ S1205 ¹¹	up to 53"	S1132 ¹¹ S1133 ¹¹ S1230 ¹¹ S1231 ¹¹	up to 57"	S1132 ¹¹ S1133 ¹¹ S1230 ¹¹ S1231 ¹¹	up to 53"	K1200 ¹¹ K1203 ¹¹ K1205 ¹¹	up to 57"	K1200 ¹¹ K1203 ¹¹ K1205 ¹¹
	REAR SWING DOORS	up to 53"	U6-2644 ^{16&b} U6-2944 ^{16&b} U6-3240 ^{16&b} U6-3244 ^{16&b}	up to 57"	U6-2944 (T) ^{16&b} U6-3240 (T) ^{16&b} U6-3244 (T) ^{16&b}	up to 53"	N/A	up to 57"	N/A	up to 53"	S1207 ¹⁴ S1208 ¹⁴	up to 57"	S1203 ¹⁴ S1205 ¹⁴	up to 53"	S1132 ¹⁴ S1133 ¹⁴ S1230 ¹⁴ S1231 ¹⁴	up to 57"	S1132 ¹⁴ S1133 ¹⁴ S1230 ¹⁴ S1231 ¹⁴	up to 53"	K1200 ¹⁵ K1203 ¹⁵ K1205 ¹⁵	up to 57"	K1200 ¹⁵ K1203 ¹⁵ K1205 ¹⁵
LOWERED FLOOR RAISED ROOF- STANDARD DOORS	SIDE SLIDE DOOR	up to 53"	U6-2644 ^{16&b} U6-2944 ^{16&b} U6-3240 ^{16&b} U6-3244 ^{16&b}	up to 57"	U6-2944 (T) ^{16&b} U6-3240 (T) ^{16&b} U6-3244 (T) ^{16&b}	up to 53"	SPL-1 ²¹	up to 57"	SPL-1 ²¹	up to 53"	S1207 ¹⁵ S1208 ¹⁵	up to 57"	S1203 ¹⁵ S1205 ¹⁵	up to 53"	S1132 ¹⁵ S1133 ¹⁵ S1230 ¹⁵ S1231 ¹⁵	up to 57"	S1132 ¹⁵ S1133 ¹⁵ S1230 ¹⁵ S1231 ¹⁵	up to 53"	K1200 ¹⁵ K1203 ¹⁵ K1205 ¹⁵	up to 57"	K1200 ¹⁵ K1203 ¹⁵ K1205 ¹⁵
	SIDE SWING DOORS	up to 53"	U6-2644 ^{16&b} U6-2944 ^{16&b} U6-3240 ^{16&b} U6-3244 ^{16&b}	up to 57"	U6-2944 (T) ^{16&b} U6-3240 (T) ^{16&b} U6-3244 (T) ^{16&b}	up to 53"	SPL-1 ²⁰	up to 57"	SPL-1 ²⁰	up to 53"	S1207 ¹⁵ S1208 ¹⁵	up to 57"	S1203 ¹⁵ S1205 ¹⁵	up to 53"	S1132 ¹⁵ S1133 ¹⁵ S1230 ¹⁵ S1231 ¹⁵	up to 57"	S1132 ¹⁵ S1133 ¹⁵ S1230 ¹⁵ S1231 ¹⁵	up to 53"	K1200 ¹⁵ K1203 ¹⁵ K1205 ¹⁵	up to 57"	K1200 ¹⁵ K1203 ¹⁵ K1205 ¹⁵
	REAR SWING DOORS	up to 53"	U6-2644 ^{16&b} U6-2944 ^{16&b} U6-3240 ^{16&b} U6-3244 ^{16&b}	up to 57"	U6-2944 (T) ^{16&b} U6-3240 (T) ^{16&b} U6-3244 (T) ^{16&b}	up to 53"	N/A	up to 57"	N/A	up to 53"	S1207 ¹⁵ S1208 ¹⁵	up to 57"	S1203 ¹⁵ S1205 ¹⁵	up to 53"	S1132 ¹⁵ S1133 ¹⁵ S1230 ¹⁵ S1231 ¹⁵	up to 57"	S1132 ¹⁵ S1133 ¹⁵ S1230 ¹⁵ S1231 ¹⁵	up to 53"	K1200 ¹⁵ K1203 ¹⁵ K1205 ¹⁵	up to 57"	K1200 ¹⁵ K1203 ¹⁵ K1205 ¹⁵
STANDARD FLOOR RAISED ROOF- STANDARD DOORS	SIDE SLIDE DOOR	up to 47"	U6-2636 (C) ^{16&b} U6-2639 (C) ^{16&b} U6-2940 ^{16&b}	up to 47"	SPL-1 ¹⁸		up to 47"	S1101 ¹⁵ S1200 ¹⁵ S1204 ¹⁵	up to 47"	S1132 ¹⁵ S1230 ¹⁵	S1133 ¹⁵ S1231 ¹⁵	up to 47"	K1200 ¹⁵ K1203 ¹⁵ K1205 ¹⁵								
	SIDE SWING DOORS	up to 47"	U6-2636 (C) ^{16&b} U6-2639 (C) ^{16&b} U6-2940 ^{16&b}	up to 47"	SPL-1 ¹⁹		up to 47"	S1101 ¹⁵ S1200 ¹⁵ S1204 ¹⁵	up to 47"	S1132 ¹⁵ S1230 ¹⁵	S1133 ¹⁵ S1231 ¹⁵	up to 47"	K1200 ¹⁵ K1203 ¹⁵ K1205 ¹⁵								
	REAR SWING DOORS	up to 47"	U6-2636 (C) ^{16&b} U6-2639 (C) ^{16&b} U6-2940 ^{16&b}	up to 47"	N/A		up to 47"	S1101 ¹⁵ S1200 ¹⁵ S1204 ¹⁵	up to 47"	S1132 ¹⁵ S1230 ¹⁵	S1133 ¹⁵ S1231 ¹⁵	up to 47"	K1200 ¹⁵ K1203 ¹⁵ K1205 ¹⁵								

APPLICATION CHART USER GUIDE

RICON LIFTS AND INSTALLATION KITS

Critical Dimensions For Specifying a Ricon Wheelchair Lift:

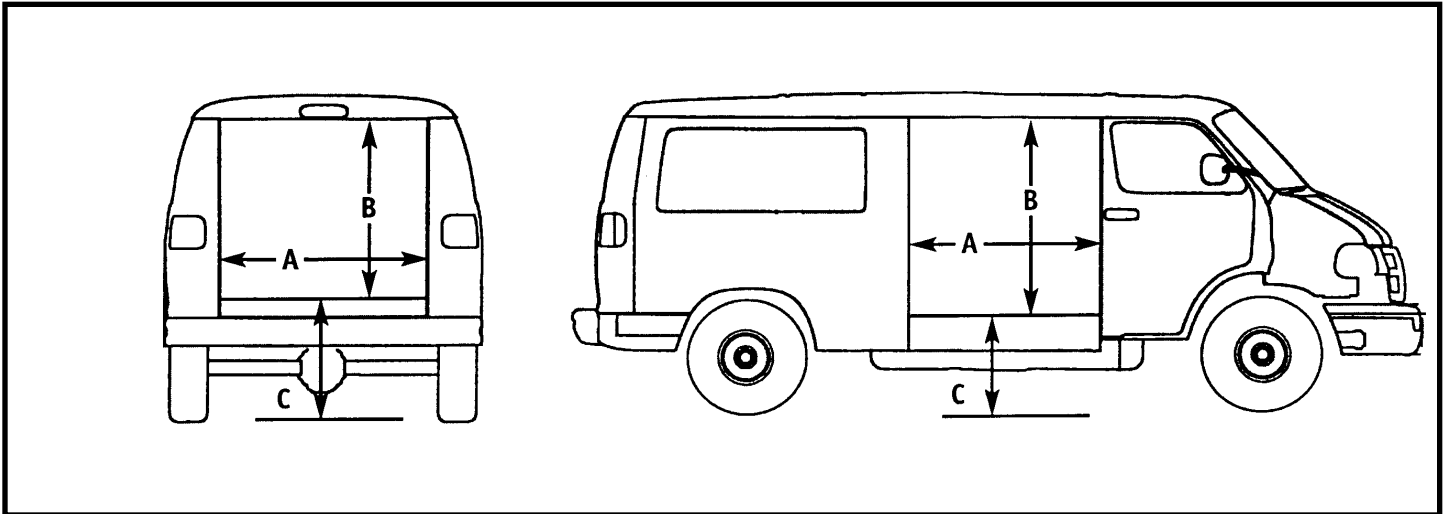

- _____ A) Clear Horizontal Passage
The finished (trimmed out) clear horizontal door opening width
- _____ B) Clear Vertical Passage
The finished clear vertical door opening height
- _____ C) Floor to Ground Travel
The maximum distance from the finished vehicle floor to the ground

Installation Kits: KlearVue, Clearway, UNI-lite, Reliant & Innovator*

1) 01152	2) 01170	3) 01215	4) 01197	5) 11100	6) 01156	7) 01195
8) 01181	9) 01160	10) 01210	11) 01207	12) 01161	13) 11200	14) 01171
15) 22601	16) 01172	17) 01081	18) 29926	19) 27902	20) 29967	21) 27990
21) 13440	23) 27976					

*See Application chart model number for corresponding lift/kit match

Notes:

- Additional modifications to the kit may be required
- Use installation kit #17 (01081) for units with rear air conditioning option
- Use installation kit #21 (13440) for units with rear air conditioning option
- Slim bumper configuration required

Ricon Corporation reserves the right to discontinue models or options at anytime or change specifications, materials, equipment, or pricing without notice and without incurring obligation.

RICON[®]

INNOVATION IN MOBILITY™

RACUG12/03 v.1 © 2003