

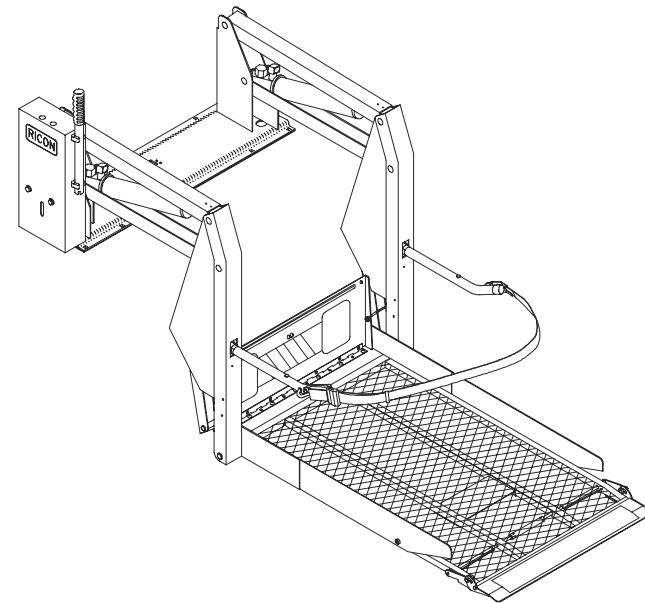

**Ricon**<sup>®</sup>

A **Wabtec** company

**S-Series<sup>®</sup>**  
**Transit Use (ADA)**  
**Wheelchair and Standee Lift**



**-PRINT-**  
**Operator Manual**

10/10/11

Printed in the United States of America

32DSS01.C

**-HOME-**

©2011 RICON CORPORATION

All Rights Reserved



U.S. Patent Nos: 5,228,538; 5,308,215; 5,373,915; 5,445,488; 5,605,431; 5,944,473

Australian Patent Nos: 661127; 687066

Canadian Patent No: 2,129,821

German Patent No: EP 0625896 B1

U.K. Patent No: EP 0625896 B1

Other U.S. and foreign patents pending.

**This RICON product must be installed and serviced by RICON dealers or qualified service technicians.**

**The operator must refer to this manual for operating instructions, then retain it for future reference by dealers or qualified service technicians who service this product.**

Customer Name: \_\_\_\_\_

Installing Dealer: \_\_\_\_\_

Date Installed: \_\_\_\_\_

Serial Number: \_\_\_\_\_

## REVISION RECORD

REV	PAGES	DESCRIPTION OF CHANGE	ECO
32dsss01. C	1-1	Update to registered trademark.	6560
	2-1	Update to Safety Precaution instructions.	
	2-1	Update to Figure 2-2 caption.	
	2-7	Update to Instruction 1.c, 1.d.	
	2-7	Update to Instruction 2.b, 2.c.	
	3-1	Update to registered trademark.	

**S-SERIES ADA TRANSIT TABLE OF CONTENTS**

<i>Chapter:</i>	<i>Page</i>
<b>I. INTRODUCTION</b> .....	<b>1-1</b>
A. RICON FIVE-YEAR LIMITED WARRANTY .....	1-2
B. SHIPMENT INFORMATION.....	1-3
C. GENERAL SAFETY PRECAUTIONS .....	1-3
D. MAJOR LIFT COMPONENTS .....	1-4
<b>II. OPERATING INSTRUCTIONS</b> .....	<b>2-1</b>
A. SAFETY PRECAUTIONS.....	2-1
B. DAILY SAFETY CHECK .....	2-2
C. LIFT FUNCTIONS .....	2-3
D. CONTROLS AND INDICATORS.....	2-4
• CONTROL PENDANT .....	2-4
• INTERLOCK INDICATOR LIGHT .....	2-4
• OPTIONAL DOOR OPERATOR CIRCUIT BREAKER .....	2-4
• CONTROL SYSTEM CIRCUIT BREAKER.....	2-4
• PUMP SOLENOID LED STATUS INDICATOR .....	2-5
• MAIN CIRCUIT BREAKER.....	2-5
• MANUAL BACK-UP PUMP .....	2-5
E. LIFT OPERATION.....	2-6
1. ENTERING VEHICLE .....	2-7
2. EXITING VEHICLE .....	2-7
3. STOWING PLATFORM .....	2-8
4. MANUAL OPERATION.....	2-8
<b>III. MAINTENANCE</b> .....	<b>3-1</b>
A. MAINTENANCE INFORMATION .....	3-1
B. CLEANING .....	3-1
C. MAINTENANCE .....	3-1
D. DECAL LOCATIONS.....	3-4

This page intentionally left blank.

**I. S-SERIES® TRANSIT USE (ADA) INTRODUCTION**

The RICON S-Series® Transit Use (ADA) Wheelchair and Standee Lift provides wheelchair access to transit vehicles. The patented movement provides smooth, safe entry and exit. The lift easily lifts up to 800 pounds (364 kilograms). It is operated by a trained attendant. The lift contains a powerful electro-hydraulic pump that includes a built-in manual backup pump. If the lift loses electrical power, it can still be raised and/or lowered manually.

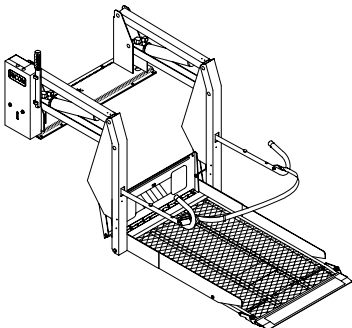

By using the lift control switches, the lift is unfolded out from the vehicle (deployed). The user boards the large non-skid platform and the operator uses the control switches to gently lower the platform to the ground. After the user departs, the platform is raised and folded into the vehicle (stowed).

This manual contains warranty information, safety precautions, operating instructions, and maintenance information for the lift. It is important to user safety that the lift operator be completely familiar with the Operating Instructions chapter of this manual. Once the lift is installed, it is very important that the lift be properly maintained by following the Ricon recommended maintenance and inspection instructions provided in **Chapter III**.

If there are questions about this manual, or additional copies are needed, please contact Ricon Product Support at one of the following locations:

**Ricon Corporation**  
**7900 Nelson Road**  
**Panorama City, Ca 91402 ..... (818) 267-3000**  
**Outside (818) Area Code ..... (800) 322-2884**  
**World Wide Website ..... www.riconcorp.com**

**Ricon U.K. Ltd.**  
**Littlemoss Business Park, Littlemoss Road**  
**Droylsden, Manchester**  
**United Kingdom, M43 7EF ..... (+44) 161 301 6000**

## A. RICON FIVE-YEAR LIMITED WARRANTY

### RICON CORPORATION FIVE-YEAR LIMITED WARRANTY

**Ricon Corporation (Ricon)** warrants to the original purchaser of this product that Ricon will repair or replace, at its option, any part that fails due to defective material or workmanship as follows:

- Repair or replace parts for a period of one year from the date of purchase.
- Labor costs for specified parts replace under this warranty for a period of one year from the date of purchase. A Ricon rate schedule determines the parts covered and labor allowed.
- Repair or replace lift power train parts for a period of five years from the date of purchase. A list of parts covered can be obtained from Ricon Product Support.

**If You Need to Return a Product:** Return this product to Ricon. Please give as much advance notice as possible, and allow a reasonable amount of time for repairs.

**This Warranty does not Cover:**

- Malfunction or damage to product parts caused by accident, misuse, lack of proper maintenance, neglect, improper adjustment, modification, alteration, the mechanical condition of the vehicle, road hazards, overloading, failure to follow operating instructions, or acts of Nature (i.e., weather, lightning, flood).

**Note:** Ricon recommends that this product be inspected by a Ricon dealer or qualified service technician at least once every six months, or sooner if necessary. Required maintenance should be performed at that time.



#### **WARNING!**

**THIS PRODUCT HAS BEEN DESIGNED AND MANUFACTURED TO EXACT SPECIFICATIONS. MODIFICATION OF THIS PRODUCT IN ANY RESPECT CAN BE DANGEROUS.**

**This Warranty is Void if:**

- The product has been installed or maintained by someone other than a Ricon dealer or qualified service technician.
- The product has been modified or altered in any respect from its original design without written authorization by Ricon.

**Ricon disclaims liability for any personal injury or property damage that results from operation of a Ricon product that has been modified from the original Ricon design. No person or company is authorized to change the design of this Ricon product without written authorization by Ricon.**

**Ricon's obligation under this warranty is exclusively limited to the repair or exchange of parts that fail within the applicable warranty period.**

**Ricon assumes no responsibility for expenses or damages, including incidental or consequential damages. Some states do not allow the exclusion or limitation of incidental or consequential damages, so the above limitation or exclusion may not apply.**

**Important: The warranty registration card must be completed and returned to Ricon within 20 days after installation of this Ricon product for the warranty to be valid. The warranty is not transferable.**

**The warranty gives specific legal rights, and there may be other rights that vary from state to state.**

## **B. SHIPMENT INFORMATION**

- When product is received, unpack it and check for freight damage. Claims for any damage should be made to freight carrier immediately.
- Be sure installation kit contains all items listed on kit packing list. Please report any missing items immediately to Ricon Product Support. The warranty and owner registration cards must be completed and returned to Ricon within 20 days for the warranty to be valid.

**NOTE:** The Sales/Service Personnel must review Warranty and Owner Manual with user to be certain that they understand safe operation of product. Instruct user to follow operating instructions without exception.

## **C. GENERAL SAFETY PRECAUTIONS**

The following general safety precautions must be followed during installation, operation, service and maintenance:

- Read and thoroughly understand operating instructions before attempting to operate.
- Inspect product before each use. If an unsafe condition, unusual noises or movements exist, do not use it until problem is corrected.
- Stand clear of doors and platform and keep others clear during operation.
- The product requires regular periodic maintenance. A thorough inspection is recommended at least once every six months. The product should be maintained at highest level of performance.



#### D. MAJOR LIFT COMPONENTS

The references used throughout this manual are illustrated in **Figure 1-1** and defined in **Table 1-1**. Refer to **Service Manual, Chapter IV, "Parts Diagrams and Lists"** for more details.

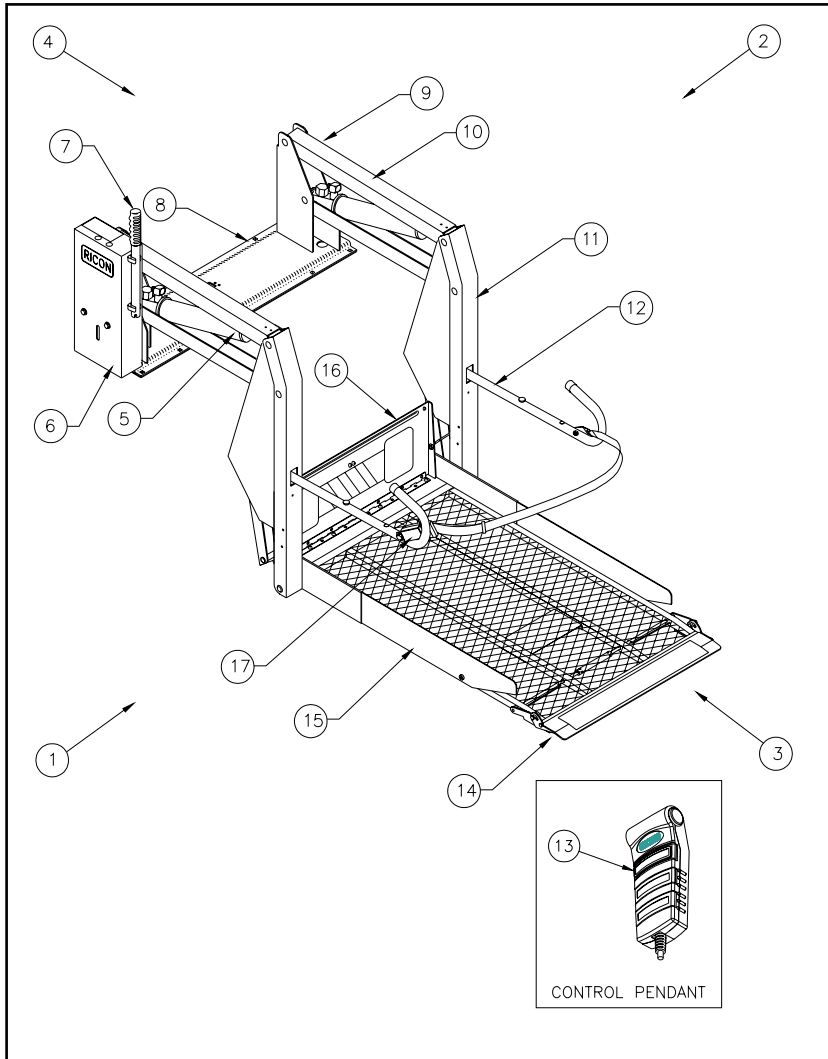

**FIGURE 1-1: TRANSIT USE (ADA) WHEELCHAIR AND STANDEE LIFT**

<b>TABLE 1-1: S-SERIES LIFT TERMINOLOGY</b>		
<b>REF</b>	<b>NAME</b>	<b>DESCRIPTION</b>
1	Left	Position references when lift is viewed from outside of vehicle.
2	Right	
3	Front	
4	Rear	
5	Hydraulic Cylinder	(Left and Right) Telescoping steel tube, which converts hydraulic pressure into lifting force.
6	Hydraulic Power Unit	Contains pump used to create hydraulic pressure to raise and fold lift, as well as a valve to unfold and lower lift.
7	Manual Backup Pump Handle	Used to operate manual back up-pump when electrical power is not functional.
8	Baseplate Assembly	Assembly that bolts securely to vehicle floor.
9	Serial Number Location	Location of serial number decal.
10	Top/Bottom Arms	(Left/Right) Upper and lower links connecting vertical arm to base assembly.
11	Vertical Arm	(Left/Right) Connects platform and top/bottom arms.
12	Handrail	(Left/Right) Provide hand-holds for platform occupant.
13	Control Pendant	Hand-held device used to control lift functions.
14	Front Rollstop	Front barrier prevents wheelchair from slow, inadvertent rolling off of platform during lift operation.
15	Platform	Component of lift where wheelchair and occupant sit during "Up" and "Down" operations.
16	Bridgeplate (Inboard Rollstop)	Barrier to prevent wheelchair from rolling off of platform during lift operation.
17	Occupant Restraint Belt	Electrically interlocked safety belt that is intended to prevent acceleration of wheelchair from platform. Lift will not operate unless belt is properly engaged.
<b>END OF TABLE</b>		

This page intentionally left blank.

## II. S-SERIES® ADA TRANSIT USE OPERATING INSTRUCTIONS

This chapter contains safety precautions, daily safety check instructions, control and indicator descriptions and operating instructions for the RICON S-Series® ADA Transit Use Wheelchair and Standee Lift. This chapter must be thoroughly understood before attempting to use the lift.

### A. SAFETY PRECAUTIONS

Comply with the following safety precautions when operating lift:

- Refer to **Figure 2-1**. Deploying platform when vehicle is on sloped ground is hazardous. Operate lift with vehicle parked on level ground.

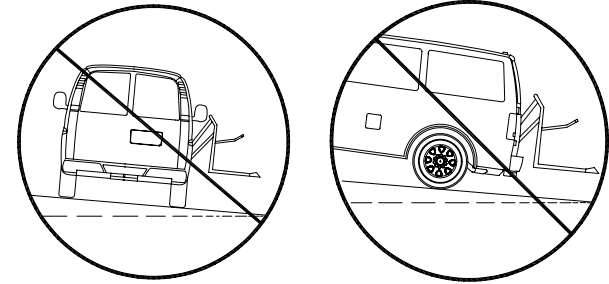

**FIGURE 2-1: DO NOT DEPLOY PLATFORM WHEN VEHICLE IS ON SLOPED GROUND**

- Vehicle must be safely parked with the emergency brake ON before using lift.
- Inspect lift prior to each use. DO NOT use if any unsafe condition exists or unusual noises or movements are noticed, and contact a Ricon dealer or qualified service technician for repair.
- Read and comply with all warning labels and symbols affixed to wheelchair lift.
- Refer to **Figure 2-2**. Due to variations in the size and configuration of mobility aids, for maximum safety, Ricon recommends that passengers always face outward when riding the lift platform.

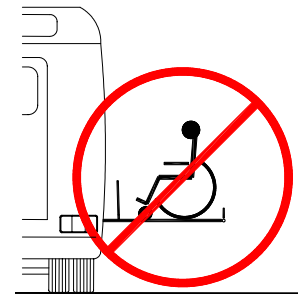

**FIGURE 2-2: RICON RECOMMENDS PASSENGERS FACE OUTBOARD WHEN RIDING LIFT PLATFORM**

- It is never safe for a wheelchair occupant to exit a vehicle facing inboard. It is not safe to rely on a threshold warning device (audible or other) to confirm that it is safe to exit vehicle while facing inboard. Exiting the vehicle while facing outboard allows for visual confirmation that the lift platform has been raised in the event that the threshold warning device is inoperative or unheard and prevents the occupant from exiting the vehicle backwards when the platform is still on the ground.
- When exiting vehicle, verify that platform is at same height as floor and front rollstop is up and locked.

- Do not place large equipment inside vehicle that can prevent pivoting of a wheelchair. Being able to pivot assures that a passenger can safely exit facing outward.
- The raised front rollstop prevents slow and unintentional rolling off of the platform. It is not intended to stop a fast-moving wheelchair, which might tip forward if the small front wheels collide with the rollstop.
- Be certain wheelchair fits safely on platform; it must not extend beyond edges or interfere with rising and locking of front rollstop.
- Do not operate with a load in excess of 800 lbs (364 kgs).
- Keep arms, legs, and clothing away from moving lift parts.
- The lift is intended for one wheelchair and its occupant or one standee. Do not overload lift.
- Refer to **Figure 2-3**. Do not stand in front of lift while deploying platform.



**FIGURE 2-3: STAND CLEAR OF PLATFORM**



- Keep others clear while operating lift.
- Do not allow an untrained person to operate lift.
- Careful supervision is necessary if used near children.
- Do not allow anyone to stand on bridgeplate. A bent bridgeplate can interfere with the platform as it rises and lowers.
- Lock wheelchair brakes when on platform (power chair users must turn off power and set brake).
- Use great care in wet conditions, because the wheelchair brakes are less effective if wheels or platform are wet.
- Never leave platform outside of vehicle. Return platform to stowed position after use.
- Do not load an oversize wheelchair into vehicle if it is too large to pivot freely inside vehicle.
- Read and understand these safety precautions. Review them periodically and ask other operators to read them as well. Contact a Ricon dealer or call Ricon Product Support if there are questions.

## **B. DAILY SAFETY CHECK**

Inspect the before each use and check that following conditions are met before operating:

- All functions operate properly. DO NOT use if unusual noises or movements exist, and contact a Ricon dealer or qualified service technician or Ricon Product Support for repair.
- Vehicle interlock is operating properly.
- No objects that may interfere with operation are present.
- General appearance and lubrication are satisfactory and all fasteners are tight.

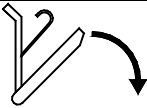
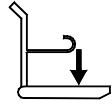
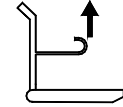
**C. LIFT FUNCTIONS**

TABLE 2-1: LIFT FUNCTIONS	
FUNCTION	DESCRIPTION
 <b>DEPLOY</b>	Platform unfolds/deploys out of vehicle from stowed position. (If equipped with a power door operator, the doors automatically open before lift deploys.)
 <b>DOWN</b>	Platform is lowered from vehicle floor level position to ground level. (The rollstop automatically lowers when platform reaches ground level.)
 <b>UP</b>	Platform is raised from ground level to vehicle floor level. (The rollstop automatically rises when platform leaves ground level.)
 <b>STOW</b>	Platform folds/stows from vehicle floor level to stowed position. (If equipped with a power door operator, the doors automatically close after lift stows.)
<b>END OF TABLE</b>	

**NOTE:** The up and down functions do not operate if platform is stowed.

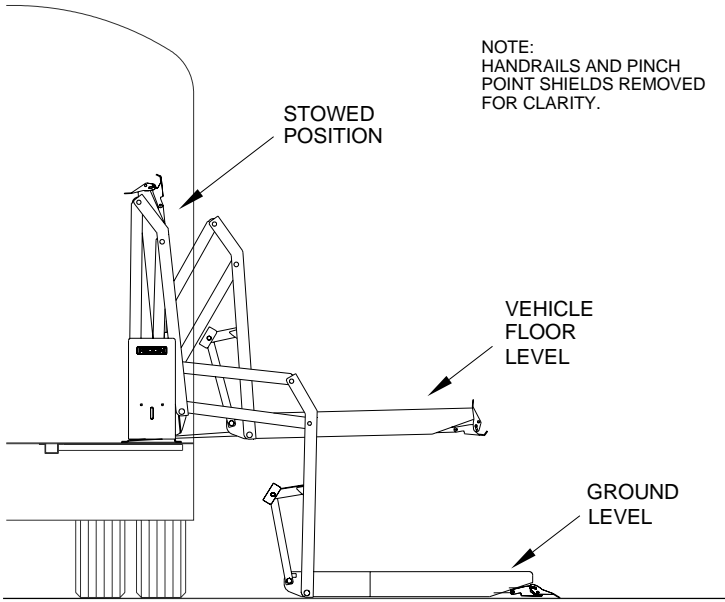

**FIGURE 2-4: PLATFORM POSITIONS**

## D. CONTROLS AND INDICATORS

### **WARNING**

THE LIFT CAN OPERATE ONLY WHEN VEHICLE MANUFACTURER INTERLOCK CIRCUITRY IS ACTIVATED. NEVER ATTEMPT TO OPERATE LIFT WITH INTERLOCK BYPASSED. REFER TO VEHICLE OWNER/OPERATOR MANUAL FOR INTERLOCK INSTRUCTIONS BEFORE OPERATING LIFT.

#### ■ Control Pendant

Refer to **Figure 2-5**. The lift is operated with two rocker buttons located on a hand-held, hard-wired remote-control pendant. Each lift function is controlled by pushing one end of the appropriate button. Pushing the DEPLOY button unfolds platform from vehicle, and pushing the STOW button folds platform into vehicle. Pushing the DOWN button lowers platform towards ground, and pushing the UP button raises platform towards floor. Buttons must be held depressed until function completes. The pendant is stowed on a wall-mounted clip inside vehicle.

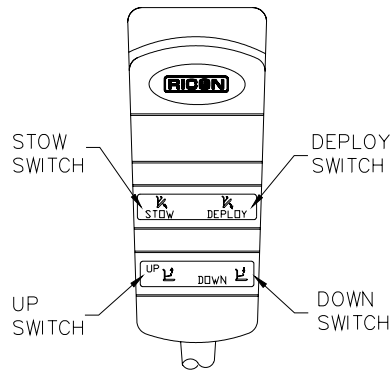

**FIGURE 2-5: CONTROL PENDANT**

#### ■ Interlock Indicator Light

Refer to **Figure 2-6** on following page. The purpose of a vehicle interlock system is to prevent operation of lift if an unsafe condition is present. When vehicle interlock systems are interfaced with lift circuitry, the interlock indicator shows whether or not interlock is operating properly. The light is interfaced with electrical system so that no matter which interlock system/method is used, the light will be ON when interlock allows electrical power to lift and OFF when interlock has disabled power to lift. When there is no interlock system installed, the light stays illuminated at all times.

#### ■ Optional Door Operator Circuit Breaker

Refer to **Figure 2-6** on following page. The circuit breaker for optional door operator is found on hydraulic pump assembly. In case of a door operator short circuit, the circuit breaker button will “pop-out”. If pressing and releasing button does not reset power, **DO NOT** press and hold. Contact a Ricon dealer or qualified service technician for repair. Refer to appropriate Ricon Remote Power Door Operator Service/Owner Manual for a detailed description.

#### ■ Control System Circuit Breaker

Refer to **Figure 2-6** on following page. The Control System Circuit Breaker is on hydraulic pump assembly. In case of a control system short circuit, circuit breaker button will “pop-out”. If pressing and releasing button does not reset power, **DO NOT** press and hold. Contact a Ricon dealer or qualified service technician for repair.

- Pump Solenoid LED Status Indicator

Refer to **Figure 2-6**. An LED is located between the 8A and 30A circuit breakers. The LED is normally green when the pump is operating and off when the pump is off. The LED also monitors the condition of the two pump solenoids. For more information on this LED refer to the service manual 32DSSS02.

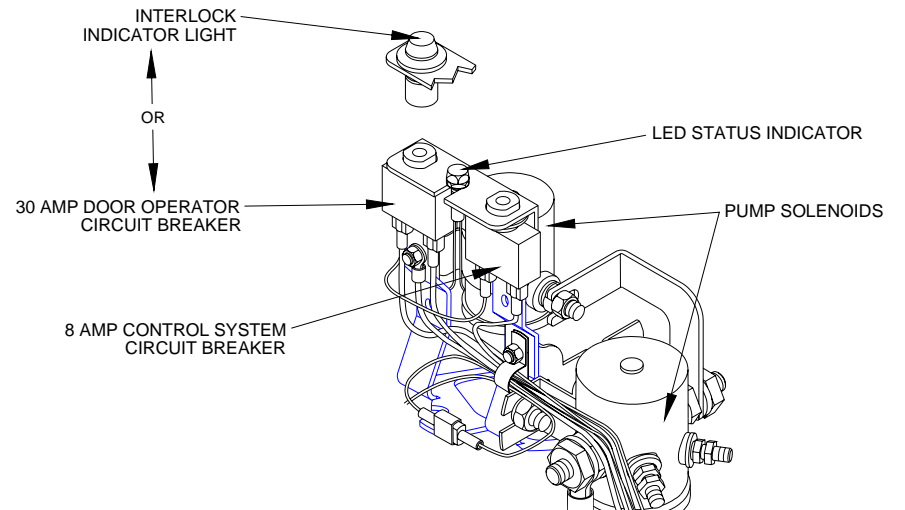

**FIGURE 2-6: INDICATOR LIGHT, CIRCUIT BREAKERS, AND LED INDICATOR**

- Main Circuit Breaker

Refer to **Figure 2-7**. The main circuit breaker is located in vehicle engine compartment and is designed to interrupt electrical power to lift electrical system when a short circuit occurs. In the event of a short circuit, the circuit breaker reset tab will “flip-down”. If pressing reset tab UP and releasing does not reset power, **DO NOT** press and hold tab. Contact a Ricon dealer or qualified service technician for repair.

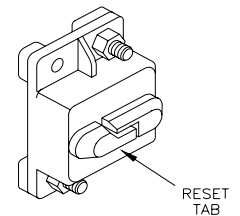

**FIGURE 2-7: MAIN CIRCUIT BREAKER**

- Manual Backup Pump

Refer to **Figure 2-8**. The manual backup pump is used to operate lift if electrical power is not functional. The controls for pump consist of a pump handle for raising lift platform and a pump release valve for lowering it. Instructions for operating manual pump are provided in the MANUAL OPERATION paragraph, which is part of the LIFT OPERATION section in this chapter.

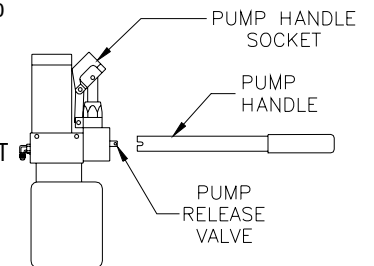

**FIGURE 2-8: MANUAL BACKUP PUMP & HANDLE**



## E. LIFT OPERATION

### WARNING

IMPROPER USE OF LIFT CAN RESULT IN PERSONAL INJURY. USERS MUST READ AND FOLLOW OPERATING INSTRUCTIONS IN OPERATOR MANUAL. ADDITIONAL COPIES OF OPERATOR MANUAL ARE AVAILABLE FROM:

RICON CORPORATION  
7900 NELSON ROAD  
PANORAMA CITY, CA 91402  
(800) 322-2884 or (818) 267-3000

DO NOT EXCEED RATED LOAD CAPACITY OF 800 POUNDS (364 KG).

PRIOR TO USE, INSPECT WHEELCHAIR LIFT FOR PROPER FUNCTION, REQUIRED MAINTENANCE, AND DAMAGE. IF A PROBLEM EXISTS, DO NOT USE LIFT, AND CONTACT A RICON DEALER OR QUALIFIED SERVICE TECHNICIAN FOR REPAIR.

THIS LIFT IS FOR USE BY WHEELCHAIR OCCUPANTS AND STANDEES, ONLY.

RICON CORPORATION DISCLAIMS LIABILITY FOR DAMAGE OR PERSONAL INJURY RESULTING FROM MODIFICATION TO LIFT, LACK OF MAINTENANCE OR REPAIR, NEGLIGENCE, ABUSE, OR FAILURE TO FOLLOW LIFT OPERATING INSTRUCTIONS.

- Before operating lift, be certain vehicle is safely parked on a level area away from traffic. Provide space for lift operation and passenger boarding.
- The lift operator must take special care to ensure that area is clear before deploying lift. Be certain there are no obstacles beneath platform.
- Open doors completely if lift is not equipped with a power door operator. If equipped with a power door operator, the vehicle doors automatically open before platform unfolds and deploys, and close after platform is folded and stowed.
- If so equipped, be certain that safety interlock mechanism (e.g. transmission, parking brake, etc.) is properly engaged before attempting to operate lift. The lift **will not** operate until this feature has been engaged properly.

### WARNING

ATTENDANT MUST REMAIN NEAR PASSENGER TO RENDER IMMEDIATE ASSISTANCE, IF NECESSARY. KEEP OTHERS CLEAR WHEN OPERATING LIFT. BE CERTAIN WHEELCHAIR FITS PROPERLY ON PLATFORM AND DOES NOT CONTACT ROLLSTOP, WHICH WOULD PREVENT IT FROM LOCKING WHEN PLATFORM RISES.

## 1. ENTERING VEHICLE

**NOTE:** The occupant restraint belt must be fastened to enable the DEPLOY, DOWN, and UP motions; the platform will not operate unless this safety mechanism is connected. Turn pendant power switch on.

- a. **DEPLOY PLATFORM** - Push and hold DEPLOY button until platform completely unfolds from vehicle and stops at floor level.
- b. **LOWER PLATFORM** - Push and hold DOWN button until lift contacts ground and rollstop opens completely.
- c. Unfasten occupant restraint belt, carefully place wheelchair in center of platform, facing outward (away from vehicle), and lock wheelchair brakes.



- ✘ A Standee must stand near the center of the platform, facing in the direction of travel (into vehicle), and firmly grasp handrails.
- d. Fasten occupant restraint belt. Insert belt tongue into buckle and listen for “click” then “tug” on belt tongue to confirm belt is securely fastened.
- e. **RAISE PLATFORM** - Push and hold UP button until platform rises and stops automatically at vehicle floor level.
- f. Release wheelchair brakes, carefully board passenger into vehicle, and secure wheelchair.
- g. Refer to “STOWING PLATFORM” section on next page and stow platform.

## 2. EXITING VEHICLE

**NOTE:** The occupant restraint belt must be fastened to enable the DEPLOY and DOWN motions. The platform will not operate unless this safety mechanism is connected.

- a. **DEPLOY PLATFORM** - Push and hold DEPLOY button until platform completely unfolds from vehicle and stops at vehicle floor level.



- b. Fasten occupant restraint belt. Insert belt tongue into buckle and listen for “click” then “tug” on belt tongue to confirm belt is securely fastened.
- c. Carefully place wheelchair in center of platform, facing outward (away from vehicle), and lock wheelchair brakes.



- ✘ A Standee must stand near the center of the platform, facing in the direction of travel (away from vehicle), and firmly grasp handrails.

- d. **LOWER PLATFORM** - Push and hold DOWN button until platform settles at ground level and front rollstop is fully lowered.
- e. Unfasten occupant restraint belt, release wheelchair brakes, and carefully assist passenger off platform.
- f. Refer to "STOWING PLATFORM" section and stow platform.

### 3. STOWING PLATFORM

**NOTE:** The occupant restraint belt **must** be fastened to enable the STOW/DEPLOY and UP/DOWN functions. The lift will not operate unless this safety mechanism is properly engaged.

- a. Push and hold STOW switch until platform folds completely into vehicle.

 <b>CAUTION</b>
Be certain platform has folded completely before attempting to close doors. To prevent damage to doors, do not release switch until platform has folded completely and lift pump motor has stopped automatically.

- b. Close vehicle doors if lift is not equipped with a power door operator. (If equipped with a power door operator, the vehicle doors automatically close after platform is folded and stowed).

### 4. MANUAL OPERATION

 <b>WARNING</b>
FOLLOW THE PRECAUTIONS AT BEGINNING OF "LIFT OPERATION" SECTION WHEN USING MANUAL BACKUP SYSTEM.

Refer to **Figure 2-9**. If lift electrical power is not functional, the lift can be operated manually as follows:

- Open doors completely. If equipped with a power door operator, refer to appropriate power door operator Owner Manual for manual operation instructions.

#### Deploy Platform

- 1) Override "Sto-Loc" feature by lifting inboard rollstop. This will separate "Sto-Loc" catch (attached to underside of inboard rollstop) from "Sto-Loc" latch (affixed to lift base assembly). If "Sto-Loc" is difficult to separate, use manual backup pump to raise lift slightly and thereby remove tension from catch; refer to "Stow Platform" paragraph in this section.
- 2) Insert notched end of pump handle into hole in hydraulic pump cover marked "RELEASE VALVE" and engage pump release valve.

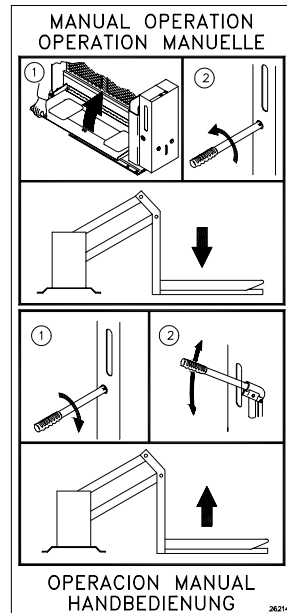

**FIGURE 2-9: MANUAL OPERATION**

 <b>CAUTION</b>
Do not open pump release valve more than <b>1/4-turn</b> . Opening valve further may cause it to disengage from pump body, which will disable pump.

- 3) Refer to **Figure 2-10**. Turn valve 1/4 turn COUNTER-CLOCKWISE to begin lowering platform. When platform reaches vehicle interior floor level turn valve CLOCKWISE to close; DO NOT OVER-TIGHTEN VALVE. Do not lower platform below vehicle floor level. The rear edge of inboard rollstop must rest flat against vehicle floor.

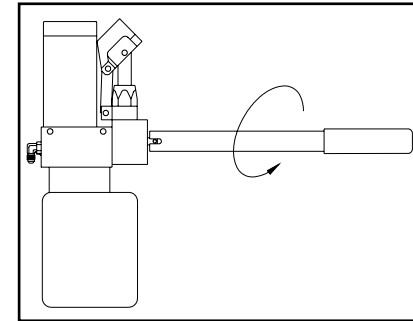

**FIGURE 2-10: DEPLOY OR LOWER PLATFORM**

#### **Lower Platform**

- 1) Turn valve 1/4 turn COUNTER-CLOCKWISE to begin lowering platform.
- 2) Hold valve OPEN until platform settles at ground level. Turn handle clockwise to CLOSE valve; DO NOT OVER-TIGHTEN VALVE

### Raise Platform

- 1) Refer to **Figure 2-11**. Check pump release valve to verify it is closed.

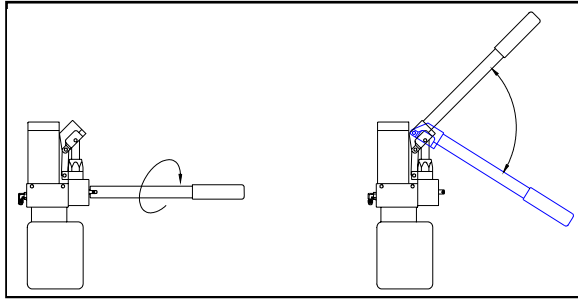

**FIGURE 2-11: MANUAL BACK-UP PUMP – RAISE PLATFORM**

- 2) Insert pump handle into pump handle socket. Operate pump to begin raising platform.
- 3) When platform reaches vehicle interior floor level turn valve **CLOCKWISE** to close; **DO NOT OVER-TIGHTEN VALVE**. Do not raise platform past vehicle floor level. The rear edge of inboard rollstop must rest flat against vehicle floor.

### Stow Platform

- 1) Refer to **Figure 2-11**. Check pump release valve to verify it is closed; **DO NOT OVER-TIGHTEN VALVE**.
- 2) Insert pump handle into pump handle socket. Operate pump to begin raising platform.
- 3) Operate pump until platform is **COMPLETELY** folded inside vehicle.
- 4) Stow pump handle. Close vehicle doors.

### III. S-SERIES® TRANSIT USE (ADA) MAINTENANCE

Regular maintenance of the RICON S-Series® (ADA) Transit Use Wheelchair and Standee Lift with Manual Rollstop is necessary to optimize its performance and reduce the need for repairs. This chapter contains cleaning instructions, a maintenance schedule, and a diagram showing decal locations and their part numbers.

#### A. ADDITIONAL MAINTENANCE INFORMATION

Additional maintenance information is available in the S-Series (ADA) Transit Use Service manual, part number 32DSS02. This manual is available from Ricon in printed hard copy, or at the Ricon website in PDF format. The website is located at [www.riconcorp.com](http://www.riconcorp.com). Click on RICON CORPORATION and then DEALER'S ROOM at the website. Entry to the dealer's room will require a Dealer Number and a Password.

 **CAUTION!**

THIS RICON PRODUCT IS HIGHLY SPECIALIZED. MAINTENANCE AND REPAIRS MUST BE PERFORMED BY A RICON DEALER OR QUALIFIED SERVICE TECHNICIAN USING RICON REPLACEMENT PARTS. MODIFYING OR FAILING TO PROPERLY MAINTAIN THIS PRODUCT WILL VOID WARRANTY AND MAY RESULT IN UNSAFE OPERATING CONDITIONS.

#### B. CLEANING

Regular cleaning with mild soap (i.e. dish soap, car wash liquid) and drying thoroughly will protect lift painted surfaces. Cleaning is especially important in areas where roads are salted in winter. Make sure that lift pivot points remain clear and clean prior to lubrication.

#### C. MAINTENANCE

Under normal operating conditions, maintenance inspections are required at least every six months (1750 cycles) and a thorough inspection should be performed at service intervals referenced in **Table 3-1**. Service should be increased under conditions of heavier use (more than 10 cycles per day).

<b>TABLE 3-1: MAINTENANCE SCHEDULE</b>	
<b>SERVICE POINT</b>	<b>ACTION TO PERFORM</b>
<b>DAILY SAFETY CHECK</b>	
Overall Condition	Listen for any abnormal noises as lift operates (i.e., grinding or binding noises).
Control Pendant	Check that control pendant is not damaged and cable connectors are tight.
<b>TWO-WEEK SAFETY CHECK</b>	
Overall Condition	Listen for any abnormal noises as lift operates (i.e., grinding or binding noises). Inspect underside of vehicle to be certain nothing is out of the ordinary.
Control Pendant	Check that control pendant is not damaged and cable connectors are tight.

**TABLE 3-1: MAINTENANCE SCHEDULE**

<b>SERVICE POINT</b>	<b>ACTION TO PERFORM</b>
Electrical Wiring	Inspect electrical wiring for frayed wires, chaffed wires, loose connectors, etc.
Vehicle Interlock	Place vehicle in NON-INTERLOCK mode and attempt to operate lift.
Decals	Be certain that all lift decals are affixed properly, clearly visible and legible. Replace if necessary.
Handrails	Be certain that all handrail fasteners are properly tightened.
Lift Mountings and Support Points	Be certain that all lift mounting and support points are in proper order and free from damage. Be certain that all mounting bolts are sufficiently tight.
Main Lifting Pivots	Be certain all traveling frame pins are installed properly, free from damage and locked in position.
Platform and Platform Attachment Points	Be certain platform operates properly during lift functions without obstruction(s).
Inner Rollstop	Be certain that inner rollstop operates properly during lift functions without obstruction(s). Be certain that inner rollstop deploys fully as platform stops at proper vehicle floor level.
Platform Rollstop	Be certain that rollstop operates properly without obstruction(s) when it contacts ground.
Hydraulic Power Unit	 <b>CAUTION</b> DO NOT ADD FLUID UNTIL PLATFORM IS LOWERED TO GROUND LEVEL. ADDING FLUID WHILE LIFT IS STOWED WILL CAUSE TANK TO OVERFLOW WHEN PLATFORM IS LOWERED.
	<ol style="list-style-type: none"> <li>1. Check for visible hydraulic fluid leakage.</li> <li>2. Be certain backup pump manual release valve is lightly-snug.</li> </ol>
<b>SIX-MONTH SAFETY CHECK (or @ 1750 cycles of operation)</b>	
Handrails	Be certain that all handrail fasteners are properly tightened.
Cleaning and Lubrication	Clean lift with a mild soap and wipe dry. Rub down all surfaces with a light oil using a soft cloth to avoid rusting of material. Wipe clean any excess oil. Following labeled directions on container, spray lubricant (Curtisol® Red Grease No.88167 or WD-40®), lubricate lift as specified in Lift Lubrication Points diagram. Wipe any excess grease from surrounding areas.
Hydraulic Power Unit	While platform is at GROUND LEVEL, be certain that pump hydraulic fluid level is maintained at required FULL level. Add only Texaco 01554 Aircraft Hydraulic Oil or equivalent U.S. mil spec H5606G fluid.

**CAUTION****THIS SAFETY CHECK PERFORMED BY A RICON DEALER.****ANNUAL SAFETY CHECK (or @ 3500 cycles of operation)**

Hydraulic Cylinder, Hoses and Fittings	Check Hydraulic Cylinder for evidence of leaks. Inspect hydraulic hoses for damage. Be certain that all fittings are tightly secured.
--	---

**END OF TABLE**



## D. DECAL LOCATIONS

Refer to **Figure 3-1**. Inspect decals at interval in **Table 3-1**. Inspect for chipping, peeling, fading, and illegibility. Order replacement decals by part number given in **Figure 3-1**, and apply where shown

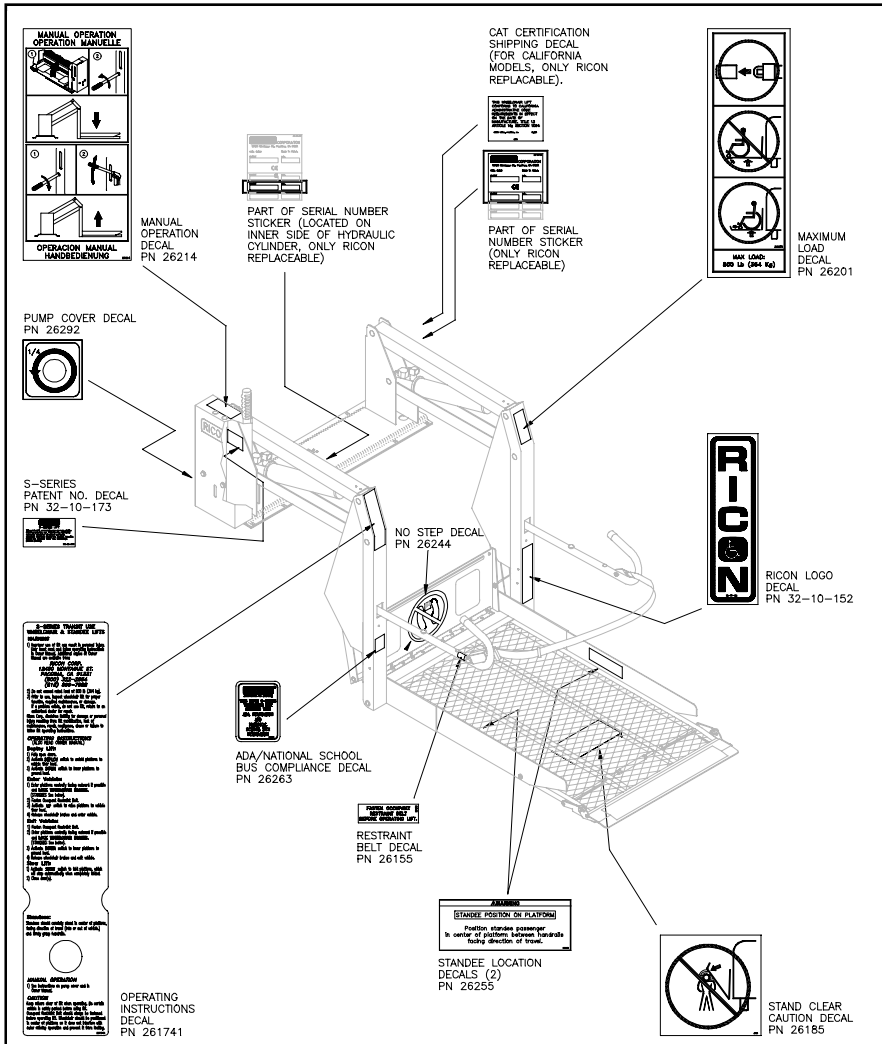

**FIGURE 3-1: DECAL LOCATIONS AND PART NUMBERS**