



Ricon®

A Wabtec company

S-Series™

Export Use

**Wheelchair and Standee Lift
with Folding Platform**

-Print-

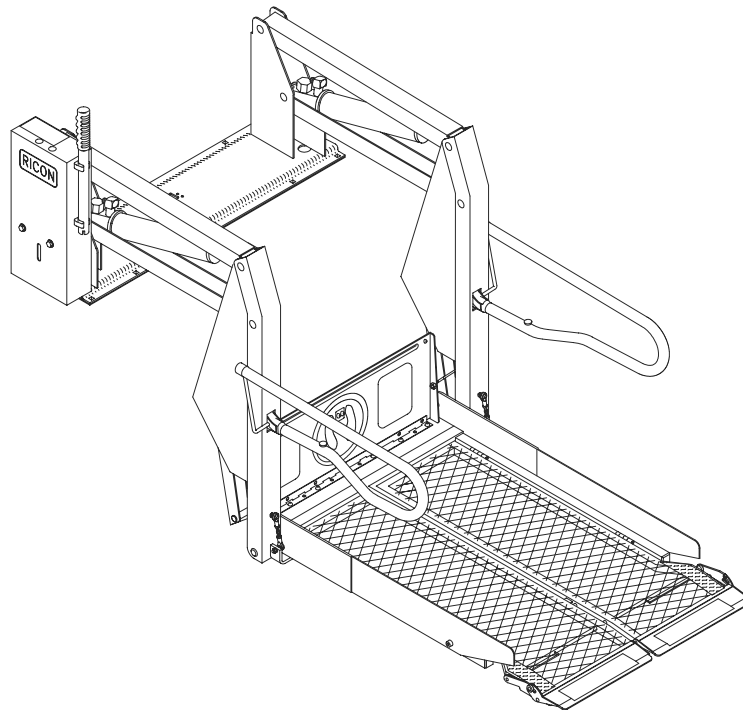

Service Manual

07/07/10

32DSSE02.D

©94-2010 RICON CORPORATION

U.S. Patent Nos: 4,534,450; 5,308,215; 5,445,488; 5,605,431; 5,944,473;

Australia Patent Nos: 687066;

Canadian Patent Nos: 1,245,603

Other U.S. and foreign patents pending

All Rights Reserved

Printed in the
United States of America

-Home-

This Ricon service manual is for use by qualified service technicians, and is not intended for use by non-professionals (do-it-yourselfers). The manual provides essential instructions and reference information, which supports qualified technicians in the correct installation and maintenance of Ricon products.

Qualified service technicians have the training and knowledge to perform maintenance work properly and safely. For the location of a qualified service technician in your area, call Ricon Product Support at 1-800-322-2884.

Customer Name: _____
Installing Dealer: _____
Date Installed: _____
Serial Number: _____

REVISION RECORD

REV	PAGES	DESCRIPTION OF CHANGE	ECR / ECO
32DSSE02. D	i	Updated text.	6560
	1-2	Updated text in warranty.	
	2-9	Updated figs 2-9, 10, 11, 13, 14, 15, & 16 to show double solenoid configuration.	
	2-18	Updated Platform Pressure Switch Check and Adjustment. Updated Figure 2-21.	
	2-18	Added Figures 2-23, 2-24.	
	2-19	Updated Figure 2-26.	
	3-1	Changed figure 3-1 to show lubrication of platform folding hinges.	
	3-5	Added Pump Solenoid LED Status Indicator section.	
	4-3	Updated Pump Parts List.	
	4-7	Updated Hydraulic Parts List.	
	4-9	Added item 8-8 (PM224100108).	
	4-9	Made changes to items 2, 4-3, 6, 17, 21, 32.	
	4-13	Made changes to items 4, 4-1, 5-1, -2, -3, -4, 7. Added items 7-12.	
	4-15	Made changes to items 4, 5, 19, 20, 23, 27, 29, 30, 33-1 & -2, 34.	
	4-17	Made changes to items 4-1, 5-1, 8, 10, 15, 16, 19-21, 23, 24, 26, 28-30, 32, 33-1, 34, 35, 43, 47, 49.	
	4-18	Made changes to item 57.	
	4-19	Made changes to items 1-1, 1-2, 1-3, 2-1, 2-3, 9, 16, 20-1 & -2, 21, 22-1, -2, -3, -4, 24, 25, 28.	
	4-20	Made changes to items 29, 32, 34, 36, 52-1, 56, 58, 59, 62, 80-82-2, 83-2, 85, 86-1 & -2, 87-1, 87-3, 89-1, 89-2, 90, 100, 104, 106.	
	4-23	Made changes to item 3.	
	4-4	Changed item 44 from 28494 to 32407.	
4-7	Changed item 31 from 25516 to 32408.		
4-15	Changed item 20 from 13307 to 34518.		
4-18	Changed item 106 from 14-30-410 to 34519.		
END OF LIST			

Chapter: *Page*

- I. INTRODUCTION..... 1-1**
 - RICON FIVE-YEAR LIMITED WARRANTY 1-2
 - A. SHIPMENT INFORMATION..... 1-3
 - B. GENERAL SAFETY PRECAUTIONS 1-3
 - C. MAJOR LIFT COMPONENTS..... 1-4
- II. INSTALLATION..... 2-1**
 - A. MECHANICAL INSTALLATION 2-1
 - 1. LIFT LOCATION..... 2-1
 - 2. LIFT INSTALLATION GUIDELINES 2-1
 - 3. LIFT INSTALLATION INTO VANS..... 2-2
 - 4. LIFT INSTALLATION INTO BUSES 2-4
 - B. ELECTRICAL INSTALLATION..... 2-5
 - 1. INSTALL MAIN CIRCUIT BREAKER..... 2-5
 - 2. ROUTE AND CONNECT MAIN POWER CABLE..... 2-6
 - 3. GROUND CONNECTIONS..... 2-8
 - 4. INSTALLATION OF UNSUPPORTED INTERLOCK DEVICES 2-9
 - C. FINAL ADJUSTMENTS..... 2-14
 - 1. LIMIT SWITCH ADJUSTMENT..... 2-14
 - 2. PLATFORM TILT ADJUSTMENT 2-16
 - 3. TIE ROD ASSEMBLY INSTALLATION AND ADJUSTMENT 2-16
 - 4. PLATFORM PRESSURE SWITCH CHECK AND ADJUSTMENT..... 2-18
 - 5. PLATFORM LOAD SENSOR SWITCH ADJUSTMENT 2-20
 - D. VERIFY INSTALLATION..... 2-20
 - E. CUSTOMER ORIENTATION 2-20
- III. MAINTENANCE AND REPAIR 3-1**
 - A. LUBRICATION 3-1
 - B. CLEANING 3-2
 - C. MAINTENANCE SCHEDULE..... 3-2
 - D. TROUBLESHOOTING 3-4
 - 1. INTERLOCK INDICATOR DIAGNOSTICS..... 3-4
 - 2. PUMP SOLENOID LED STATUS INDICATOR..... 3-5
 - 3. LIFT TROUBLESHOOTING..... 3-6
 - E. HYDRAULIC CIRCUIT DIAGRAM 3-7
 - F. ELECTRICAL WIRING DIAGRAMS..... 3-8
 - 1. DIAGRAM LEGEND..... 3-8
 - 2. LIMIT SWITCH STATES..... 3-9
 - 3. WIRING DIAGRAMS..... 3-10
- IV. PARTS DIAGRAMS AND LISTS..... 4-1**
- APPENDIX LIFT SPECIFICATIONS 4-22**

This page intentionally left blank.

I. S-SERIES EXPORT INTRODUCTION

The RICON S-Series Export Use Wheelchair and Standee Lift with Folding Platform provides wheelchair access to personal vans. The patented movement provides smooth, safe entry and exit and easily lifts up to 364 Kg (800 lbs.). It is operated by the wheelchair occupant or a trained attendant. The lift contains a powerful electro-hydraulic pump that includes a built-in manual backup pump. If lift loses electrical power, it can be raised or lowered manually.

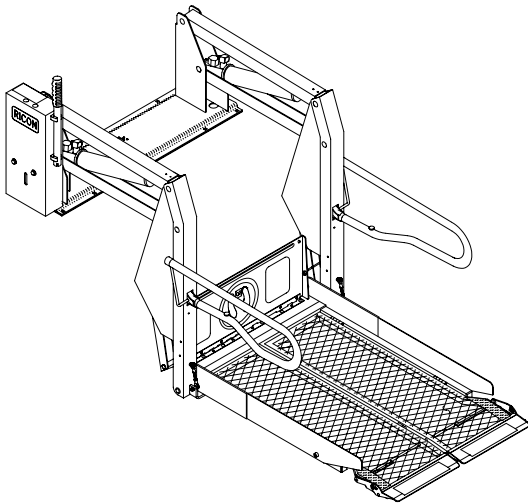

By using lift control switches, the lift is unfolded out from vehicle (deployed). The user boards the large non-skid platform and then uses the control switches to gently lower the platform to the ground. After the user departs, the platform is raised and folded into vehicle (stowed). The platform splits and folds when stowed, providing easy vehicle access through the lift.

This manual contains installation instructions; maintenance and repair instructions; troubleshooting guide; parts and diagram lists. It is important to user safety that lift operator(s) be completely familiar with the operating instructions. Once the lift is installed, it is very important that the lift be properly maintained by following the Ricon recommended cleaning, lubrication, and inspection instructions.

If there are questions about this manual, or additional copies are needed, please contact Ricon Product Support at one of the following locations:

Ricon Corporation
7900 Nelson Road
Panorama City, CA 91402.....(818) 267-3000
Outside (818) Area Code(800) 322-2884
World Wide Website..... www.riconcorp.com

Ricon U.K. Ltd.
Littlemoss Business Park, Littlemoss Road
Droylsden, Manchester
United Kingdom, M43 7EF.....(+44) 161 301 6000

RICON CORPORATION FIVE-YEAR LIMITED WARRANTY

Ricon Corporation (Ricon) warrants to original purchaser of this product that Ricon will repair or replace, at its option, any part that fails due to defective material or workmanship as follows:

- Repair or replace parts for a period of one year from date of purchase.
- Labor costs for specified parts replace under this warranty for a period of one year from date of purchase. A Ricon rate schedule determines the parts covered and labor allowed.
- Repair or replace lift power train parts for a period of five years from date of purchase. A list of parts covered can be obtained from your authorized Ricon dealer or Ricon Product Support.

If You Need to Return a Product: Return this Ricon product to your installing dealer. Please give advance notice, and allow a reasonable amount of time for repairs.

If You are Traveling: All Ricon authorized dealers honor this warranty. Consult telephone directory or call our Product Support department for the name of the nearest Ricon authorized dealer or qualified service technician.

This Warranty does not Cover:

- Malfunction or damage to product parts caused by accident, misuse, lack of proper maintenance, neglect, improper adjustment, modification, alteration, the mechanical condition of vehicle, road hazards, overloading, failure to follow operating instructions, or acts of nature (i.e., weather, lightning, flood).

Note: Ricon recommends that this product be inspected by a Ricon authorized dealer or qualified service technician at least once every six months, or sooner if necessary. Any required maintenance should be performed at that time.



WARNING

**THIS PRODUCT HAS BEEN DESIGNED AND MANUFACTURED TO EXACT SPECIFICATIONS.
MODIFICATION OF THIS PRODUCT IN ANY RESPECT CAN BE DANGEROUS.**

This Warranty is Void if:

- The product has been installed or maintained by someone other than a Ricon dealer or qualified service technician.
- The product has been modified or altered in any respect from its original design without written authorization by Ricon.

Ricon disclaims liability for any personal injury or property damage that results from operation of a Ricon product that has been modified from the original Ricon design. No person or company is authorized to change the design of this Ricon product without written authorization by Ricon.

Ricon's obligation under this warranty is exclusively limited to the repair or exchange of parts that fail within the applicable warranty period.

Ricon assumes no responsibility for expenses or damages, including incidental or consequential damages. Some states do not allow the exclusion or limitation of incidental or consequential damages, so the above limitation or exclusion may not apply.

Important: The warranty registration card must be completed and returned to Ricon within 20 days after installation of this Ricon product for the warranty to be valid. The warranty is not transferable. The warranty gives specific legal rights, and there may be other rights that vary from state to state.

A. SHIPMENT INFORMATION

Because of the specialized nature of this product, Ricon does not sell directly to user. Instead, the product is distributed through a worldwide network of authorized Ricon dealers, who perform actual installation.

- When the product is received, unpack it and check for freight damage. Claims for damage should be made to freight carrier immediately.
- Be sure installation kit contains all items listed on kit packing list. **Please report any missing items immediately to Ricon Product Support.** The warranty and owner registration cards must be completed and returned to Ricon within 20 days for the warranty to be valid.

NOTE: The Sales/Service Personnel must review Warranty and Operator manual with user. Verify that user understands safe operation of product, and instruct to follow operating instructions without exception.

B. GENERAL SAFETY PRECAUTIONS

The following general safety precautions must be followed during installation, operation, service, and maintenance:

- Under no circumstances should installation, maintenance, repair, and adjustments be attempted without immediate presence of a person capable of rendering aid.
- An injury, no matter how slight, should always be attended. Always administer first aid or seek medical attention immediately.
- Protective eyeshields and appropriate clothing should be worn at all times.
- To avoid injury, always exercise caution when operating and be certain that hands, feet, legs, and clothing are not in the path of product movement.
- Batteries contain acid that can burn. If acid comes in contact with skin, flush affected area with water and wash with soap immediately.
- Always work in a properly ventilated area. Do not smoke or use an open flame near a battery.
- Do not lay anything on top of a battery.
- Check under vehicle before drilling so as not to drill into frame, subframe members, wiring, hydraulic lines, fuel lines, fuel tank, etc.
- Read and thoroughly understand operating instructions before attempting to operate.
- Inspect product before each use. If an unsafe condition, unusual noises or movements exist, do not use it until problem is corrected.
- Never load or stand on platform until installation is complete. Upon completion of installation, always test load the lift to 125% of its rated load capacity.
- Stand clear of doors and platform and keep others clear during operation.
- The product requires regular periodic maintenance. A thorough inspection is recommended at least once every six months. The product must always be maintained at the highest level of performance.

C. MAJOR LIFT COMPONENTS

The references used throughout this manual are illustrated in **Figure 1-1** and defined in **Table 1-1**. Refer to **Chapter IV** for more details.

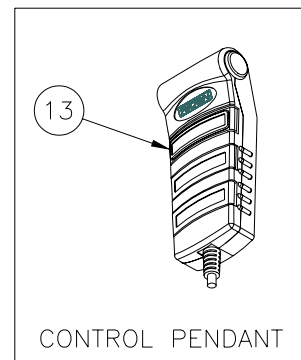
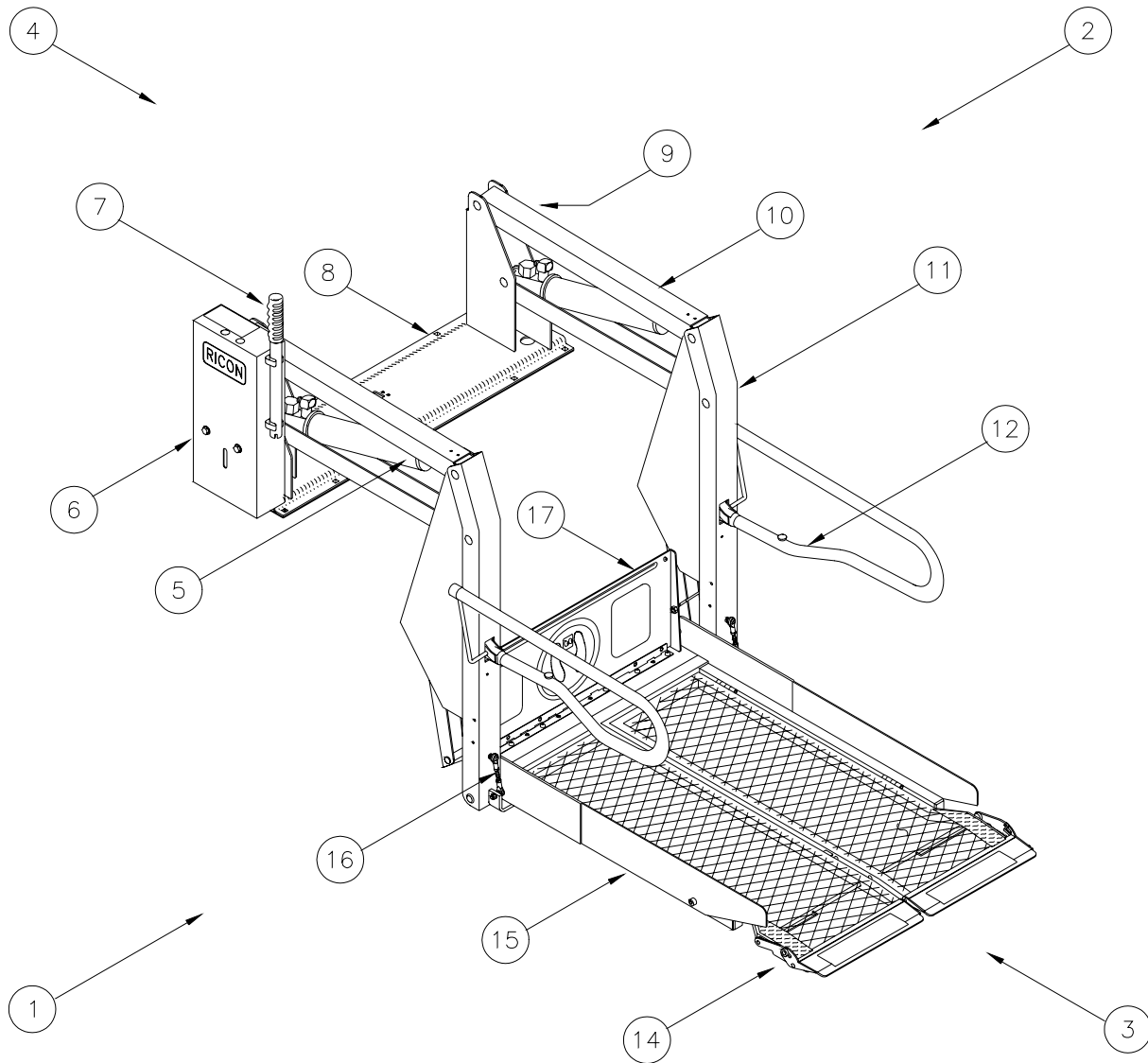

FIGURE 1-1: EXPORT USE WHEELCHAIR AND STANDEE LIFT

TABLE 1-1: S-SERIES EXPORT LIFT TERMINOLOGY		
REF	NAME	DESCRIPTION
1	Left	Lift references when installation is viewed from outside of vehicle.
2	Right	
3	Front	
4	Rear	
5	Hydraulic cylinders (left and right)	Telescoping cylinders convert hydraulic pressure into platform lifting force.
6	Hydraulic power unit	Contains electric motor driven pump that produces hydraulic pressure to raise and fold lift, and a pressure release valve to unfold and lower it.
7	Manual backup pump handle	Used to operate manual back up-pump when electrical power is not functional.
8	Baseplate assembly	Assembly that bolts securely to vehicle floor.
9	Serial number	Location of lift serial number decal.
10	Top and bottom arms (left and right)	Upper and lower parallel links connect vertical arms to base assembly.
11	Vertical arms (left and right)	Connects platform to top and bottom arms.
12	Handrails (left and right)	Provide a hand-hold for platform occupant.
13	Control pendant	Hand-held device used to control lift operating functions.
14	Platform rollstop	Front barrier prevents wheelchair from slowly or inadvertently rolling off of platform during lift operation.
15	Platform	Area of lift where wheelchair and occupant are situated during "Up" and "Down" motions.
16	Tie-Rods	(Left/Right) Mechanical links that cause platform to fold as it is stowed.
17	Bridgeplate (inboard rollstop)	Plate that bridges gap between platform and vehicle when platform is at floor height. Acts as barrier to confine wheelchair to platform during "Up" and "Down" motions.
END OF TABLE		

This page intentionally left blank.

II. EXPORT INSTALLATION

This chapter contains instructions for installing the RICON S-Series Export Use Wheelchair Lift with Folding Platform into most vans and buses, although custom installations are also possible in other types of vehicles. Due to the wide range of applications for lift, specific information for every possible application is not available. The following general procedures will apply to most installations. Contact the Ricon Product Support department for instruction about installations not covered. To install lift, refer to following sections and perform procedures carefully and in the order that they are presented. Be certain that installation instructions are followed exactly and do not eliminate any steps or modify product.

A. MECHANICAL INSTALLATION

1. LIFT LOCATION

The installation surface must be flat and level. It is recommended that lift be installed on a 1/2", minimum, high grade plywood sub-floor. However, this additional installation height may not be acceptable in cases where overhead clearance is limited.

NOTE: Check for proper travel clearance through doorway.

- a. With doors fully open, place/position lift in vehicle doorway as close as possible to door, with lift's baseplate assembly parallel to side of vehicle.
- b. Allow a distance of 3/4", if possible, between door and the part of lift closest to it. Adjust lift left and right side locations to accommodate subframe members.
- c. Verify proper clearance of door frame, passenger seats, and outer edge of vehicle floor and possible interference with wires, fluid lines, subframe members, etc.

2. LIFT INSTALLATION GUIDELINES

The mounting of lift is a very important step. Lift performance can be adversely affected by improper mounting or fastening of lift. Although fastening details may vary from one vehicle to the next, some general principles apply:

- ◆ Be certain that all mounting bolts are properly installed and tightened. Bolts used to fasten baseplate assembly to vehicle floor must have a minimum strength rating of SAE Grade 5 and be torqued to 28 ft lbs, dry. Recognize that the most important bolts are those along the rear of lift, since these bolts retain majority of load.
- ◆ Refer to **Figure 2-1**. Improper torquing sequence of bolts may result in a warped or bowed baseplate, which can cause lift to operate erratically.

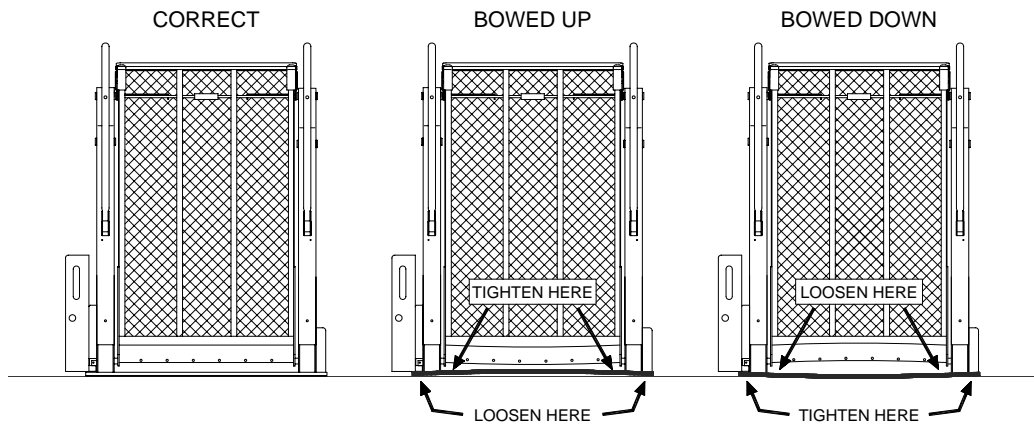

FIGURE 2-1: LIFT MOUNTING EXAMPLES

- ◆ Refer to **Figure 2-2**. On Ford van installations, clamping bars must be used to help evenly distribute floor loading and should only be cut if needed to clear a subframe member. A subframe member should be used to support clamping bar.

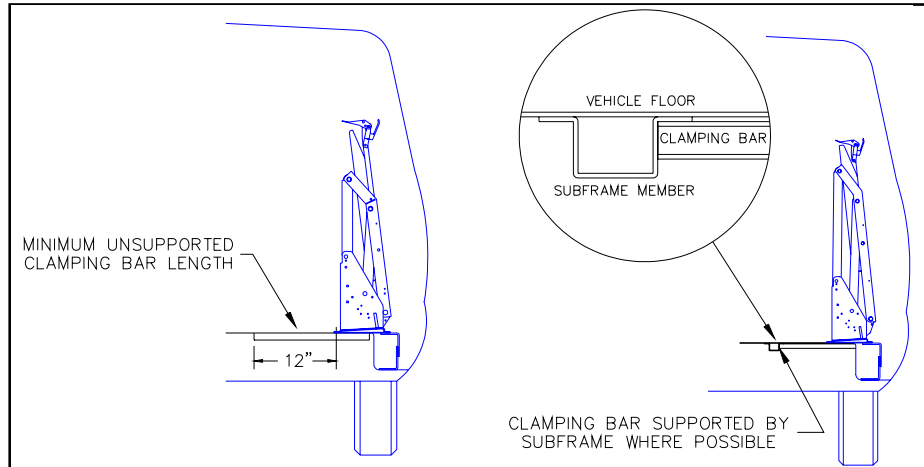

FIGURE 2-2: FORD VAN CLAMPING BAR ARRANGEMENT

3. LIFT INSTALLATION INTO VANS

- a. Refer to **Figure 2-3**. Use four 1" x 3/8" bolts, 3/8" washers, 3/8" lock washers, and 3/8" hex nuts to assemble two bracket assembly kits.

NOTE: The top bracket must overlap bottom bracket, and both slots must face outward.

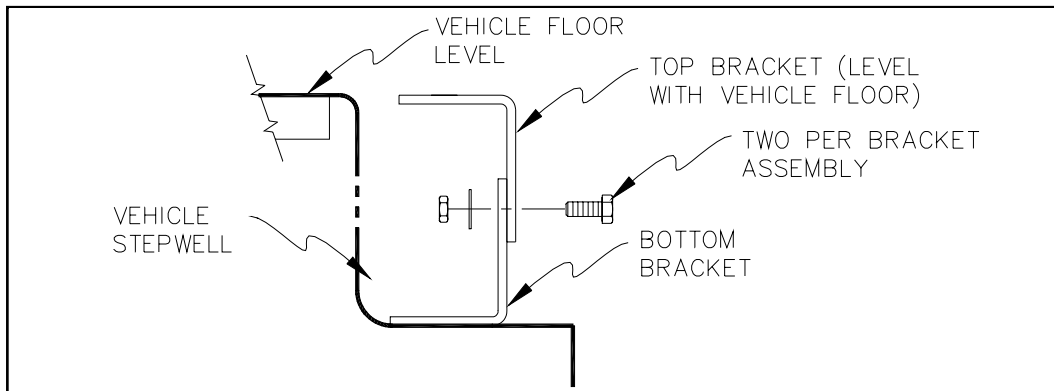

FIGURE 2-3: STEPWELL BRACKET

- b. Position and adjust height of both bracket assemblies so that top bracket is level with vehicle floor. Tighten bracket assembly bolts.
- c. Verify that lift is fully folded with handrails folded tight against vertical arms. If necessary, use manual pump.

⚠ WARNING

LIFT WEIGHT IS APPROXIMATELY 350 - 375 LBS. TAKE EXTREME CARE WHEN POSITIONING BECAUSE STEPWELL BRACKETS MAY TIP. THIS PROCEDURE MUST NOT BE ATTEMPTED BY ONE PERSON.

- d. Refer to **Figure 2-4**. With doors fully open, position lift in vehicle doorway so that back is supported by vehicle floor and front is supported by both bracket assemblies.

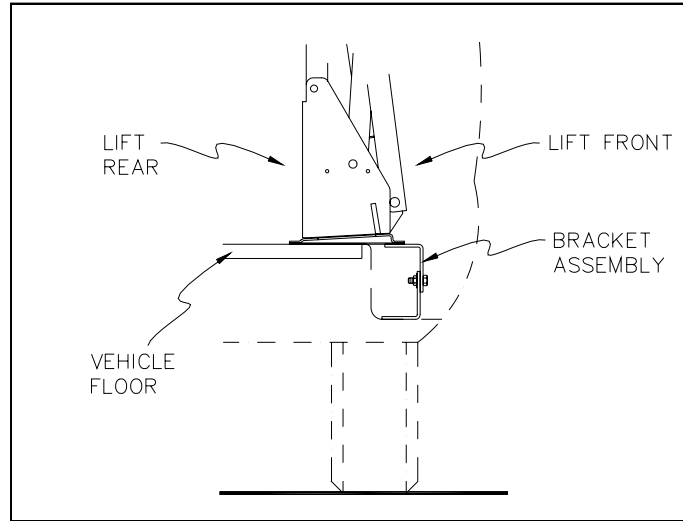

FIGURE 2-4: BRACKET ASSEMBLY

- e. Adjust Base Assembly:

NOTE: If Ricon power door operators are used, install them first. They may have some influence on location of lift.

- 1) Be certain baseplate assembly is parallel with vehicle floor. The baseplate assembly may be slightly offset in door opening to provide proper clearance for passenger seats.
- 2) Before drilling, be certain that lift position does not interfere with closing of vehicle doors or operation of passenger seats.

- f. Mark and Drill Holes:

NOTE: Before drilling any holes, be sure that no underlying wires or tubes are in the way.

- 1) Refer to **Figure 2-5**. Mark and drill four 25/64" baseplate assembly mounting holes (1, 2, 3, and 4) through vehicle floor. (On Dodge and GM vans, you must drill through vehicle floor and subframe).
- 2) Place four 8" x 3/8" carriage bolts (4" x 3/8" bolts on Ford vans) into holes to secure position.

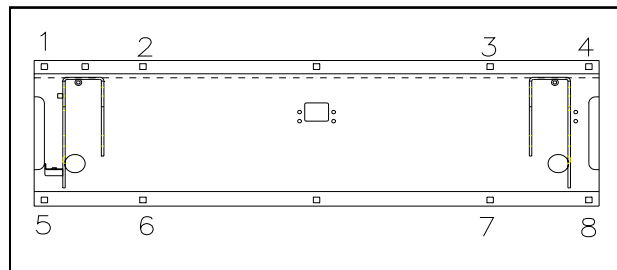

FIGURE 2-5: VAN BASEPLATE HOLES

- 3) Refer to **Figure 2-6** on following page. Match and align both top bracket holes 5, 6, 7 and 8 with baseplate assembly holes 5, 6, 7, and 8. Mark bracket assembly mounting holes 9, 10, 11, and 12 onto vehicle step.
- 4) Remove carriage bolts installed in step 2). Carefully push lift into vehicle interior.
- 5) Drill 1/4" dia holes through marked locations 9, 10, 11, and 12.

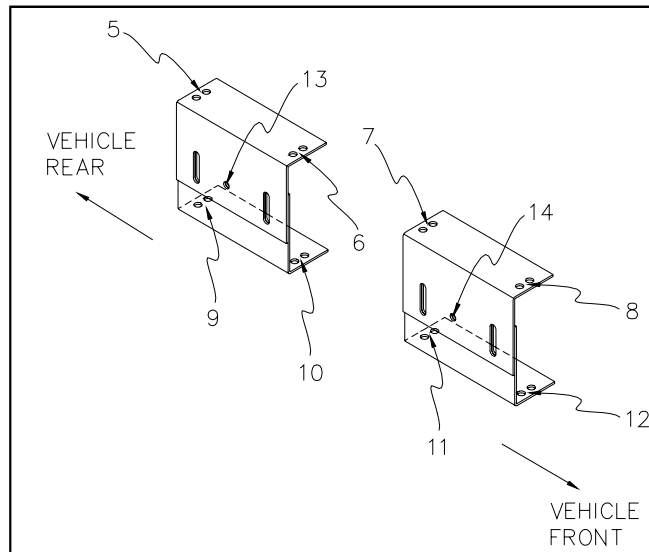

FIGURE 2-6: TOP BRACKET HOLE LOCATIONS

g. Fasten Bracket Assemblies and Lift:

- 1) Use 1-1/2" x 5/16" sheet metal screws with 5/16" lock washers to secure lower brackets to vehicle step holes 9 through 12.

NOTE: If screw in position 12 interferes with proper door operation, do not install.

- 2) Reposition lift and verify that surface beneath lift is free of obstacles.
- 3) Insert four 8" x 3/8" carriage bolts through mounting holes at rear of baseplate assembly, and insert four 1-1/2" x 3/8" carriage bolts through baseplate and bracket assemblies. Place 3/8" washers, lock washers, and nuts under bracket assemblies, and finger tighten nuts.

NOTE: On Dodge and GM vans, place four 4" x 4" plates, 3/8" washers, lock washers and hex nuts on 8" x 3/8" carriage bolts under van and finger tighten. On Ford models, reinforce vehicle floor with clamping bars. They are to be bolted in positions 1, 2, 3, and 4 and run across width of baseplate towards center of van.

- 4) Before tightening carriage bolts, verify that lift is level with vehicle floor. Adjust bracket assembly bolts if necessary.
- 5) Tilting lift towards inside of van may hinder its initial unfolding. Install lift with its baseplate assembly as level as possible. Tightening carriage bolts requires special care to keep baseplate assembly from warping when secured to vehicle floor. If baseplate assembly warps, the vertical arms will not be parallel. Corrections can be made by shimming at appropriate locations. To help prevent warping, tighten the eight carriage bolts (six on Dodge van with sliding door) to 28 ft. lbs. in the following sequence:

DODGE WITH SWING DOORS, ALL FORD AND GM VANS: **2, 3, 6, 7, 1, 4, 5, 8**

DODGE WITH SLIDING DOORS: **2, 3, 5, 8, 1, 4**

NOTE: Vertical arms must be parallel for proper operation. Adjust bolts as required. Best results are obtained when lift is mounted on plywood. Shims, although best avoided, may be used if required.

- 6) Make certain that holes 13 and 14 on front of each bracket assembly are drilled through and 5/16" bolts are inserted to lock position of bracket assemblies.

4. LIFT INSTALLATION INTO BUSES

! WARNING

THE S-SERIES EXPORT USE WHEELCHAIR LIFT MUST NOT BE INSTALLED INTO MASS TRANSIT VEHICLES. CONTACT RICON PRODUCT SUPPORT FOR PROPER S-SERIES LIFT.

Refer to **Figure 2-7**. Since clamping bars are used on most bus installations, they help distribute floor loading and should only be cut if needed to clear a subframe member. A subframe member should be used to support clamping bar.

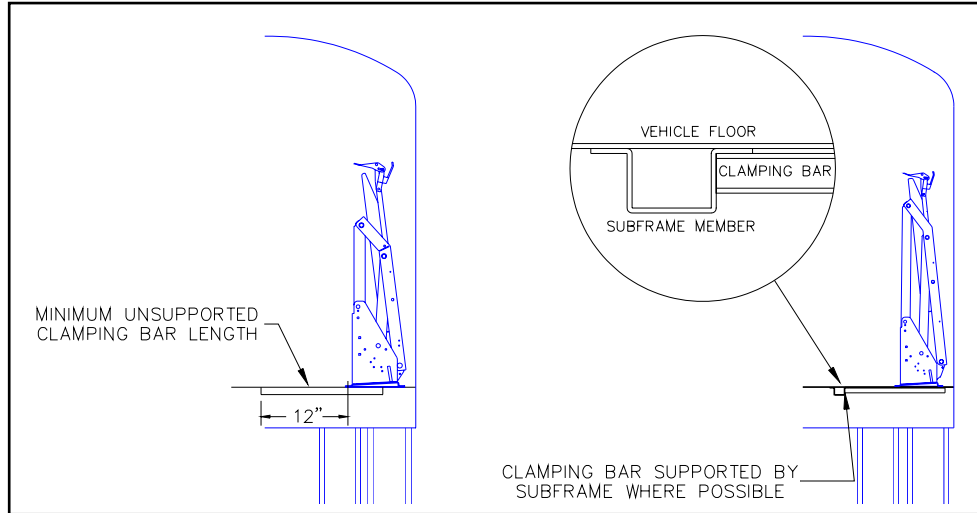

FIGURE 2-7: BUS CLAMPING BAR ARRANGEMENT

! WARNING

LIFT WEIGHT IS APPROXIMATELY 350-375 LBS. TAKE EXTREME CARE WHEN POSITIONING BECAUSE STEPWELL BRACKETS MAY TIP. THIS PROCEDURE SHOULD NOT BE ATTEMPTED BY ONE PERSON.

- a. With doors fully open, position lift in vehicle doorway as close as possible to door with lift baseplate parallel to side of bus.
- b. Refer to **Figure 2-8**. Mark and drill eight 25/64" baseplate assembly mounting holes (1 thru 8) through vehicle floor.

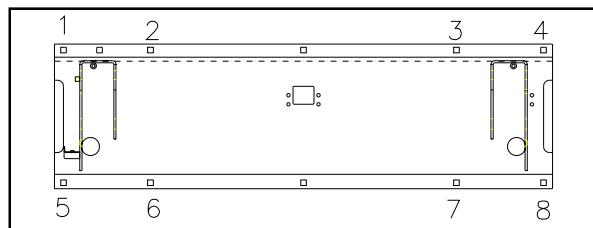

FIGURE 2-8: BUS BASEPLATE HOLES

NOTE: Before drilling any holes, be sure that no underlying wires or tubes are in the way.

- c. Fasten Lift:
 - 1) Insert eight 4" x 3/8" carriage bolts through baseplate and vehicle floor.
 - 2) Install support tubes (4 ea.) to bolts underneath vehicle floor across baseplate, i.e., from 1 to 5, 2 to 6, etc., and secure lift to vehicle floor with 3/8" washers, lock washers and hex-nuts.
 - 3) Tightening carriage bolts requires special care to keep baseplate assembly from warping when secured to vehicle floor. If baseplate assembly warps, vertical arms will not be parallel. Corrections can be made by shimming at appropriate locations. To help prevent warping, tighten the eight carriage bolts to 28 ft. lbs. in following sequence:

2, 3, 6, 7, 1, 4, 5, 8

NOTE: Vertical arms must be parallel for proper operation. Adjust bolts as required. Best results are obtained when lift is mounted on plywood. Shims, although best avoided, may be used if required.

B. ELECTRICAL INSTALLATION

⚠ CAUTION

- Do not route a wire while it is connected to the battery.
- Route wires clear of moving parts, brake lines, and the exhaust system. Secure to the vehicle.
- When routing an electrical wire through vehicle floor or walls, use a grommet to protect wires from chafing.
- Check underside of vehicle before drilling to avoid damage to fuel lines, vent lines, brake lines, or wiring.

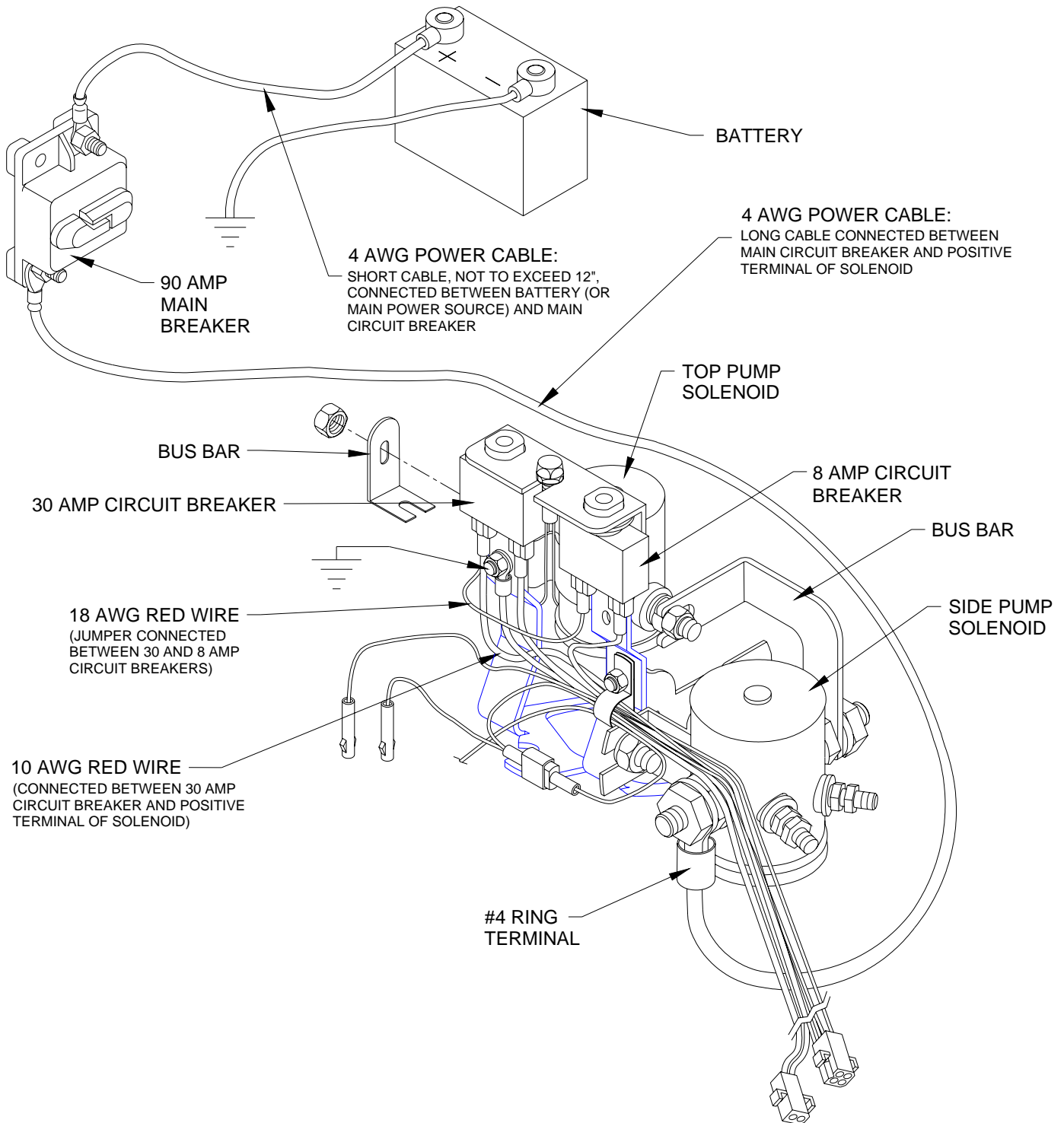



FIGURE 2-9: ELECTRICAL INSTALLATION DIAGRAM

1. INSTALL MAIN CIRCUIT BREAKER

- a. Disconnect battery.
- b. Mount main circuit breaker inside engine compartment near battery. Mount within 12 inches to minimize amount of unprotected cable. Avoid installing near a heat source.

2. ROUTE AND CONNECT MAIN POWER CABLE

 CAUTION
Check under-side of vehicle before drilling to avoid damage to fuel lines, vent lines, brake lines, or wiring.

NOTE: For applications where power cable is to pass through sheet metal, drill a 3/4" hole and use wire clamp provided. For applications where cable is to pass through plywood, drill a 1" hole and use black plastic grommet provided.

- a. Refer to **Figures 2-9 and 2-10**. Drill a hole through vehicle floor near or under pump solenoids so power cable can reach positive stud of side solenoid (the stud on side solenoid that is not connected to top solenoid with a bus bar). The hole should be drilled so that it is covered by the pump cover.

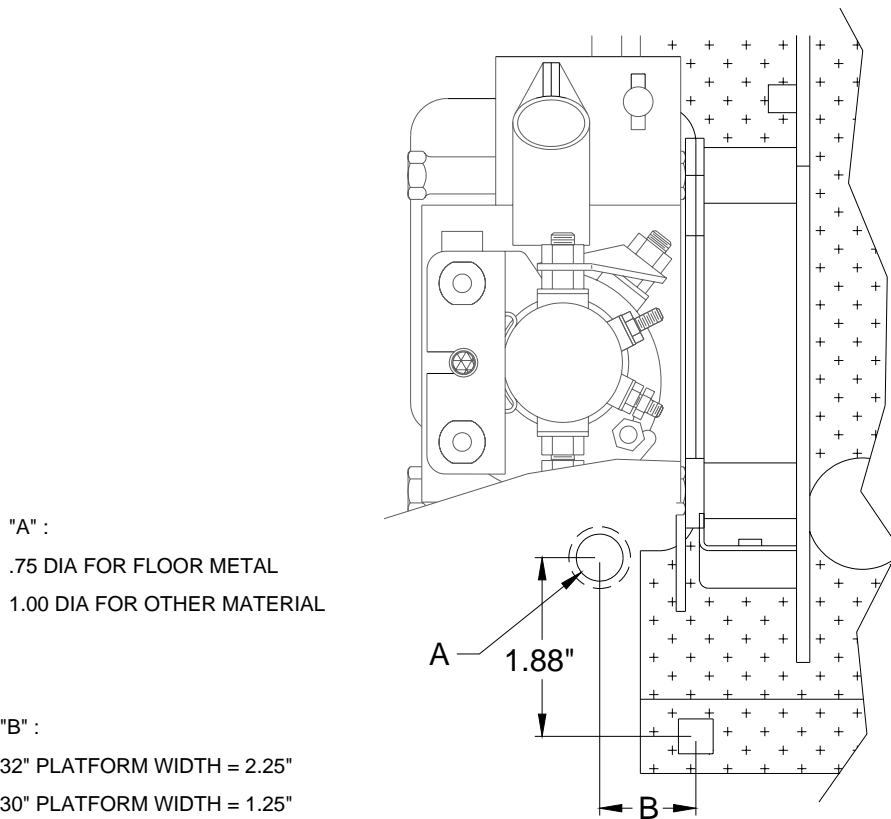



FIGURE 2-10: POWER CABLE ACCESS HOLE

NOTE: An 8 amp circuit breaker is provided for lift as a circuit protection device. Whatever circuit interface is supplied by the OEM, it should be capable of carrying 8 amps of continuous current.

- b. Install ring terminals (supplied) to each end of short power cable (12" long), and one ring terminal to one end, and one end only, of long power cable using an appropriate crimp tool (such as Ricon P/N 26553).
- c. Connect end of long 4 AWG power cable (with ring terminal) to main circuit breaker, then route power cable underneath vehicle floor and up through hole in floor.
- d. Verify that power cable is secure. Bind power cable to pump assembly harness and to pump motor using cable ties. Avoid pinch points, exhaust system, any moving parts, and brake lines.

 CAUTION
Be sure that there is no interference with any parts that could damage power cable or other wires in any way.

- e. Refer to **Figure 2-11**. Cut any excess wire from long cable, install remaining heavy ring terminal to unterminated end of long cable, and connect it to live side of solenoid. Verify that red wire from main circuit breaker (if applicable) is connected to positive solenoid pole.

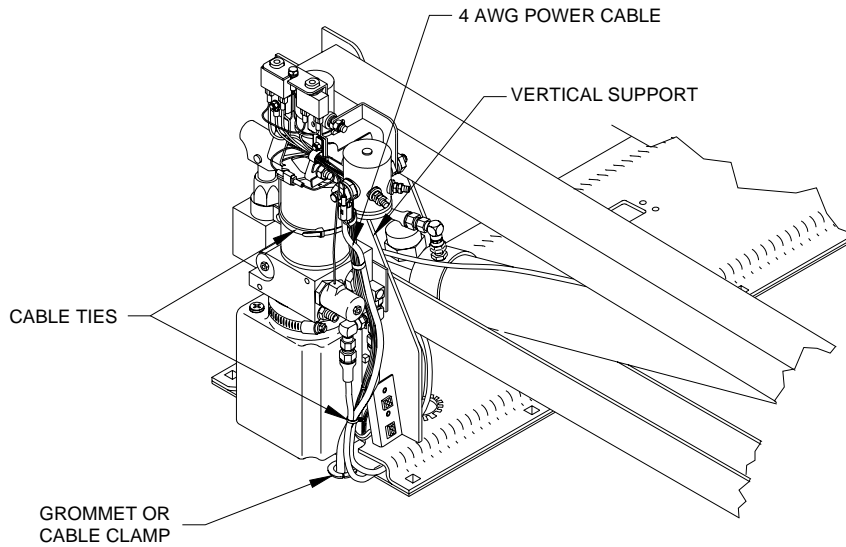

FIGURE 2-11: CABLE ROUTING

- f. Refer to **Figure 2-12**. Connect appropriate RICON lift control interface to lift and secure control cable to lift with supplied cable clamp.

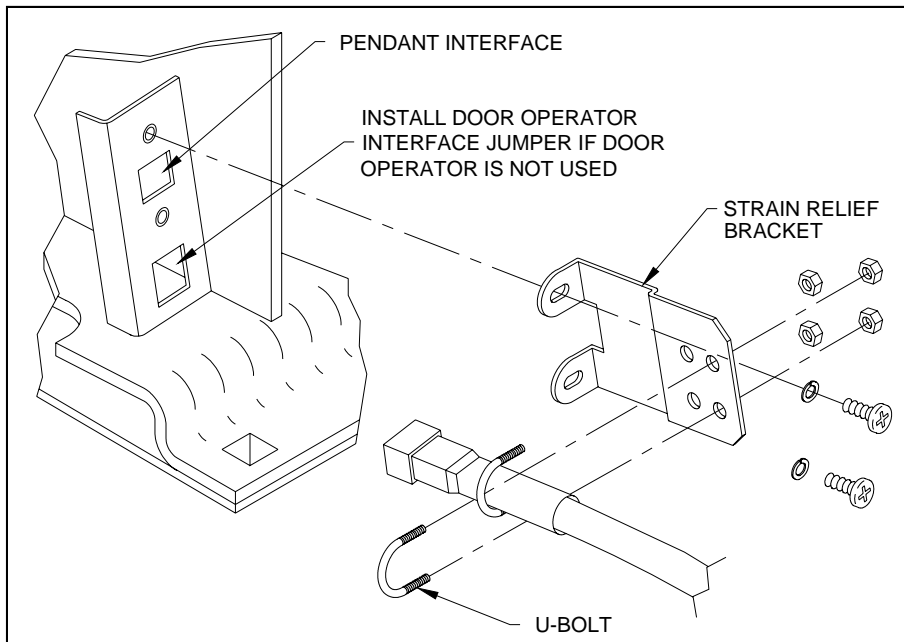

FIGURE 2-12: STRAIN RELIEF KIT

- g. For applications where a hand-held control pendant is used, it is essential that strain relief be installed. Connect a 12" cable from battery positive terminal to main breaker terminal closest to battery.
- h. Install wall portion of pendant dovetail clip in an appropriate safe location.

⚠ CAUTION

Be sure that harness does not interfere with any moving parts, or binds against any parts, or is pinched in any way.

3. GROUND CONNECTIONS

a. 12VDC Systems

12VDC powered lifts are chassis grounded and do not require a separate ground cable connection to battery. However, if lift electrical system is connected to chassis with a cable, the cable must be attached in a manner that provides a reliable electrical connection. If ground cable is attached to an existing ground circuit, the circuit must be capable of conducting an additional 90 amps to the negative battery terminal.

b. 24VDC Systems

- 1) Ricon recommends that a dedicated ground cable be used in 24VDC installations. A 4GA cable, or heavier, must be used.
- 2) Refer to **Figure 2-13**. The ground cable is connected from the negative stud (-) on pump motor to the negative battery terminal.

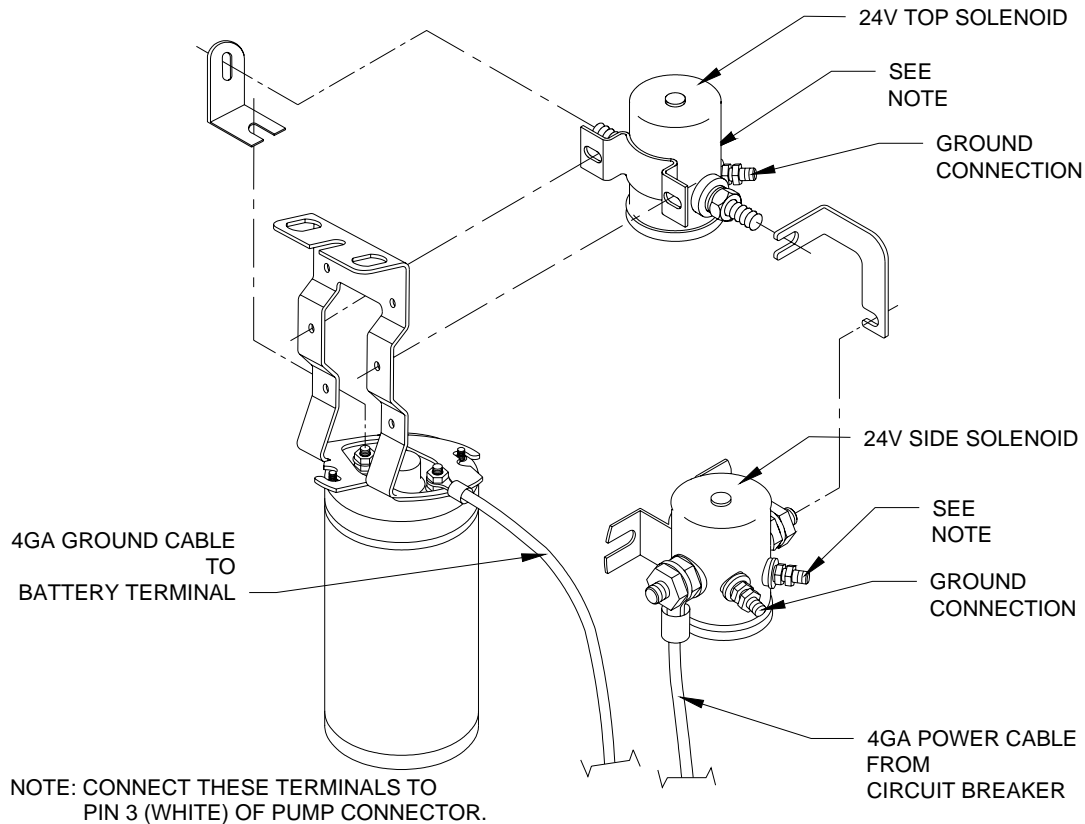

FIGURE 2-13: 24VDC DUAL SOLENOID WIRING

4. INSTALLATION OF INTERLOCK DEVICES NOT SUPPORTED BY RICON

An interlock device can be installed to prevent operation of the lift or vehicle when it is not safe to do so. **The interlock supplied by the installing Ricon dealer is not a Ricon product.**

Some interlock devices lock vehicle transmission in PARK (or neutral) when lift is deployed, or do not allow lift to be deployed unless vehicle transmission is in PARK (or neutral) and emergency brake is set. Other devices will stall vehicle engine if lift is deployed and emergency brake is released or transmission is shifted from PARK (or neutral). There may be other types of interlock devices that disable lift or vehicle to prevent unsafe lift operation.

Ricon is not aware of all available interlock products. For this reason it is very important that interlock products be properly installed so that they do not interfere with safe operation or create any other hazards.

The installer must verify that none of the original equipment circuit breakers, fuses, or solenoids are bypassed, removed, or altered. Be sure that no wires are left frayed or hanging loose after installation of an interlock device. If you have any questions about proper installation of interlock devices, please contact our Product Support Department.

 **WARNING**

DO NOT OPERATE LIFT UNLESS YOU ARE CERTAIN THAT THE INTEGRITY OF LIFT ELECTRICAL CIRCUITS HAS BEEN MAINTAINED.

 **CAUTION**

Wiring attached directly to the positive battery terminal is not protected against short circuits and must be kept to a length of 12" or less. The wiring must be routed in a manner that prevents pinching or abrasion by vehicle parts. The power source wire for the interlock circuit must be connected to a protected supply such as a dedicated accessory on an existing fuse panel.

Ricon recommends one of the following interlock methods:

a. **INTERLOCK METHOD #1**

Refer to **Figure 2-14**. This method interrupts power to the lift hand control pendant. It does not require additional circuit protection, but does require a modification to lift harness.

- 1) Disconnect battery.
- 2) Remove piggyback spade connector wire from OUTPUT side of 8 amp circuit breaker (refer to decal on circuit breaker).

NOTE: The OUTPUT side of breaker must be used to avoid possibility of an electrical short.

- 3) Connect female spade connector of interlock circuit provided by installer to OUTPUT side of 8 amp breaker using 16 AWG or larger wire.

NOTE: All connectors provided on interlock circuit must be a fully insulated type.

- 4) Cut piggyback connector from light assembly and female spade connector from signal power wire. Strip both wires about ½" being careful not to nick conductor. Crimp both wires in a single 1/4" fully insulated female spade connector designed for use on 14-16 AWG wire.
- 5) Connect male spade connector of interlock circuit to female spade connector added to harness in above step.
- 6) Dress wires in such a way as to not allow rubbing or chafing of insulation, and so there is no strain at any terminals or body of light.

b. **INTERLOCK METHOD #2**

Refer to **Figure 2-15**. This method interrupts power between lift 8 amp breaker and vehicle battery. It requires circuit protection to be provided by installer.

- 1) Disconnect battery.
- 2) The cable leading to applicable circuit protection from battery must be at least 16 AWG or larger, and must not exceed 12" in length.
- 3) Connect INPUT side of interlock circuit to OUTPUT side of circuit protector using 16 AWG or larger wire.

- 4) If an optional 30 amp circuit breaker has been installed next to 8 amp breaker, completely remove the 18 AWG wire connecting INPUT sides of 30 amp and 8 amp circuit breakers. To do this, the spade connector must be removed from 8 amp INPUT and 18 AWG wire must be cut as close as possible to 30 amp INPUT connector, since it is crimped to that connector along with a 10 AWG wire.
- 5) Connect OUTPUT side of interlock circuit to INPUT side of lift's 8 amp circuit breaker using 16 AWG or larger wire.
- 6) Re-connect battery.

c. **INTERLOCK METHOD #3**

Refer to **Figure 2-16**. This method interrupts power between pump solenoid and battery. This cuts all power to lift. It requires circuit protection to be supplied by installer.

- 1) Disconnect battery.
- 2) Disconnect 4 AWG power cable from main breaker at pump solenoid.
- 3) Connect cable to one of terminal posts of interlock solenoid.
- 4) Connect other terminal post of interlock solenoid to empty terminal post of pump solenoid using 4 AWG wire.
- 5) Connect circuit protector provided by installer (should be 8 amp, maximum) to main power cable coming from battery (which should be disconnected at this time) using wire at least 16 AWG or larger, not to exceed 12" in length. Be sure that wiring cannot pinch or chafe.
- 6) Connect OUTPUT side of circuit protector to INPUT side of interlock circuit provided by installer using 16 AWG or larger wire.
- 7) Connect OUTPUT side of interlock circuit to coil terminal of solenoid using 16 AWG or larger wire.
- 8) Be sure that interlock solenoid is properly grounded. If a separate grounding post is provided, connect a 16 AWG wire from ground post to a suitable chassis ground. If coil is grounded through body of solenoid, be sure that solenoid is mounted to a suitable chassis ground.
- 9) Reconnect battery.

INSTALLATION MUST CONFORM TO SAE SPECIFICATIONS:
 J553: CIRCUIT BREAKERS
 J1292/SEC. 2.9: WIRE ASSEMBLY
 J1292/SEC. 2.10/PARAGRAPH 2.10.1: CIRCUIT PROTECTION

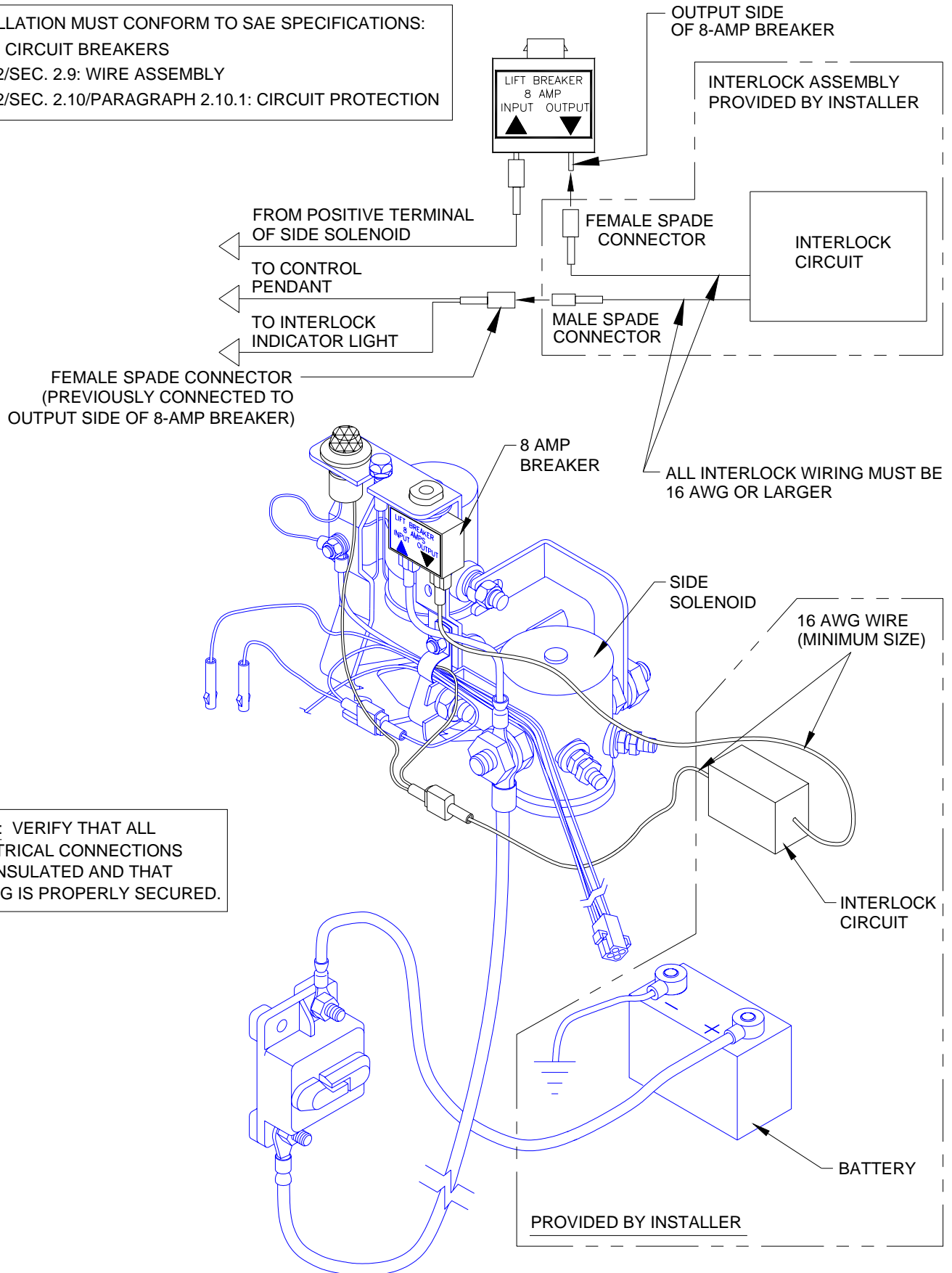
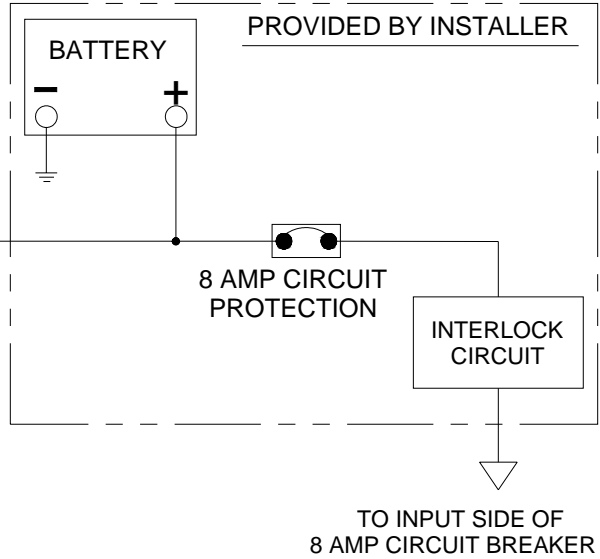

FIGURE 2-14: INTERLOCK METHOD #1 - INTERRUPT POWER TO CONTROL PENDANT

INSTALLATION MUST CONFORM TO SAE SPECIFICATIONS:
 J553: CIRCUIT BREAKERS
 J1292/SEC. 2.9: WIRE ASSEMBLY
 J1292/SEC. 2.10/PARAGRAPH 2.10.1: CIRCUIT PROTECTION



NOTE: VERIFY THAT ALL ELECTRICAL CONNECTIONS ARE INSULATED AND THAT WIRING IS PROPERLY SECURED.

* NOTE: REMOVE EXISTING 18 AWG JUMPER CONNECTED BETWEEN 8 AMP AND 30 AMP CIRCUIT BREAKERS.

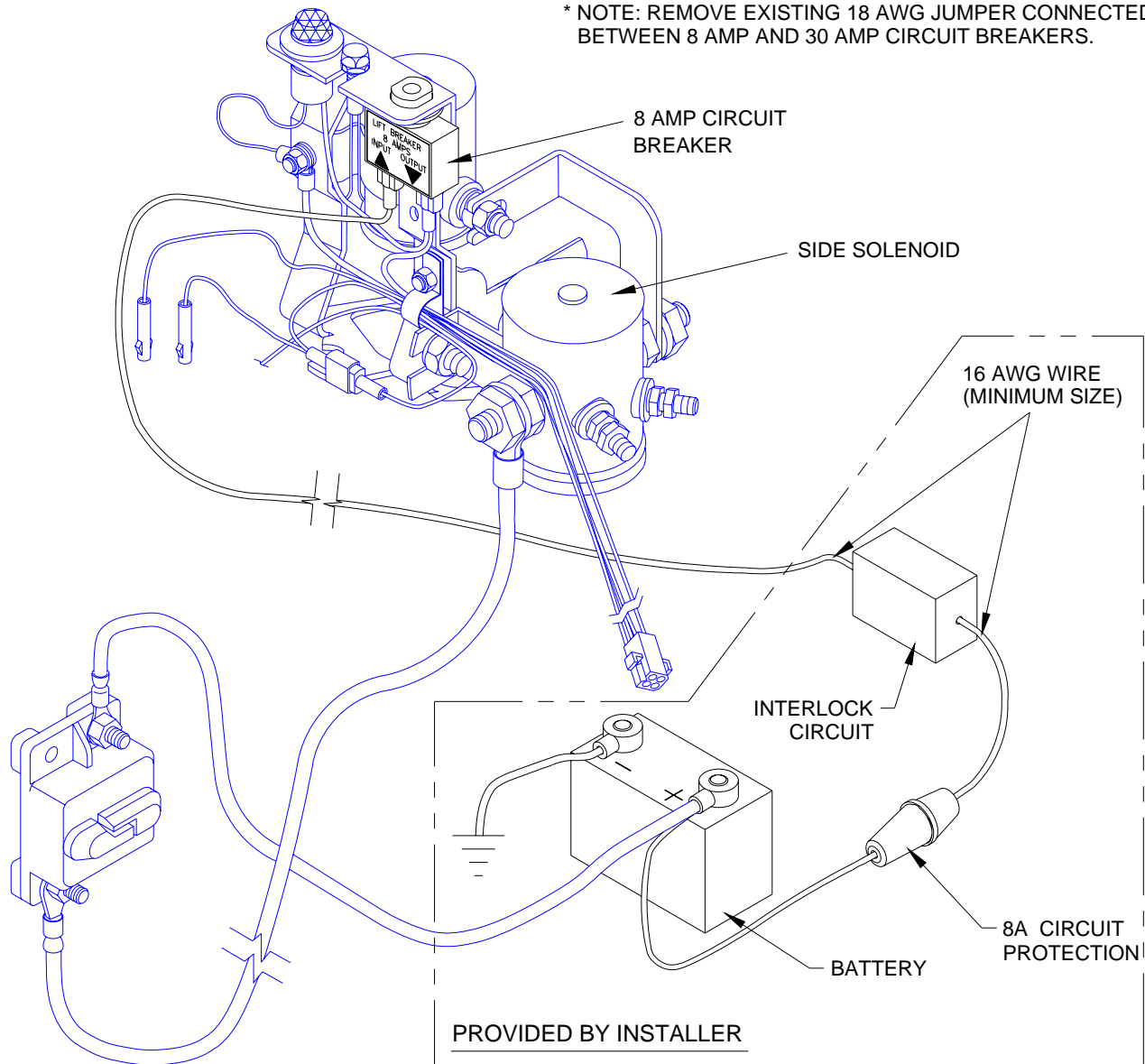
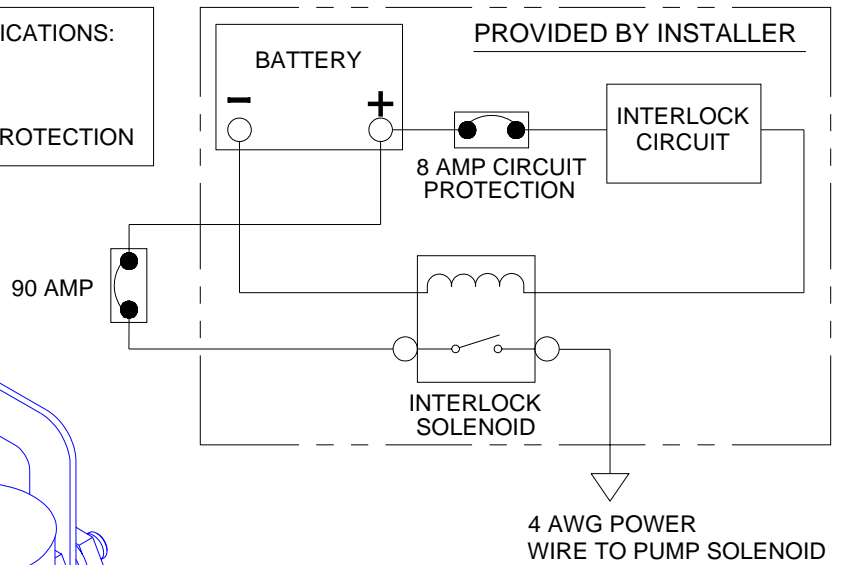
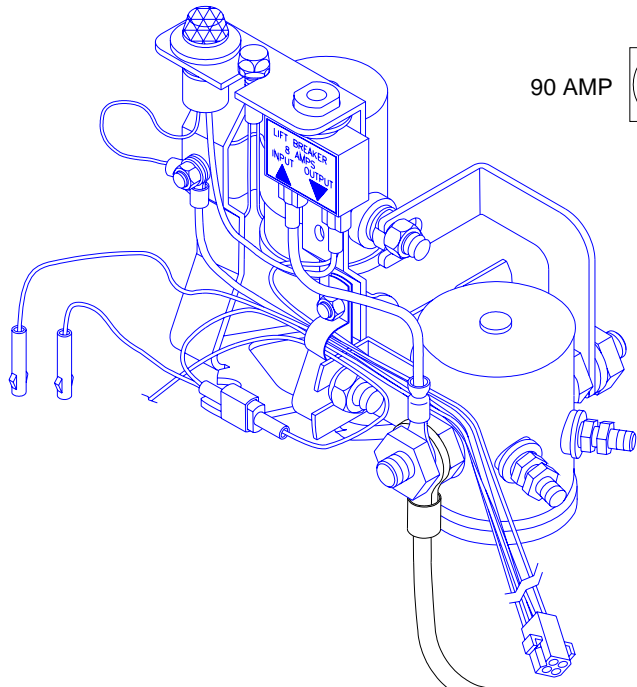

FIGURE 2-15: INTERLOCK METHOD #2 - INTERRUPT POWER TO 8 AMP CIRCUIT BREAKER

INSTALLATION MUST CONFORM TO SAE SPECIFICATIONS:
 J553: CIRCUIT BREAKERS
 J1292/SEC. 2.9: WIRE ASSEMBLY
 J1292/SEC. 2.10/PARAGRAPH 2.10.1: CIRCUIT PROTECTION



NOTE: VERIFY THAT ALL ELECTRICAL CONNECTIONS ARE INSULATED AND THAT WIRING IS PROPERLY SECURED.

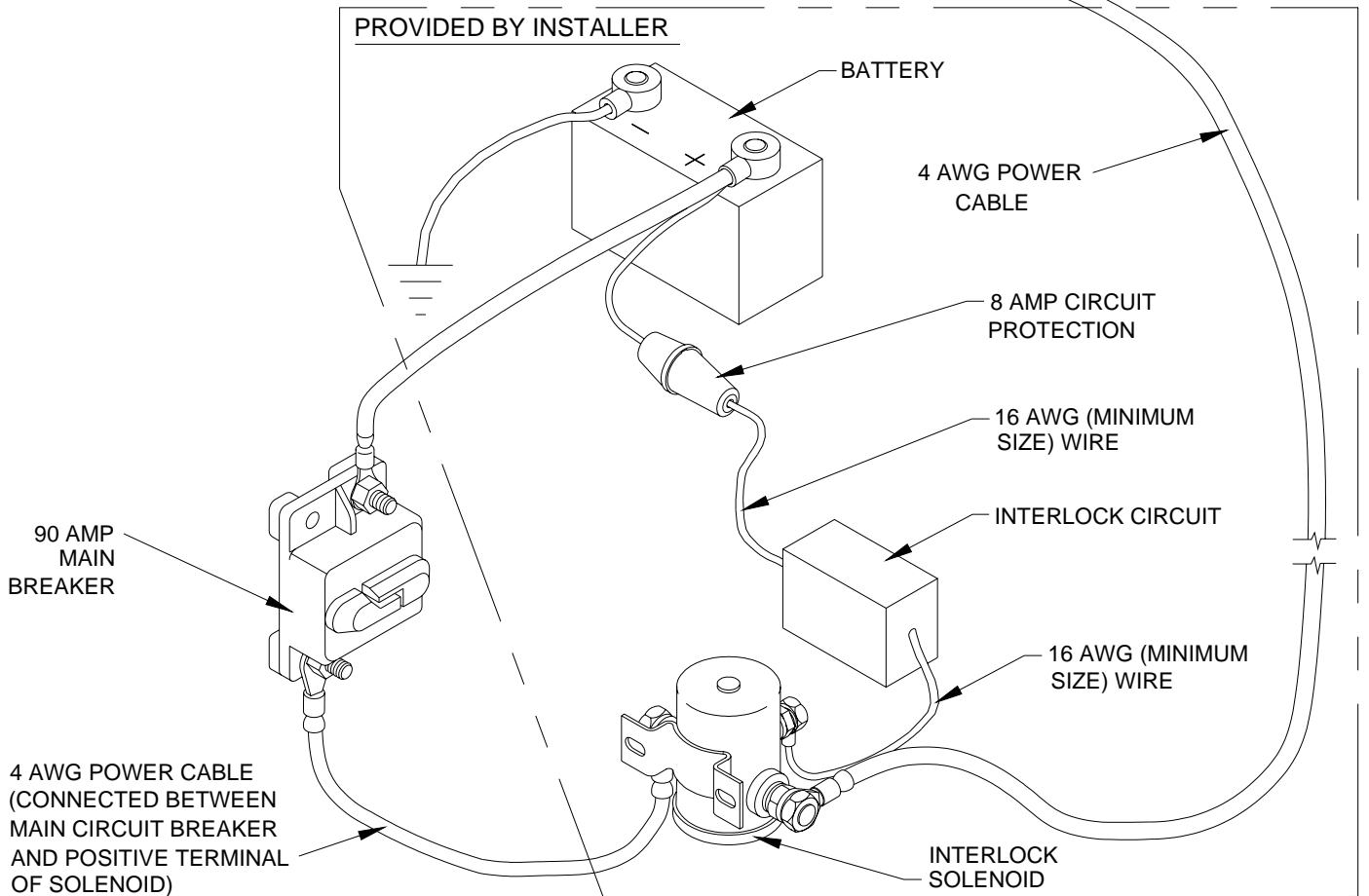

FIGURE 2-16: INTERLOCK METHOD #3 - POWER INTERRUPT

C. FINAL ADJUSTMENTS

1. LIMIT SWITCH ADJUSTMENT

For lift limit switch adjustment, refer to **Figures 2-17, 2-18**, and the following procedure. Contact Ricon Product Support for assistance.

NOTE: To avoid operational “dead-spots”, always adjust OUT CUTOFF SWITCH **before** UP CUTOFF SWITCH.

NOTE: When loosening adjustment screws, apply enough pressure to screw to move block instead of screw. (The block might stick if insufficient pressure is applied to screw.)

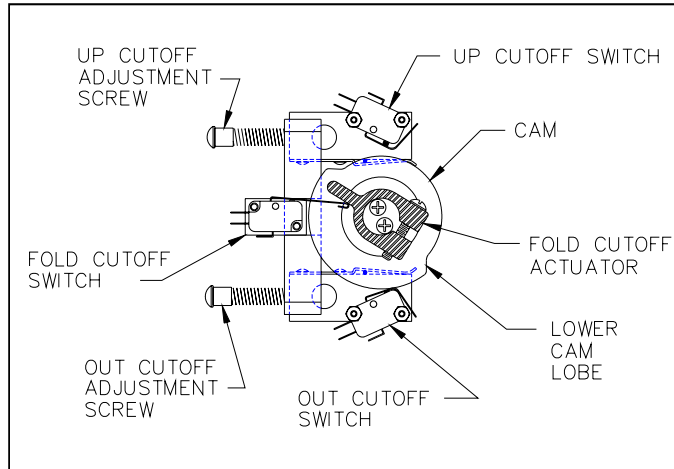

FIGURE 2-17: LIMIT SWITCH ADJUSTMENT DIAGRAM

- a. Fully DEPLOY platform.
- b. Adjust UP CUTOFF ADJUSTMENT SCREW and OUT CUTOFF ADJUSTMENT SCREW 6-8 turns **counter-clockwise** and then push screws FORWARD.
- c. Cycle platform to STOW then DEPLOY.
- d. When in DEPLOY position, platform should stop at an angle and NOT even with vehicle floor. If not, turn OUT CUTOFF ADJUSTMENT SCREW an additional 2-3 turns **counter-clockwise**, push screw forward, STOW then DEPLOY platform, then repeat this step.
- e. Cycle platform to UP position.
- f. When in UP position, platform should stop short of vehicle floor level. If not, turn UP CUTOFF ADJUSTMENT SCREW an additional 2-3 turns **counter-clockwise**, push screw forward, cycle platform DOWN then UP, then repeat this step.
- g. Cycle platform to STOW then DEPLOY.
- h. Push and hold control pendant DEPLOY switch. Slowly turn OUT CUTOFF ADJUSTMENT SCREW **clockwise** until platform “jogs” down to vehicle floor level. Make sure that clearance between knuckle actuator saddle and parallel arm is 1/8" minimum (distance may be 1/2" maximum and unequal from left or right arm), stop turning screw and release DEPLOY switch.

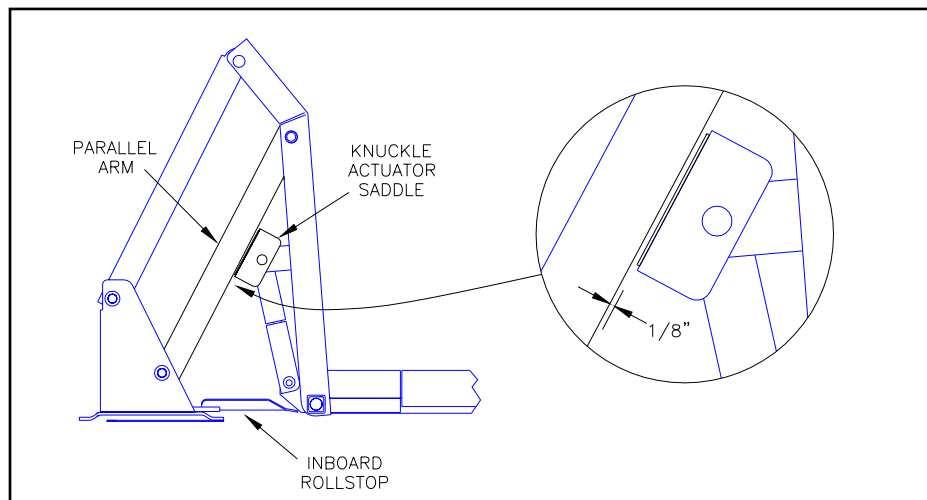

FIGURE 2-18: LIMIT SWITCH ADJUSTMENT CLEARANCE

- i. Position platform DOWN to ground level then UP until it stops.
- j. Push and hold control pendant UP switch. Slowly turn UP CUTOFF ADJUSTMENT SCREW **clockwise** until platform "jogs" up to vehicle floor level. Make sure that clearance between knuckle actuator saddle and parallel arm is 1/8" minimum (distance may be 1/2" maximum and unequal from left or right arm), stop turning screw and release UP switch.

NOTE: If lift does not operate after 1-2 full turns of adjustment screw, cycle platform UP and DOWN (The UP CUTOFF SWITCH is less sensitive than OUT CUTOFF SWITCH.)

- k. Cycle platform through all functions (DEPLOY, DOWN, UP, and STOW) to verify correct adjustment. Refer to **Table 2-1** if necessary.

TABLE 2-1: LIMIT SWITCH ADJUSTMENT CHART			
COMPONENT	SYMPTOM	CORRECTIVE ACTION	ADJUSTMENT PROCEDURE
Fold cutoff actuator	Lift does not fold tightly.	Rotate collar counter-clockwise.	With lift fully folded (handrails should be folded tight against vertical arms), rotate actuator so that fold cutoff leg barely trips fold cutoff switch.
	Pump runs continuously.	Rotate collar clockwise.	Test lift. Pump should cutoff when lift is folded tight.
Up cutoff adjustment screw	Lift stops low.	Adjust screw clockwise.	Adjust up cutoff switch so that lift stops just before first knuckle actuator saddle or roller touches underside of lower parallel arm. (Saddle or roller should be about 1/8" from lower parallel arm.)
	Lift stops high.	Adjust screw counter-clockwise.	
Out cutoff adjustment screw	Lift stops low.	Adjust screw counter-clockwise.	Adjust lower limit switch so that lift stops just below "Up" cutoff described in above step. This will give the necessary overlap to avoid "dead" spots.
	Lift stops high.	Adjust screw clockwise.	
END OF TABLE			

2. PLATFORM TILT ADJUSTMENT

Correct platform tilt adjustment is crucial for proper platform rollstop operation, but cannot be adjusted at factory. Factors such as vehicle floor height, lift tilt angle and stiffness of vehicle springs will vary installation geometry.

- a. Deploy and lower lift platform to a position halfway between vehicle floor level and ground level.
- b. Refer to **Figure 2-19**. Adjust left and right platform set screws until platform is level at zero (0) degrees. Turn set screws clockwise to angle front-end of platform upward, or counter-clockwise to angle downward.
- At ground level, the distance between heel of platform and ground should be 3/4" to 1". This distance should be measured at initial point of rollstop's full deployment.

NOTE: Adjust set screws on both sides of platform simultaneously and evenly to ensure proper leveling of platform.

- c. Repeat steps a and b as required to achieve proper rollstop operation.

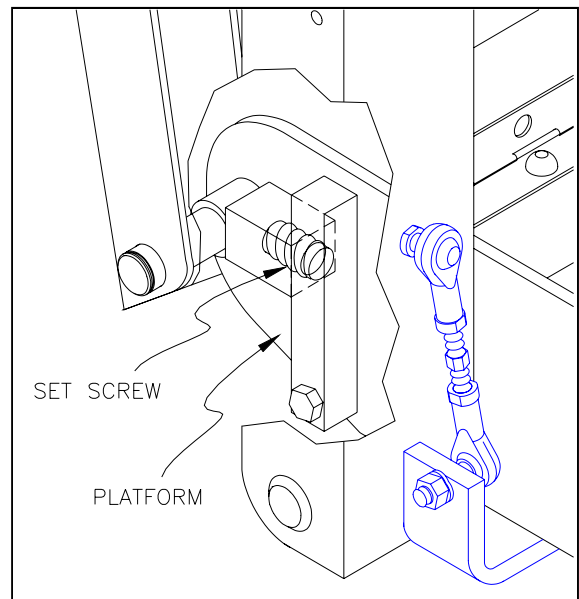

FIGURE 2-19: PLATFORM SET SCREWS

3. SPLIT PLATFORM TIE ROD ASSEMBLY INSTALLATION AND ADJUSTMENT

CAUTION

Stowing platform without tie rod assemblies installed will cause severe damage to platform. Do not attempt to stow platform before tie rod assemblies are installed and adjusted.

All S-Series split platform model lifts are equipped with tie rod assemblies, which open the platform panels as lift is stowed. Correct adjustment of these tie rods is needed to prevent tie rod breakage.

- a. Lower platform below vehicle floor level.
- b. Refer to **Figure 2-20**. Assemble rod end attachment brackets to left and right tie rod assemblies at right-hand ball joint.

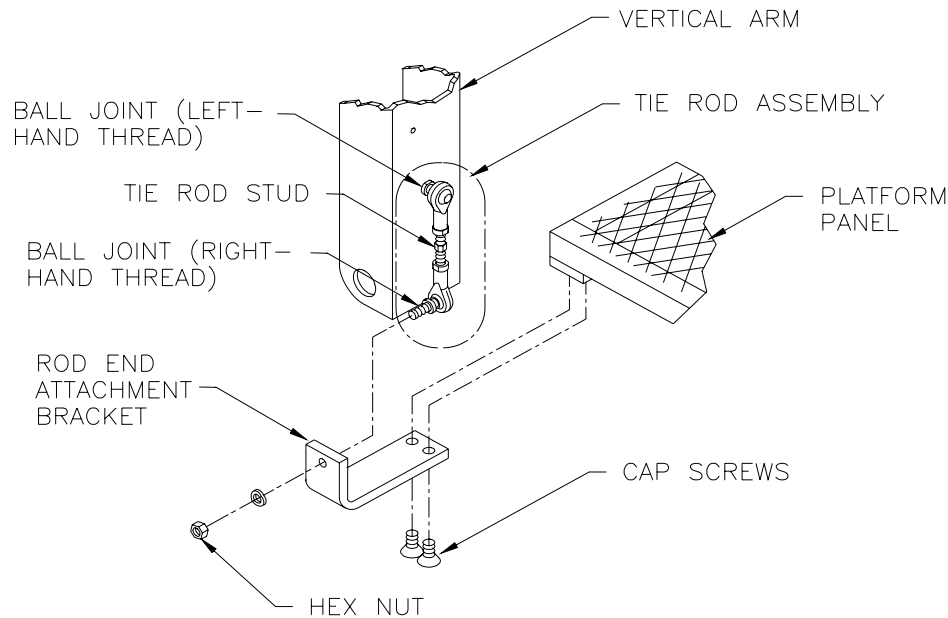

FIGURE 2-20: TIE ROD INSTALLATION

NOTE: Correct positioning of ball joint on inside of rod end attachment bracket.

- c. Assemble rod end attachment brackets to corresponding platform panels using screws and Loc-TITE blue.

CAUTION

Do not lengthen tie rod stud to point where panel will lift off its tab support (at center of lift fork).

- d. Adjust left tie rod assembly. Adjust tie rod stud until nearly all of link free-play is out by lengthening rod.

NOTE: The left platform panel should be adjusted first so that it is slightly higher than right platform panel. This will ensure proper insertion of left panel joining pin through hole in right platform panel.

- e. Raise platform to point just before panel joining and adjust right tie rod assembly for proper joining.
- f. Lower platform below vehicle floor level.

NOTE: There must be no tension or compression on tie rod assemblies when platform is at, or below, the vehicle floor level.

- g. Stow and deploy lift several times to ensure both platform panels join correctly. Readjust, if necessary, and then tighten lock nuts against ball joints to secure adjustment.

4. PLATFORM PRESSURE SWITCH CHECK AND ADJUSTMENT

(serial no.'s 104,000 to present)

Correct adjustment of this pressure switch is required to prevent platform from folding into vehicle when there is a load of 50 lbs, or more, on the platform.

- a. Refer to **Figure 2-21**. Deploy and lower platform to ground. Place a 23Kg (50 lb.) load in center of platform and then raise platform to floor level. Press and hold STOW switch.

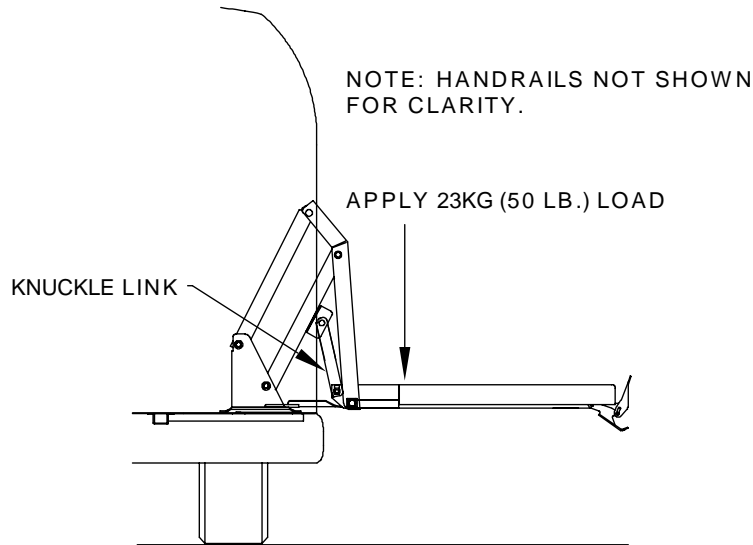

RSM0003601

FIGURE 2-21: PRESSURE SWITCH TEST AT FLOOR LEVEL

NOTE: Weight must be 23kg (50 lbs.) and placed 152mm (6 inches) from rear edge of platform mesh as shown in **Figure 2-23**.

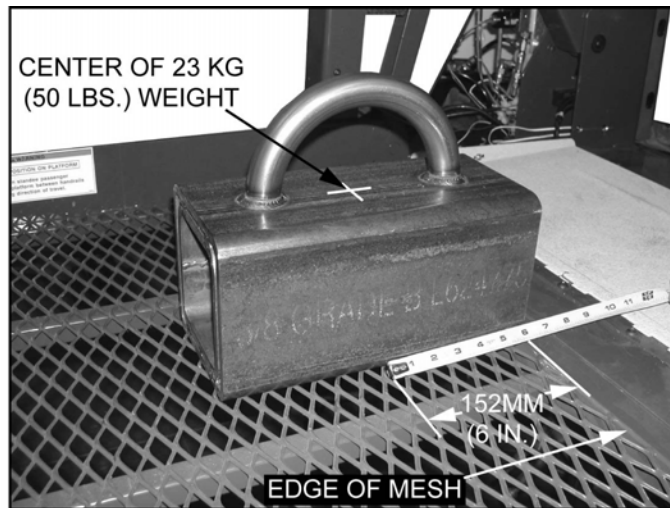

FIGURE 2-23: 23KG (50 LBS.) WEIGHT PLACEMENT ON PLATFORM

- b. Place a 152mm (6 in.) x 152mm (6 in.) x 305mm (12 in.), 23kg (50 lbs.) load on the rear, center portion of platform then stow platform by pressing and holding the STOW switch.
- c. Refer to **Figure 2-24**. If an alternate weight is to be used, the center of the weight must be 152mm (6 in.) from the rear edge of the platform mesh.

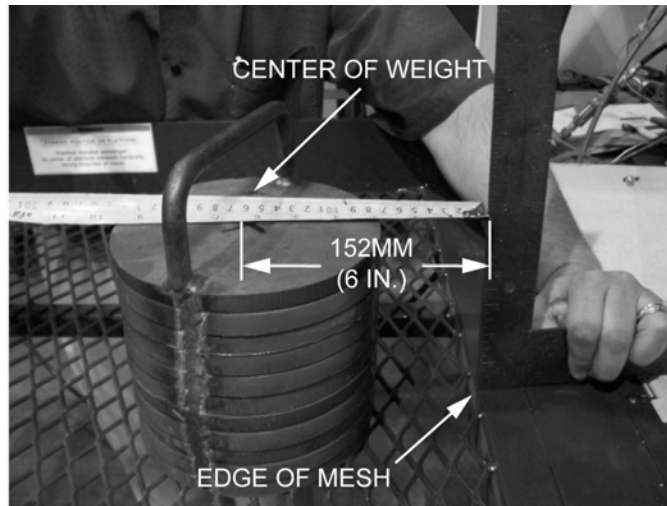
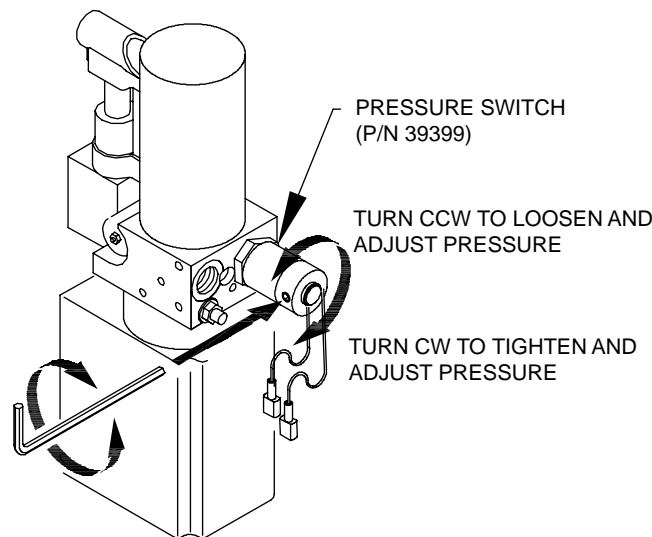

FIGURE 2-24: ALTERNATE 23KG (50 LB.) WEIGHT

- d. The pressure switch is correctly set if pump motor shuts off when attempting to stow the lift, preventing inward movement of the platform.
- e. The pressure switch is not correctly set if pump motor does NOT shut off and there is inward movement of the platform. Adjustment of the pressure switch will be required.

NOTE: If adjustment is necessary then pressure switch must be adjusted as shown in **FIGURE 2-25**.

- f. Refer to **Figure 2-25**. Remove the 1/4-20 x 1.00" set screw (with hex recess) from end of pressure switch to gain access to adjustment screw. Save screw for reinstallation.



RSM0005000

FIGURE 2-25: HYDRAULIC PUMP WITH PRESSURE SWITCH

- g. Turn the hydraulic pressure switch enclosure 1/8 of a turn **counterclockwise** (CCW), by hand to reduce the pressure.

NOTE: Turn the hydraulic pressure switch enclosure **clockwise** (CW) to increase pressure and **counterclockwise** (CCW) to decrease pressure, by hand.

- h. Stow platform and observe if the motor shuts off.
- i. If the motor does not shut off, turn the hydraulic pressure switch enclosure 1/8 of a turn **counterclockwise** (CCW), by hand to reduce the pressure.

NOTE: The lift should NOT stow or have inward movement with the weight on the platform.

- j. Repeat pressure switch adjustment as necessary to achieve correct setting.
- k. Tighten the locking set screw when the correct pressure setting is achieved.

5. PLATFORM LOAD SENSOR SWITCH ADJUSTMENT (serial no.'s 0 - 103,999)

This procedure provides for setting platform load sensor switch to prevent lift from folding past vehicle floor level when a load of 50 lbs is on center of platform.

- l. Refer to **Figure 2-23**. Place your left hand around knuckle vertical link assembly as shown; link is located on left side of lift.
- m. Loosen two hex-bolts shown.
- n. Exert a light downward pressure through your left-hand fingers onto load sensor bar, and retighten hex-bolts.
- o. Refer to **Figure 2-21**. To verify proper load sensor switch operation, deploy and lower platform to ground. Place a 50 lb. load in center of platform and then raise platform to floor level. Press and hold STOW switch.

NOTE: If pump motor does not stall or clicks off and on excessively, loosen two hex bolts, push down further on load sensor bar, and re-tighten bolts.

- p. Repeat above two steps as necessary until pump motor stalls (i.e., load sensor switch is activated, preventing lift platform from folding past vehicle floor level).

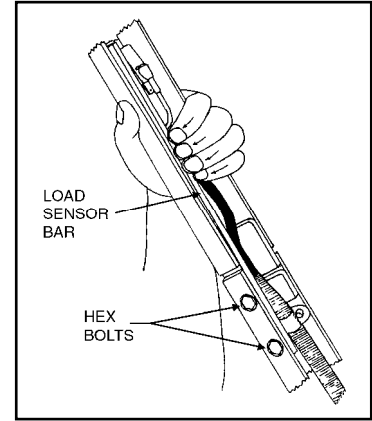

FIGURE 2-23: LOAD SENSOR ADJUSTMENT

D. VERIFY INSTALLATION

- Be certain that no vehicle components interfere with operation of lift.
- The lift is designed to carry the weight of a wheelchair and its passenger. The vehicle structure must be capable of supporting all loads produced during lift operation, as well as those forces caused by motion of vehicle when it is driven.

CAUTION
<ul style="list-style-type: none"> • Do not operate lift when test weight is on platform. This load test is designed to test the lift mounting method, not the lift capacity. Remove test weight immediately after test. • Vehicle suspension will compress and vehicle will lean when test weight is placed on platform. If weighted platform contacts ground, remove weight, raise platform, and retest.

- The lift must be test loaded to 125% of its rated 800 pound load capacity to verify integrity installation. Position lift platform 2" - 6" above the ground, place 1000 pounds in center of platform, and inspect lift mounting points. REMOVE TEST WEIGHT.
- Run lift through several complete cycles while checking for proper operation.

E. CUSTOMER ORIENTATION

<p>IMPORTANT</p> <p>- Customer Orientation -</p> <p>Ricon Sales or Service Personnel must review the warranty card and Operator manual with the customer to be certain they understand safe operation of the lift. The customer should be instructed to follow the operating instructions without exception.</p>
--

- Refer to **Figure 2-27** on next page and verify that all decals are properly located and affixed as shown.

NOTE: The installing dealer affixes Operating Instructions decal to vehicle in a location clearly visible to lift operator.

This page intentionally left blank.

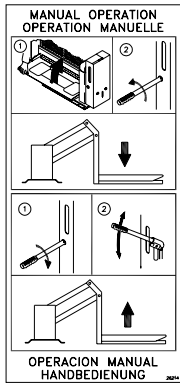

MANUAL OPERATION
DECAL
PN 26214

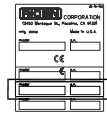

PART OF SERIAL NUMBER
STICKER (LOCATED ON
INNER SIDE OF HYDRAULIC
CYLINDER, ONLY RICON
REPLACEABLE)

CAT CERTIFICATION
SHIPPING DECAL
PN 26173 (CALIFORNIA
MODELS ONLY)

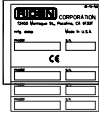

PART OF SERIAL
NUMBER STICKER
(ONLY RICON
REPLACEABLE)



MAXIMUM
LOAD
DECAL
PN 26182

PUMP COVER DECAL
PN 26292



S-SERIES
PATENT NO. DECAL
PN 32-10-173

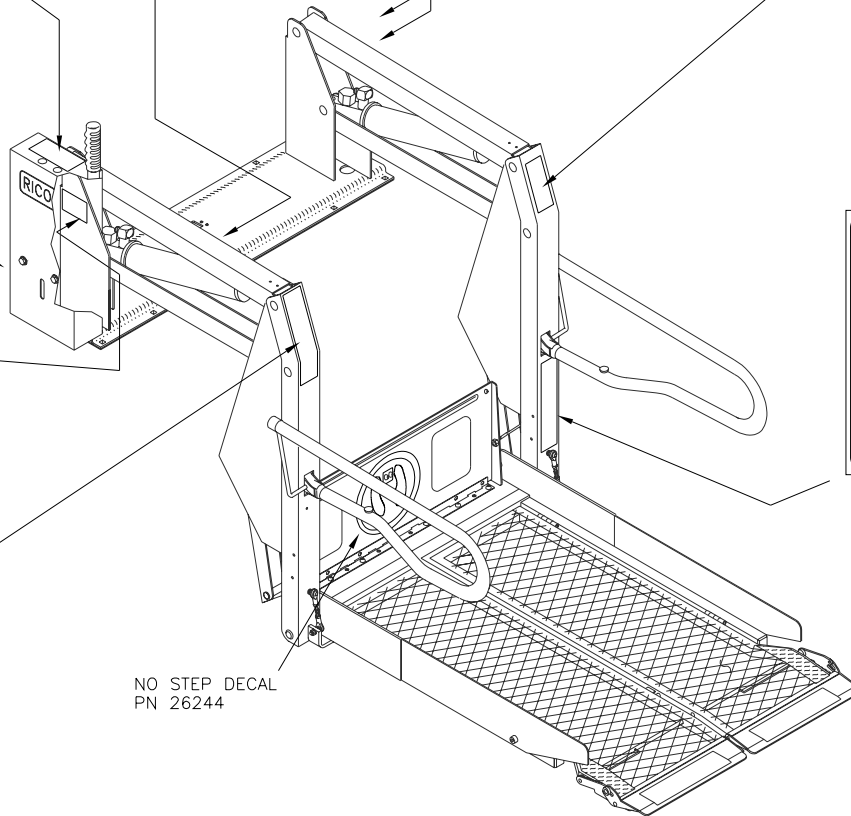

RICON LOGO
DECAL
PN 32-10-152

NO STEP DECAL
PN 26244

**S-SERIES EXPORT USE
WHEELCHAIR LIFTS**

WARNING

- 1) Improper use of lift can result in personal injury. User must read and follow operating instructions. In some models, forward motion of upper basket are variable from:

RICON CORP.
12450 MONTAGUE ST.
PACONIA, CA 95351
(816) 899-7558
(800) 322-2854

- 2) Do not exceed rated load of 800 lb (364 kg).
- 3) Prior to use, inspect wheelchair lift for proper function, correct maintenance, or damage. If a problem exists, do not use lift, return to an authorized dealer for repair.

Ricon Corp. disclaims liability for damage or personal injury resulting from lift modification, lack of maintenance, repair, negligence, abuse or failure to follow lift operating instructions.

**OPERATING INSTRUCTIONS
(READ AND OBEY CAREFULLY)**

Deploy Lift:

- 1) Fully open doors.
- 2) Activate **DOWN** switch to unfold platform to vehicle floor level.
- 3) Activate **UP** switch to raise platform to ground level.

Enter Vehicle:

- 1) Enter platform carefully facing outward if possible and **LOCK WHEELCHAIR BRAKES**. (CAUTIONS See page 6)
- 2) Fasten Occupant Restraint Belt.
- 3) Activate **UP** switch to raise platform to vehicle floor level.
- 4) Release wheelchair brakes and enter vehicle.

Exit Vehicle:

- 1) Fasten Occupant Restraint Belt.
- 2) Enter platform carefully facing outward if possible and **LOCK WHEELCHAIR BRAKES**. (CAUTIONS See page 6)
- 3) Activate **DOWN** switch to lower platform to ground level.
- 4) Release wheelchair brakes and exit vehicle.

Stow Lift:

- 1) Activate **DOWN** switch to fold platform, pinch lift stop automatically when completely folded.
- 2) Close door(s).

Standards:

Standards should carefully read in center of platform, facing direction of travel (into or out of vehicle) and firmly grasp handrail.

MANUAL OPERATION

- 1) See instructions in user's cover and in Oper Manual.

CAUTION

Keep others clear of lift when operating. Be certain vehicle is safely parked before using lift. Occupant Restraint Belt should always be fastened before operating lift. Wheelchair should be positioned in center of platform so it does not interfere with table raising operation and prevent it from locking.

OPERATING
INSTRUCTIONS
DECAL
PN 261743

FIGURE 2-27: EXPORT LIFT DECAL LOCATIONS AND PART NUMBERS

III. S-SERIES EXPORT MAINTENANCE AND REPAIR

Regular maintenance of the RICON S-Series Export Use Wheelchair and Standee Lift with Folding Platform will help optimize its performance and reduce the need for repairs. This chapter contains lubrication and cleaning instructions, a maintenance schedule, a troubleshooting section, and electrical and hydraulic diagrams.

⚠ CAUTION

This Ricon product is highly specialized. Maintenance and repairs must be performed by a Ricon authorized dealer or qualified service technician using Ricon replacement parts. Modifying or failing to properly maintain this product will void warranty, and may result in unsafe operating conditions.

A. LUBRICATION

⚠ CAUTION

Do not lubricate motor or other electrical components. Lubrication of electrical components can collect dust and debris which can cause short circuits.

Lubrication should be performed at least every six months, or sooner depending on usage. Refer to **Figure 3-1** and the following Maintenance Schedule. Lubricate lift at points indicated with the lubricants specified. Make sure that platform tie-rods are free of debris, clean, and lubricated.

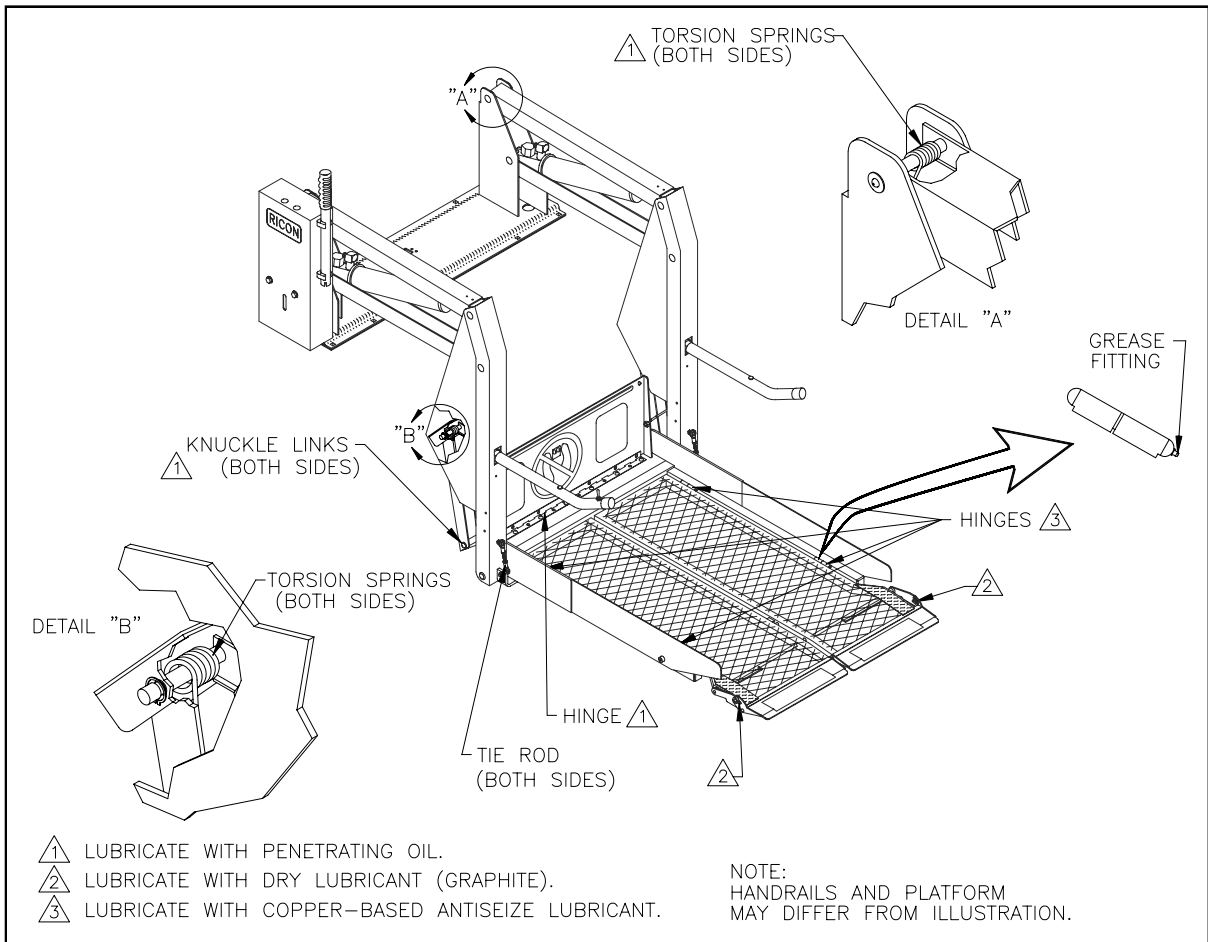

FIGURE 3-1: LIFT LUBRICATION POINTS

B. CLEANING

Regular cleaning with mild soap (i.e. dish soap, car wash liquid) and drying thoroughly will protect painted surfaces. Cleaning is especially important in areas where roads are salted in winter. Make sure that lift pivot points remain clear and clean prior to lubrication.

C. MAINTENANCE SCHEDULE

Under normal operating conditions, maintenance inspections are required at least every six months (1750 cycles) and a thorough inspection should be performed at service intervals referenced in **Table 3-1**. Service should be increased under conditions of heavier use (more than 10 cycles per day).



TABLE 3-1: MAINTENANCE SCHEDULE	
SERVICE POINT	ACTION TO PERFORM
DAILY SAFETY CHECK	
Overall condition	Listen for any abnormal noises as lift operates (i.e., grinding or binding noises).
Control pendant	Check that control pendant is not damaged and cable connectors are tight.
TWO-WEEK SAFETY CHECK	
Overall condition	<ul style="list-style-type: none"> Listen for any abnormal noises as lift operates (i.e., grinding or binding noises). Inspect underside of vehicle to ensure nothing is out of the ordinary.
Control pendant	Check that control pendant is not damaged and cable connectors are tight.
Electrical wiring	Inspect the electrical wiring for frayed wires, chaffed wires, loose connectors, etc.
Vehicle interlock	Place vehicle in NON-INTERLOCK mode and attempt to operate lift.
Decals	Be certain that all lift decals are affixed properly, clearly visible and legible. Replace if necessary.
Handrails	Be certain that all handrail fasteners are properly tightened.
Lift mounting and support points	<ul style="list-style-type: none"> Be certain that all lift mounting and support points are in proper order and free from damage. Be certain that all mounting bolts are sufficiently tight.
Main lifting pivots	Be certain all traveling frame pins are installed properly, free from damage and locked in position.
Platform and platform attachment points	Be certain platform operates properly during lift functions without obstruction(s).
Inner rollstop	<ul style="list-style-type: none"> Be certain that inner rollstop operates properly during lift functions without obstruction(s). Be certain that inner rollstop deploys fully as platform stops at proper vehicle floor level.
Platform rollstop	Be certain that rollstop operates properly without obstructions when it contacts ground.
Hydraulic power unit	<div style="text-align: center;"> CAUTION</div> <p>Do not add fluid if platform is above ground level because reservoir will overflow when platform is lowered.</p> <ul style="list-style-type: none"> Check for visible hydraulic fluid leakage. Ensure backup pump manual release valve is lightly-snug.
SIX-MONTH SAFETY CHECK (or @ 1750 cycles of operation)	
Handrails	Be certain that all handrail fasteners are properly tightened.

TABLE 3-1: MAINTENANCE SCHEDULE	
SERVICE POINT	ACTION TO PERFORM
Cleaning and lubrication	<ol style="list-style-type: none"> 1. Clean lift with a mild soap and wipe dry. Rub down all surfaces with a light oil using a soft cloth to avoid rusting of material. Wipe clean any excess oil. 2. Following labeled directions on container, spray lubricant (Curtisol Red Grease No.88167 or WD-40), lubricate lift as specified in Lift Lubrication Points diagram. Wipe any excess grease from surrounding areas.
Hydraulic power unit	While platform is at GROUND LEVEL, be certain that pump hydraulic fluid level is maintained at required FULL level. Add only Texaco 01554 Aircraft Hydraulic Oil or equivalent U.S. mil spec H5606G fluid.
<p>CAUTION </p> <p>This safety check must be done by a ricon authorized dealer.</p>	
ANNUAL SAFETY CHECK (or @ 3500 cycles of operation)	
Hydraulic cylinder, hoses and fittings	<ul style="list-style-type: none"> • Check Hydraulic Cylinder for evidence of leaks. • Inspect hydraulic hoses for damage. • Be sure that all fittings are tightly secured.
END OF TABLE	

D. TROUBLESHOOTING

The troubleshooting guides are designed to provide logical starting points to locate general problems that could occur with lift. However, not all possible problems or combinations of problems are listed. For troubleshooting lift, refer to **Tables 3-2** and **3-3**. The guides do not incorporate routine safety precautions or preliminary procedures and assume that vehicle battery is fully charged and battery terminals/connectors are clean and tight.

 WARNING
<p>THE TROUBLESHOOTING GUIDES DO NOT INCORPORATE ROUTINE SAFETY PRECAUTIONS OR PRELIMINARY PROCEDURES. DURING THE RICON WARRANTY PERIOD A RICON AUTHORIZED DEALER MUST PERFORM TROUBLESHOOTING. AFTER THE WARRANTY PERIOD, IT IS RECOMMENDED THAT TROUBLESHOOTING BE CONTINUED BY A RICON AUTHORIZED DEALER OR QUALIFIED SERVICE TECHNICIAN.</p>

1. INTERLOCK INDICATOR DIAGNOSTICS

The purpose of a vehicle interlock system is to prevent operation of lift if an unsafe condition is present. When vehicle interlock systems are interfaced with lift circuitry, the interlock indicator shows whether or not interlock is operating properly. The light is interfaced with electrical system so that no matter which interlock system/method is used, the light will be ON when interlock allows electrical power to lift and OFF when interlock has disabled power to lift. When there is no interlock system installed, the light stays illuminated at all times.

A light-assembly is installed in the position where door operator circuit breaker would normally be mounted on all lift assemblies **without** optional door operator. The light indicates power is supplied to signal portion of electrical system, and will aid in diagnosing electrical problems.

TABLE 3-2: INTERLOCK INDICATOR TROUBLESHOOTING GUIDE	
SYMPTOM	POSSIBLE CAUSE
Light is not lit, lift does not operate.	Control system circuit breaker is tripped. Interlock system is not allowing power to lift due to an unsafe condition or a faulty interlock.
Light is not lit, lift operates.	Light needs to be replaced.
Light is lit, lift works in an unsafe condition.	Interlock is not functioning.
Light is lit, lift does not operate.	There is a problem with electrical system, either with power or signal side. Both will have to be checked, but start with power side since it is less complicated.
END OF TABLE	

2. PUMP SOLENOID LED STATUS INDICATOR

Refer to **Figure 3-2**. In April 2000 a second pump solenoid was installed next to the original pump solenoid. Two solenoids provide a margin of safety if one of the solenoids fails with its contacts closed. A status indicator LED is located between the 8A and 30A circuit breakers to monitor the condition of the two solenoids. The LED is normally off when the pump is not operating and becomes green when the pump operates. When the pump is not operating and the top solenoid has failed the LED will be red. The LED will be green when the side solenoid has failed.

A retrofit kit is available to add the second pump solenoid to lifts that have only a single solenoid. It is Ricon p/n 19068.

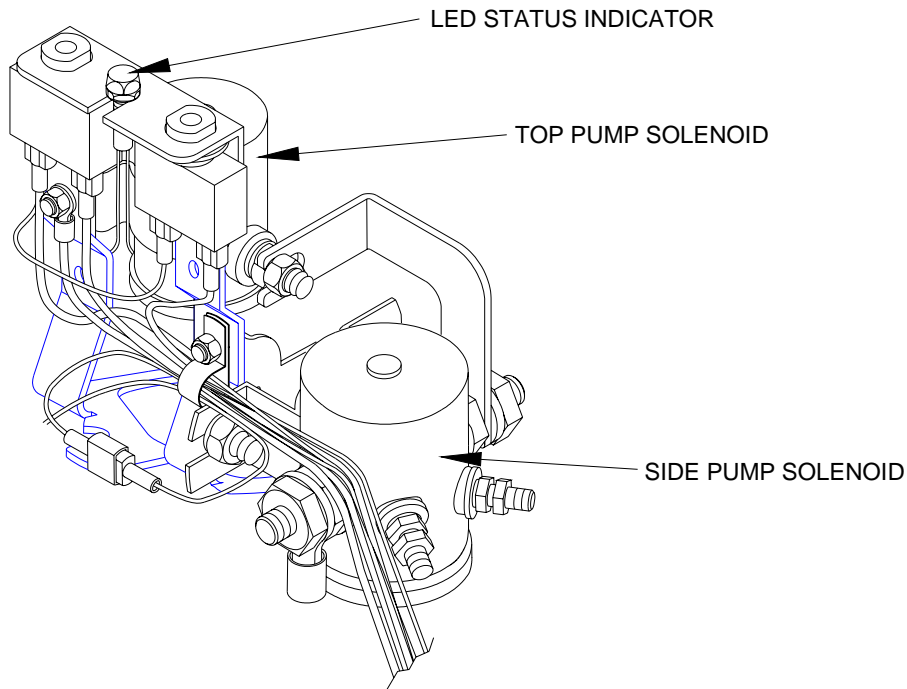

FIGURE 3-2: STATUS INDICATORS FOR PUMP SOLENOIDS

3. LIFT TROUBLESHOOTING

TABLE 3-3: LIFT OPERATIONAL TROUBLESHOOTING GUIDE			
SYMPTOM	POSSIBLE CAUSE	REMEDY	
Hydraulic fluid leaks	Loose hydraulic fitting.	Make sure fitting is PROPERLY tightened.	
	Hydraulic component defective.	Discontinue use of lift until repairs are made by an authorized Ricon dealer or qualified service technician.	
Rollstop does not open	Obstruction of rollstop release latch.	Raise lift and remove obstruction.	
Lift functions	Abnormal Operation.	Obstruction in lifting frame.	Remove obstruction and check for any damage
		Backup pump manual release valve OPEN.	Turn manual release valve CLOCKWISE until lightly-snug.
		Hydraulic fluid may be low.	While platform is at GROUND LEVEL, be sure that the pump hydraulic fluid level is maintained at required FULL level. Add only Texaco 01554 Aircraft Hydraulic Oil or equivalent U.S. mil spec H5606G fluid.
		Air may be trapped in hydraulic system.	Purge hydraulic system by operating lift through its maximum range of travel for at least four complete cycles. (For vehicles that do not use the full travel of the lift, the maximum range of travel is accomplished by raising vehicle on a service hoist or ramp.)
	No Operation.	Control System Circuit Breaker tripped.	Reset circuit breaker.
		Backup pump manual release valve OPEN.	Turn manual release valve CLOCKWISE until lightly-snug.
		Hydraulic hose or fitting leak.	Contact an authorized Ricon dealer or qualified service technician for repair.
		Hydraulic fluid may be low.	While platform is at GROUND LEVEL, ensure that pump hydraulic fluid level is maintained at required FULL level. Add only Texaco 01554 Aircraft Hydraulic Oil or equivalent U.S. mil spec H5606G fluid.
		Air may be trapped in hydraulic system.	Purge hydraulic system by operating lift through its maximum range of travel for at least four complete cycles. (For vehicles that do not use the full travel of the lift, the maximum range of travel is accomplished by raising vehicle on a service hoist or ramp.)
END OF TABLE			

E. HYDRAULIC CIRCUIT DIAGRAM

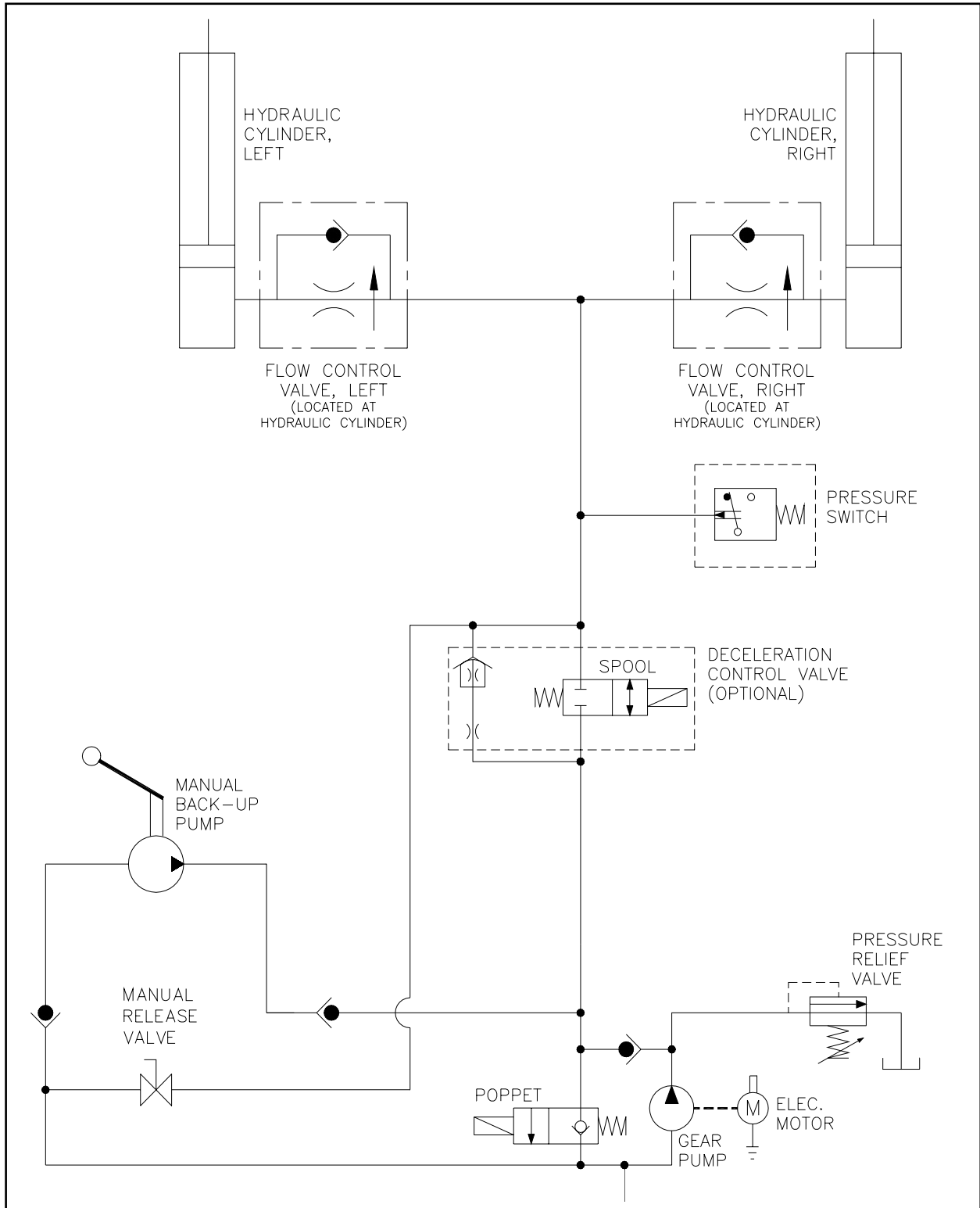

FIGURE 3-3: S-SERIES HYDRAULIC CIRCUIT DIAGRAM

F. ELECTRICAL WIRING DIAGRAM

1. DIAGRAM LEGENDS

a. Wire Color Codes

TABLE 3-4: WIRE COLOR CODES			
LETTER	COLOR	LETTER	COLOR
BK	Black	R	Red
BL	Blue	VI	Violet
BR	Brown	GY	Gray
GN	Green	W	White
O	Orange	Y	Yellow
END OF TABLE			

I. Electrical Connector Description

Refer to **Figure 3-4**. The standard electrical connectors used by Ricon are Molex .062" Series. These connectors have terminal numbers molded onto the rear; use these numbers to identify wires.

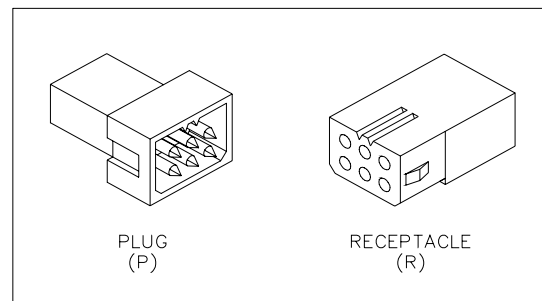

FIGURE 3-4: MOLEX CONNECTORS

II. Diagram Labels

12V	12 Volts – Circuit current rating is also given
DC	Door Close – Direct command
DO	Door Open – Direct command
DOE	Door open Enable – From Door Open cutoff switch
DWN	Pump Down – Used by OUT and DWN
DWNA	Down Attempt – Must be enabled
FAST	Signal to speedup valve for UP and DOWN
GND	GROUND
OUTA	Out Attempt – Out must be enabled
SDA	System Deploy Attempt – DO followed by OUT
SSA	System Store Attempt – IN followed by DC
UP	Pump Up – Used by UP and IN
UPA	Up Attempt – Up must be enabled

III. Electrical Symbols

Figure 3-5 defines symbols used in the electrical wiring diagrams.

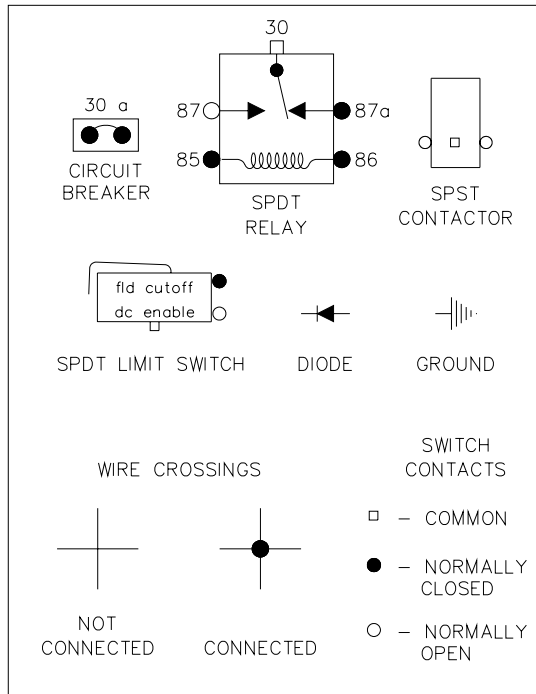

FIGURE 3-5: DIAGRAM SYMBOLS

2. LIMIT SWITCH DIAGRAM

Refer to **Figure 3-6**. The actuation diagram shows the state of all limit switches as the platform travels from stowed, to vehicle floor level, and then to ground level. The solid line segments represent current flow through the normally CLOSED switch contacts, and the open line segments represent current flow through the normally OPEN switch contacts. The heavy dashed lines show switch states when platform is beyond normal travel boundaries. This is useful in showing the operation of switches that change states at stowed or ground level positions. For proper operation of lift, the switch actuations must overlap as shown.

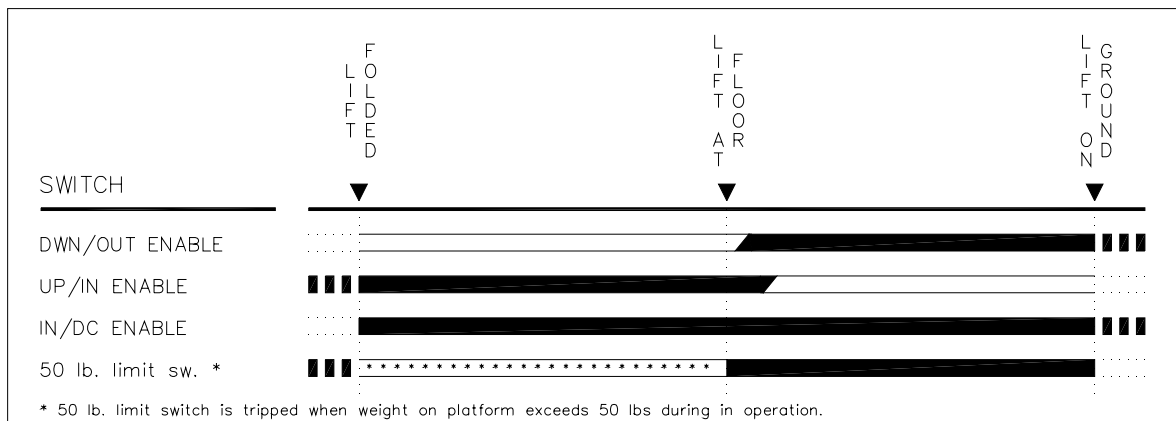
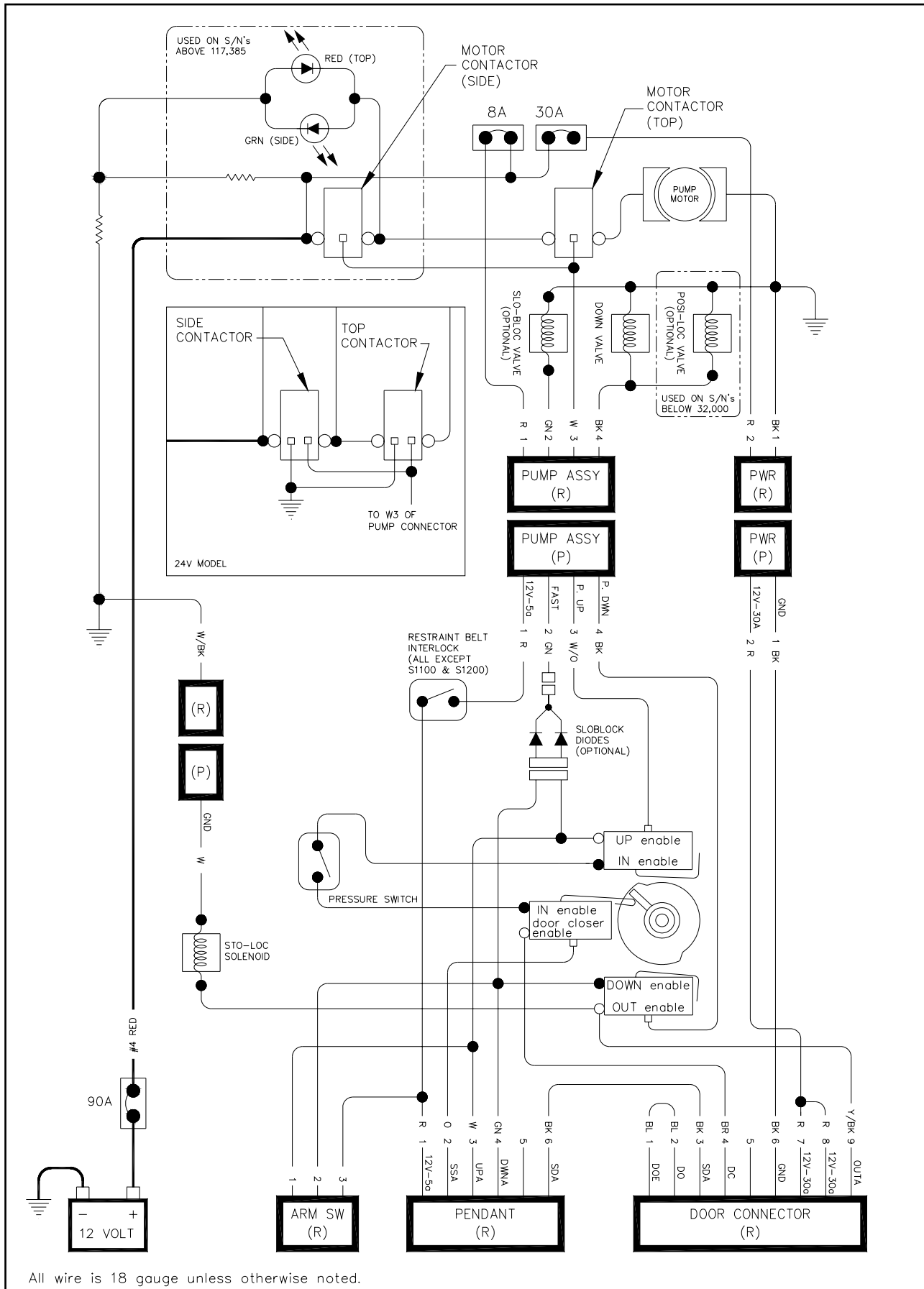

FIGURE 3-6: LIMIT SWITCH ACTUATION

3. WIRING DIAGRAMS



All wire is 18 gauge unless otherwise noted.

FIGURE 3-7: WIRING DIAGRAM WITH DOOR OPERATOR

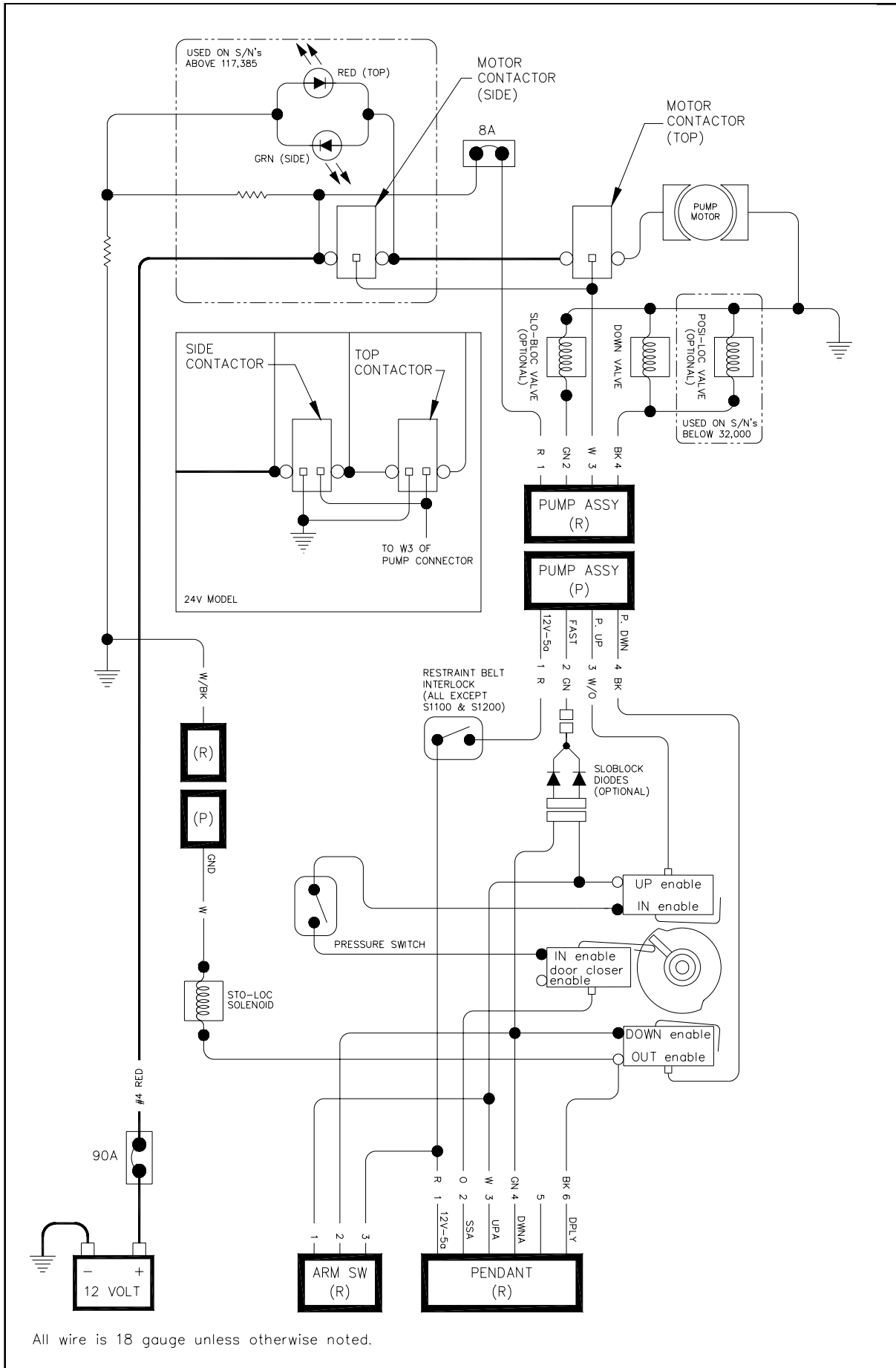

All wire is 18 gauge unless otherwise noted.

FIGURE 3-8: WIRING DIAGRAM WITHOUT DOOR OPERATOR

This page intentionally left blank.

IV. S-SERIES EXPORT PARTS DIAGRAMS AND LISTS

This chapter contains parts diagrams and parts lists for the RICON S-Series Export Use Wheelchair and Standee Lift with Folding Platform. The exploded view of each major lift assembly shows individual components referenced by numbers. On each associated parts list is the reference number, a part description, the quantity used and the Ricon part number. For part numbers of lift decals, refer to the “Decal Locations and Part Numbers” figure in Chapter II of this manual.

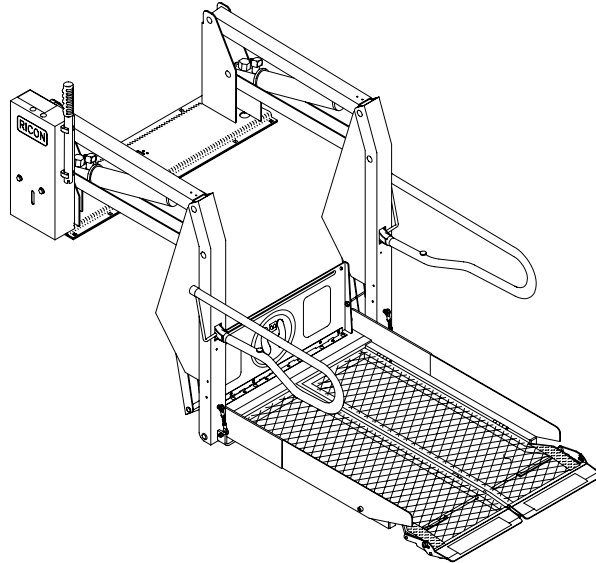

NOTE: To order a part: locate the part or assembly on an exploded view, note its reference number, find this number on the associated parts list (following page), and order the part number in the far right column. Most kits contain a single part (plus hardware). Therefore, you may need to order more than one kit if the part is used more than once on a major assembly.

NOTE: Some major lift components that are typically painted gray may also be available in other colors, such as red, yellow, and blue. These include the platform assembly, handrails, vertical arms, top and bottom arms, and baseplate assembly.

LIFT MODEL AND KIT NUMBERS	
PRODUCT NUMBER	S2030-E1000000 (first model in number sequence)
DOCUMENTATION KIT NUMBER	01074
PRODUCTION DECAL SET NUMBER	SXXXXLEXXXXXXXX
SPARE DECAL KIT NUMBER	26013

PARTS DIAGRAM PAGE

FIGURE 4-1: MONARCH HYDRAULIC POWER UNIT #14-2

FIGURE 4-2: S-SERIES HYDRAULIC SYSTEM4-6

FIGURE 4-3: S-SERIES ELECTRICAL SYSTEM4-8

FIGURE 4-4: S-SERIES PENDANT4-10

FIGURE 4-5: S-SERIES SPLIT PLATFORM4-12

FIGURE 4-6: S-SERIES TRAVELING FRAME4-16

FIGURE 4-7: S-SERIES STANDEE HANDRAIL (EXPORT)4-20

LIFT SPECIFICATIONS4-23

DATE: 05/05/04
DWG. SSX00001
REV K

MONARCH HYDRAULIC POWER UNIT #1
SERIAL NO's. 31000-31999
SERIAL NO's. 35000 - PRESENT

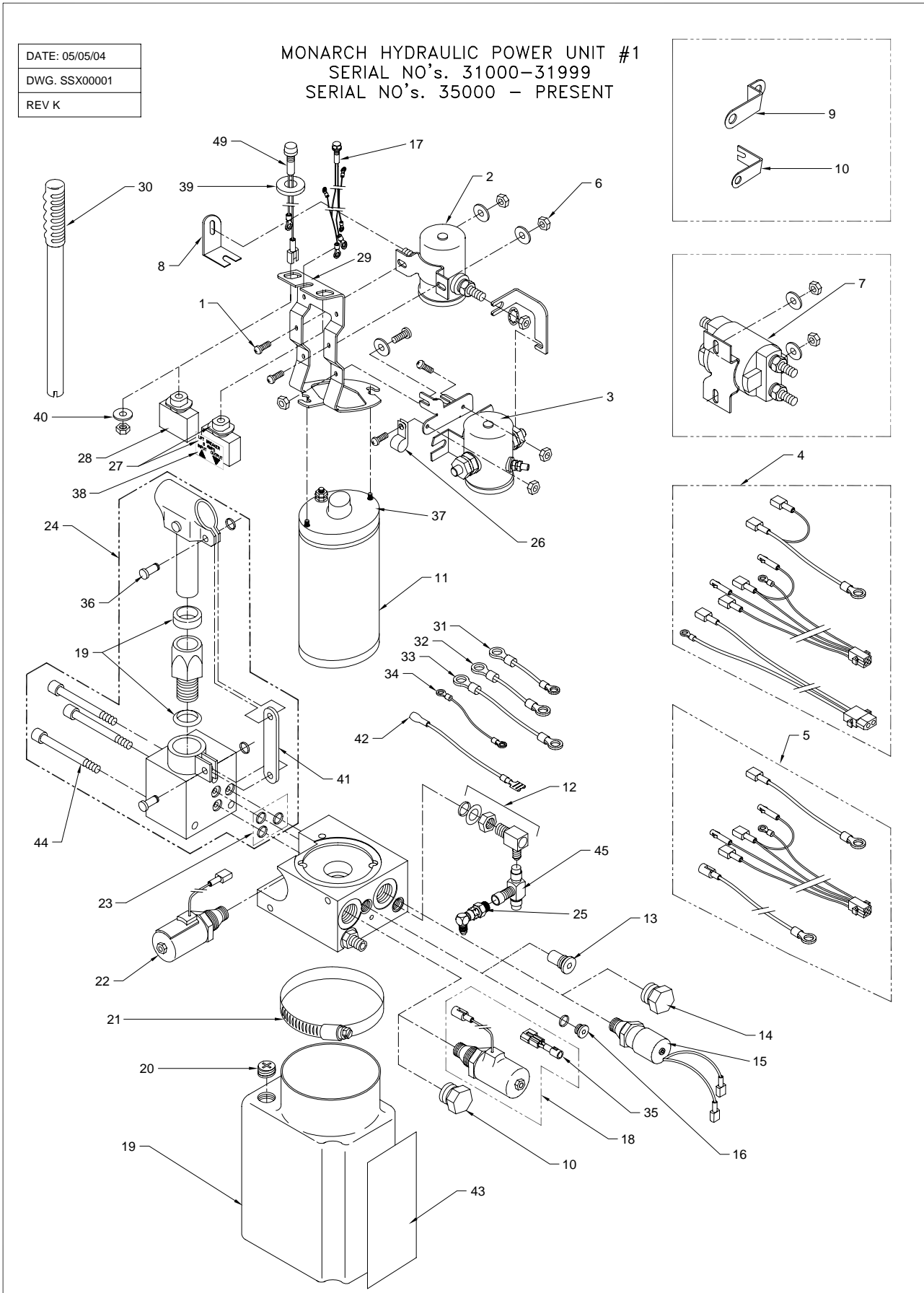

FIGURE 4-1: MONARCH HYDRAULIC POWER UNIT

**FIGURE 4-1: MONARCH HYDRAULIC POWER UNIT #1
S-SERIES (ALL MODELS) WHEELCHAIR LIFT
SERIAL NO's. 31000 - 31999
SERIAL NO's. 35000 - PRESENT**

REF.	DESCRIPTION	QTY.	PART NO.
1	SCREW,10-24 X ½ PAN HEAD, SELF THREAD	3	28111T
2	SOLENOID, SPST, 12V	1	20668
3	SOLENOID, SPST, 24V	1	26449
4	HARNESS, PUMP, w/DOOR INTERLOCK, (S/N's 32000-95999)	1	V2-ES-100
	HARNESS, PUMP, w/DOOR INTERLOCK, (SN 96000 - present)	1	10069
5	HARNESS, PUMP, w/o DOOR INTERLOCK, (S/N's 32000-95999)	1	V2-ES-150
	HARNESS, PUMP, w/o DOOR INTERLOCK, (SN 96000 - present)	1	10335
6	NUT, NYLON INSERT, 10-24, (BAG OF 10)	3	13382
7	KIT,SOLENOID,12V,DBL POLE,w/HDWR	1	20670
	KIT,SOLENOID,24V,DBL POLE,w/HDWR	1	20669
8	BUS BAR, MOTOR, SP SOLENOID, (S/N's 52456-95999) (DISCONTINUED)	1	V2-ES-034
	BUS BAR (SN 96000 - present)	1	10807
9	BUS BAR, MOTOR, DP SOLENOID, (S/N's 32000-95999) (DISCONTINUED)	1	UV-ES-040
10	BUS BAR (SN 96000 - present)	1	13087
11-1	MOTOR ASSY, 12V, 3", MONARCH PUMP (P/N V2-SH-115 DISCONTINUED)	1	14345
11-2	MOTOR ASSY, 24V, 3", MONARCH PUMP (P/N V2-ES-116 DISCONTINUED)	1	14346
11-3	MOTOR ASSY, 12V ISKRA (SN 96000 - present) (DISCONTINUED)	1	14332
	MOTOR ASSY, w/BRACKET, 12V ISKRA	1	14345
11-4	MOTOR ASSY, 24V ISKRA (SN 96000 - present) (DISCONTINUED)	1	14333
	MOTOR ASSY, w/BRACKET, 24V ISKRA	1	14346
12	FITTING ASSY, ELBOW, #4 STD THD X #4 JIC, w/HDWR	1	18235
13	DECELERATION VALVE ASSY	1	V2-SH-279
14	PLUG, 3/4-16 CAVITY, w/O-RING (DISCONTINUED)	2	V2-SH-001
15	KIT, PRESSURE SWITCH, W/INSTRUCTIONS (P/N 16640 SUPERSEDED)	1	42050
16	PLUG w/O-RING	1	V2-SH-182
17	LIGHT ASSY, INDICATOR, 12V (P/N 15207 DISCONTINUED)	1	19067
18-1	SPOOL VALVE ASSY, 12V, ADA APPLICATIONS	1	01176
18-2	SPOOL VALVE ASSY, 24V, ADA APPLICATIONS	1	01177
19	RESERVOIR, PUMP, PLASTIC w/DECAL & PLUG	1	30938
20	PLUG, BREATHER, RESERVOIR,	1	V2-SH-106
21	HOSE CLAMP	1	V2-SH-109
22-1	VALVE ASSY, POPPET, DELTROL, 12V	1	V2-SH-105
22-2	VALVE ASSY, POPPET, DELTROL, 24V (DISCONTINUED)	1	V2-SH-136
23	SEAL KIT, MANUAL BACK-UP PUMP	1	V2-SH-220
24	BACK-UP PUMP, MANUAL (S/Ns 6000-30,999 & 32,000-31,999)	1	V2-SH-110
24-1**	BACK-UP PUMP, MANUAL (S/Ns 31,000-31,999 & 35,000-present)	1	V2-SH-210
25	FITTING ASSY, SNL, 1/4J X 1/4J, STEEL	1	VS-SH-06
26-1	CABLE CLAMP, 3/8", NYLON, (BAG OF 10)	1	18660
26-2	CABLE CLAMP, 3/16", NYLON, (BAG OF 10)	1	19798
26-3	CABLE CLAMP, 5/16", NYLON, (BAG OF 10)	1	19772
26-4	CABLE CLAMP, ½", NYLON, (BAG OF 10)	1	19774
27	CIRCUIT BREAKER, 8 AMP, w/HDWR & DECAL	1	V2-SH-005
28	CIRCUIT BREAKER, 30 AMP, w/HDWR	1	26510
29-1	BRACKET, SOLENOID MOUNTING (S/N's 32000-95999)	1	V2-SH-127
29-2	BRACKET, SOLENOID ISKRA (S/N 96000-)	1	10507
30	HANDLE, MANUAL BACK-UP PUMP	1	V2-SH-111
31	JUMPER, DPDT SOLENOID, BLK, 10GA, 5.0"	1	ELJ00121
32	JUMPER, DPDT SOLENOID w/ISOLATED GROUND, BLK, 10GA, 5.5"	1	ELJ00122
33	JUMPER, DPDT SOLENOID, RED, 10GA, 5.5"	1	ELJ02055
34	JUMPER, DPDT SOLENOID, ORG, 18GA, 5.0"	1	ELJ03061
35	DIODE BLOCK ASSEMBLY	1	08232
36	PIN & RETAINING RING	2	V2-SH-017
37-1	KIT, PUMP MOTOR BRUSH SET (inside motor) (S/N's 32000-95999) (DISCONTINUED)	1	V2-SH-115B
37-2	KIT, PUMP MOTOR BRUSH SET (located inside motor) (S/N 96000 - present)	1	14334
38	DECAL, 8 AMP CIRCUIT BREAKER (DISCONTINUED)	1	26290
39	ADAPTER, .625 D-HOLE TO .484 ROUND	1	V2-ES-059
40	WASHER, FLAT, 7/16 (S/N's 61878 - present) (BAG OF 10)	1	19716

REF.	DESCRIPTION	QTY.	PART NO.
41	BRACKET, TENSION LINK, MONARCH PUMP	1	V2-SH-149
42-1	JUMPER, SWITCH, PRESSURE, RH PUMP	1	15860
42-2	JUMPER, SWITCH, PRESSURE, LH PUMP	1	19091
43	DECAL, OIL LEVEL WARNING	1	32-10-154
44	SCREW, SHC, 1/4-20X2.5 (BAG OF 10)	3	32407
45	FITTING, SRT, 1/4J, STEEL	1	V2-SH-012
46**	KIT, RETROFIT, 2nd SOLENOID, 12V	1	19068
47**	KIT, RETROFIT, 2nd SOLENOID, 24V	1	19843
48**	HARNESS, EXT, RH PUMP	1	V2-ES-155
49-1	LIGHT, LIFT ARMED INDICATOR, 12V (S/N's 61878 - present)	1	UL-ES-034
49-2	LIGHT, LIFT ARMED INDICATOR, 24V (S/N's 61878 - present)	1	V2-ES-016

** Item not shown.

This page intentionally left blank.

S-SERIES HYDRAULIC SYSTEM
SERIAL NO's. 32000 - PRESENT

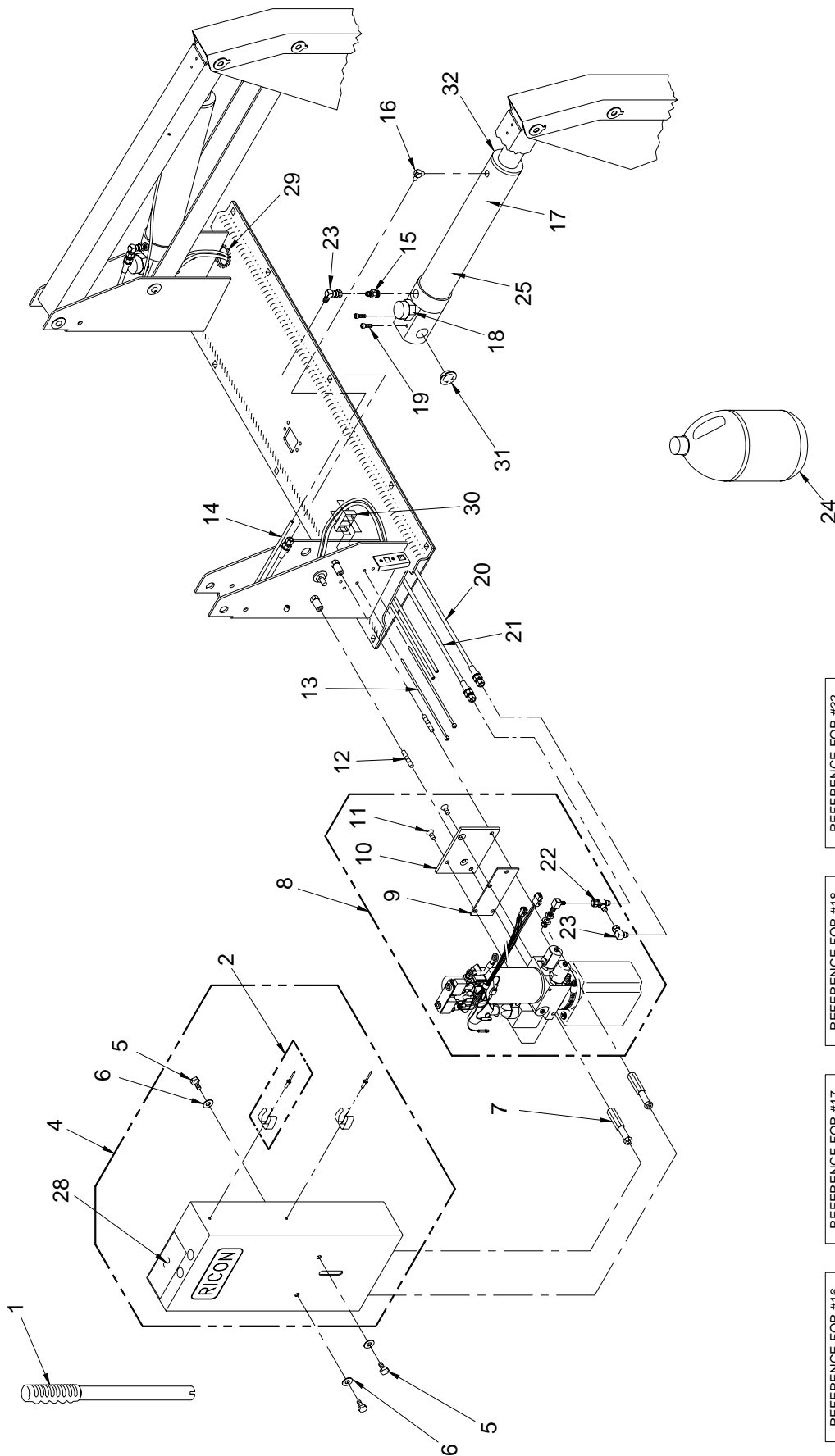

REFERENCE FOR #16		"L" FITTING, MALE, 10-32 X 1/4 BARB
REFERENCE FOR #17		REBUILD KIT, HYDRAULIC CYLINDER
REFERENCE FOR #18		FLOW CONTROL, PRESSURE COMPENSATED, FIXED RATE
REFERENCE FOR #32		GLAND NUT, 1.50", WITH SEAL

FIGURE 4-2: S-SERIES HYDRAULIC SYSTEM

**FIGURE 4-2: S-SERIES HYDRAULIC SYSTEM
(ALL MODELS) WHEELCHAIR LIFT
SERIAL NO's. 32000 – PRESENT**

REF.	DESCRIPTION	QTY.	PART NO.
1	HANDLE, MANUAL BACKUP PUMP	1	V2-SH-111
2	KIT, TOOL CLIP, W/HDWR	2	19557
4-1	COVER, PUMP, RH (S/N's 31000-31999 & 35000- present)	1	V2-CV-221
4-2	COVER, PUMP, LH (S/N's 31000-31999 & 35000-present)	1	V2-CV-220
4-3	COVER, PUMP, LH (S/N's 6000-31000) (DISCONTINUED)	1	V2-CV-021
5	SCREW, HEX HEAD, 5/16-18 X .625 (BAG OF 10)	3	14495
6	WASHER, FLAT, 5/16", SAE (BAG OF 10)	1	13350
7	HEX ROD, PUMP STANDOFF	2	V2-CV-015
8-1	S-SERIES PUMP, 12V, NOTOP, UV RES, 2KPSI	1	PM212002007
8-2	S-SERIES PUMP, 12V, w/INTLK & ANTIDRIFT (DISCONTINUED)	1	PM212090110
8-3	S-SERIES PUMP, 12V, w/COMMON BRACKET (s/n's 31000 - 31999 & 35000 - present)	1	PM212090100
8-4	S-SERIES PUMP, 24V, w/COMMON BRACKET (s/n's 31000 - 31999 & 35000 - present)	1	PM224110100
8-5	S-SERIES PUMP, 12V, w/COMMON BRACKET (s/n's 32000 - 34999)	1	PM212090100
8-6	S-SERIES PUMP, 24V, w/COMMON BRACKET (s/n's 32000 - 34999)	1	PM224110100
8-7	S-SERIES PUMP, 12V, COM BRKT, w/o INTLK, RH, DCL	1	PM212090308
8-8	S-SERIES PUMP, 24V, COM BRKT, w/o INTLK, RH, DCL	1	PM224100108
9	PLATE, PUMP COVER MOUNT	1	V2-AC-71
10	PLATE, PUMP MOUNTING	1	V2-AC-70
11	SCREW, FLAT HEAD, 5/16-18 X 3/4" (BAG OF 10)	2	14499
12	STUD, THREADED, 5/16-18 X 1.75" (BAG OF 10)	2	14500
13	CABLE TIE, 5.5", BLACK (BAG OF 10)	2	25697
14	TUBE, POLYURETHANE, 6MM x 4MM, BLACK	9'	22-02-230
15-1	ADAPTOR, STRAIGHT, 1/4 NPT MALE (S/N's 32000-63999)	2	V2-SH-84
15-2	ADAPTOR, # 6 SAE MALE X # 4 JIC MALE (S/N's 64000 - present)	2	26591
16	FITTING, "L", MALE 10-32 X 1/4 BARB	2	V2-SH-16
17	KIT, CYLINDER REPAIR, W-PISTON ASSY, GLAND NUT AND SEAL	2	21829
18	KIT, FLOW CONTROL, PRESSURE COMPENSATED, FIXED RATE (KIT OF 2)	2	30968
19	SCREW, HEX HEAD, 1/4-20 X 1, BAG OF 10	4	14491
20	HOSE ASSY, 61" X 1/4 JIC X 1/4 JIC	1	V2-SH-009
21	HOSE ASSY, 26" X 1/4 JIC X 1/4 JIC	1	V2-SH-008
22	FITTING, RUN TEE, 1/4 JIC M-M-F	1	V2-SH-012
23	FITTING, "L", 1/4 JIC M-F SWIVEL	3	VS-SH-06
24	OIL, HYDRAULIC, TEXACO #15, MEETS MIL-H-5606G	1 GAL	20-16-051
25-1	CYLINDER ASSY, S-1200	2	VS-SH-105
25-2	CYLINDER ASSY, S-2000	2	VT-SH-105
25-3	CYLINDER ASSY, S-5000	2	V5-SH-105
28	DECAL, MANUAL OPERATION (TOP, w/CB)	1	26214
29	GROMMET, CATERPILLAR, 3/16"	8.5"	26647
30	SPACER, CABLE AND HOSE	2	25557
31	BUSHING, 3/4"ID X 3/8W	4	25381
32	GLAND NUT AND SEAL (SUPERSEDED)	2	21829

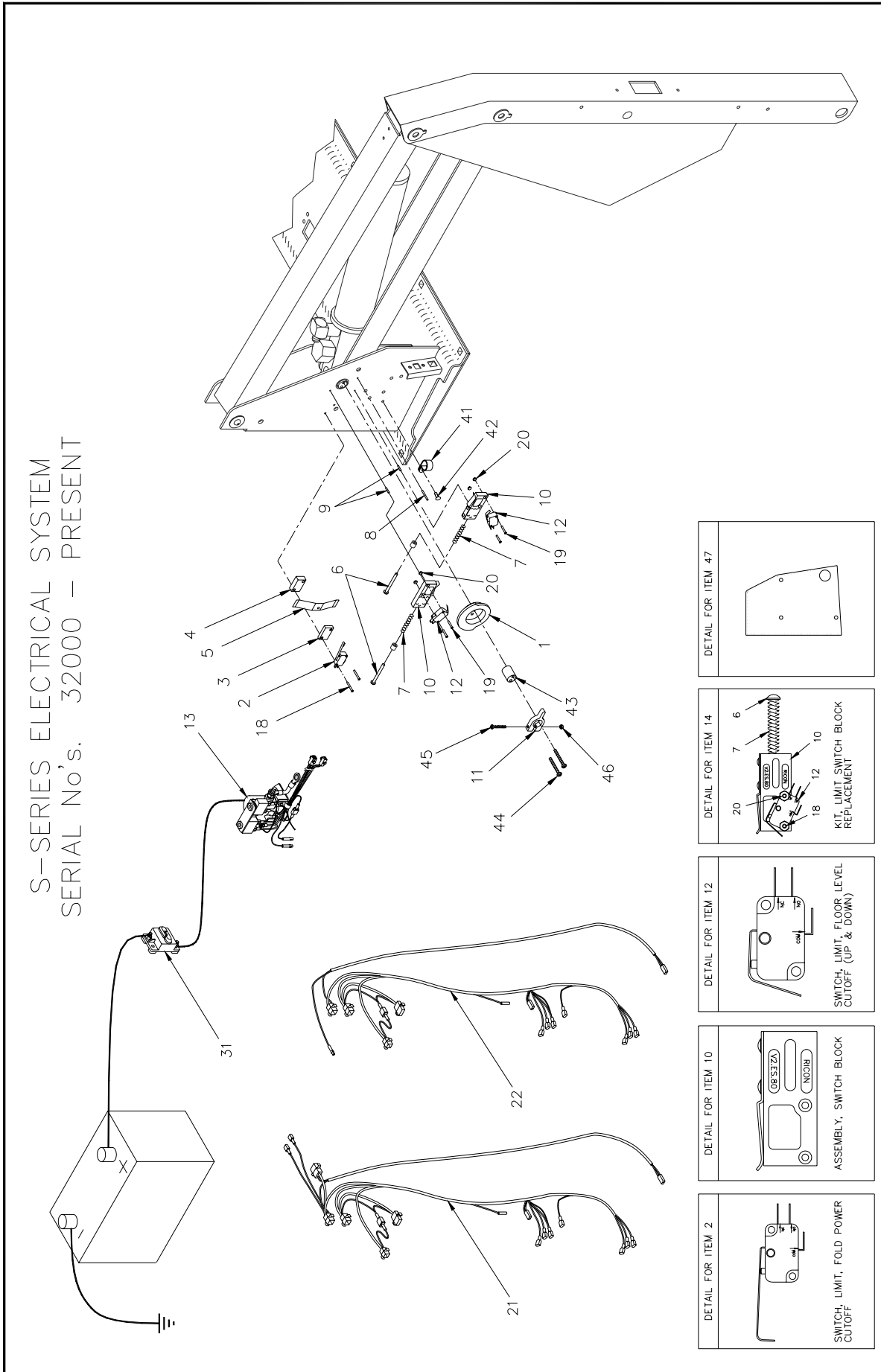

FIGURE 4-3: S-SERIES ELECTRICAL SYSTEM

**FIGURE 4-3: S-SERIES ELECTRICAL SYSTEM
(ALL MODELS) SERIAL NO's. 32000 - PRESENT**

REF.	DESCRIPTION	QTY.	PART NO.
1-1	CAM, LIFT CONTROL w/SET SCREW (S/N's 32000-62559)	1	V2-ES-99
1-2	CAM, LIFT CONTROL (S/N's 62560 - present)	1	V2-AC-107
2	SWITCH, LIMIT, FOLD POWER CUTOFF	1	V2-ES-111
3	BLOCK, FOLD CUTOFF SWITCH OFFSET, 1/4" THICK	1	V2-ES-78
4	BLOCK, FOLD CUTOFF SWITCH OFFSET, 3/8" THICK	1	V2-ES-79
5	SPRING, RETAINING, UPPER/LOWER SWITCH BLOCK	1	V2-ES-95
6	SCREW, ROUND HEAD, 10-24 X 2" (ADJUSTING) (BAG OF 10)	2	14497
7	SPRING, COMPRESSION, .30 OD X 2.06L	2	V2-ES-93
8	ROLL PIN, .94 X 1 (TIMING PIN) (BAG OF 10)	1	14498
9	ROLL PIN, .94 X .50 (SWITCH BLOCK MOUNT) (BAG OF 10)	2	14496
10	SWITCH BLOCK ASSY, (UPPER & LOWER)	2	34314
11-1	KIT, RETRO, CAM (S/N's 32000-62559 P/N V2-BU-89 DISCONTINUED)	1	01287
11-2	ACTUATOR, FOLD CUTOFF (S/N's 62560 - present)	1	V2-AC-089
12	SWITCH, LIMIT, FLOOR LEVEL POWER CUTOFF (UP & DOWN)	2	V2-ES-110
13	COMPONENTS, SOLENOID BRACKET (for replacement parts, refer to hydraulic power unit parts list drawing	—	—
14	KIT, LIMIT SWITCH BLOCK REPLACEMENT	2	V2-ES-61
18	SCREW, 4-40 X 1.25 PAN HEAD (BAG OF 10)	2	15908
19	SCREW, 4-40 X .75 PAN HEAD (BAG OF 10)	4	15909
20	NUT, HEX, 4-40 (BAG OF 10)	4	15903
21	ELECTRICAL HARNESS, MAIN, w/DOOR OPERATOR INTERCONNECT	1	V2-ES-051
22	ELECTRICAL HARNESS, MAIN, w/o DOOR OPERATOR INTERCONNECT	1	V2-ES-050
31	CIRCUIT BREAKER, MAIN	1	01010K
41	CLAMP, CABLE, 11/16" (S/N's 53168 - present)	1	255161
42	MS, 10-24 X 1/2 PHIL PAN (BAG OF 10)	1	13304
43	PIN, EXTENSION FOLD CUTOFF (S/N's 62560 - present) (BAG OF 10)	1	15914
44	MS 10-24 X 1 3/4 PHIL PAN (S/N's 62560 - present) (BAG OF 10)	2	15915
45	MS 8-32 X 1 1/4 PHIL PAN (S/N's 62560 - present) (BAG OF 10)	1	15906
46	NUT-HEX 8-32 NYLON INSERT (S/N's 62560 - present) (BAG OF 10)	1	15907
47 *	COVER, ELEC SYSTEM	1	V2-CV-110

* Used for left hand installation only.

S-SERIES PENDANT

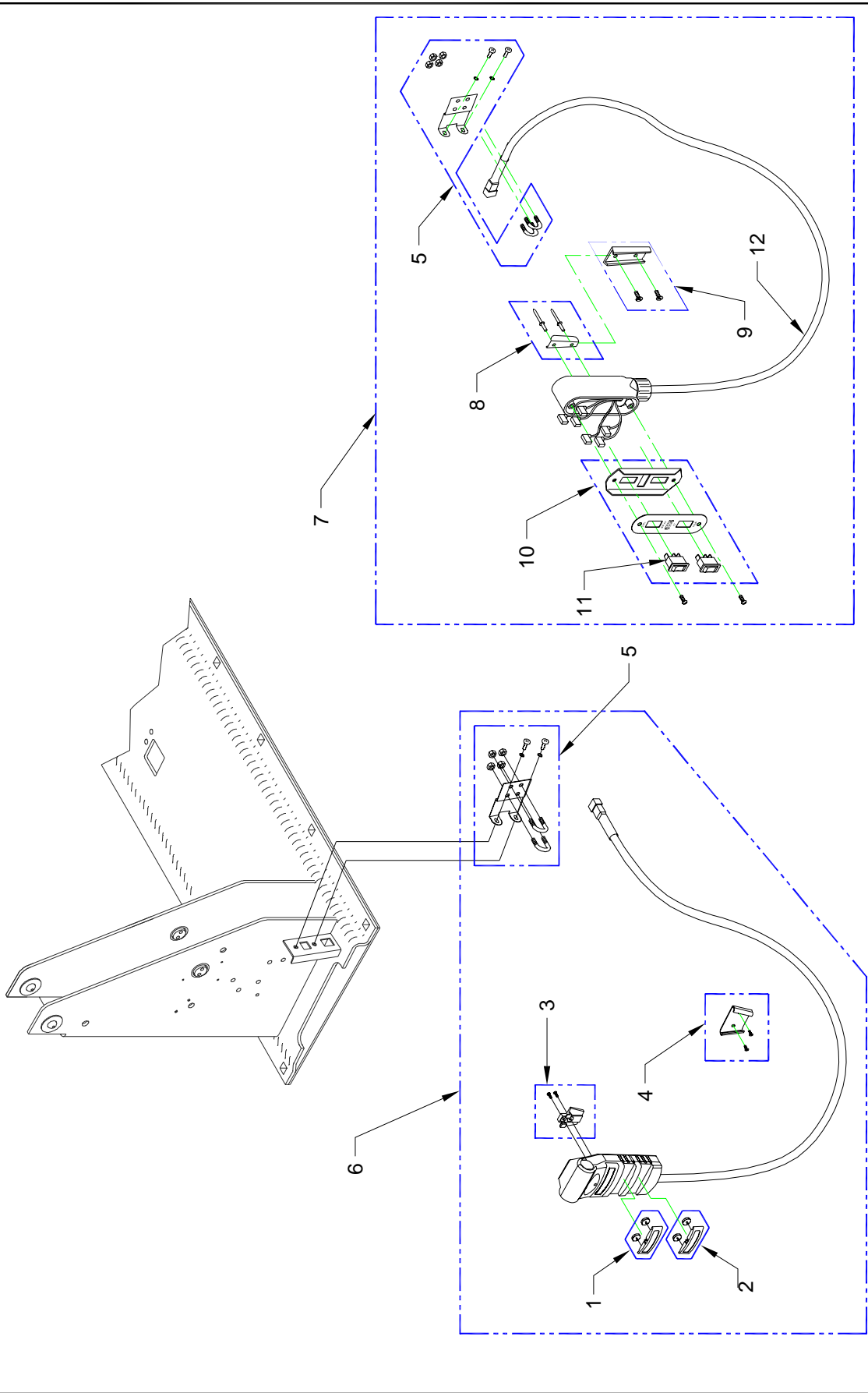

FIGURE 4-4: S-SERIES PENDANT

FIGURE 4-4: S-SERIES PENDANT

REF.	DESCRIPTION	QTY.	PART NO.
1	SPARE PARTS, STOW/DEPLOY BUTTON, S-SERIES	1	14731
2	SPARE PARTS, UP/DOWN BUTTON, S-SERIES	1	14732
3	SPARE PARTS, V-BRACKET, PLASTIC	1	14733
4	KIT, WALL MOUNT BRACKET, UNIVERSAL PENDANT	1	14709
5	KIT, CONTROL HARNESS STRAIN RELIEF, S-SERIES	1	01007
6-1	KIT, PENDANT, S-SERIES, 7 FT	1	14727
6-2	KIT, PENDANT, S-SERIES, COILED CORD	1	14728
6-3	KIT, PENDANT, S-SERIES, 10 FT	1	14729
6-4	KIT, PENDANT, S-SERIES, STEEL JACKETED CORD	1	14730
7	KIT, PENDANT, OLD-STYLE (W/ROCKER SWITCH)	1	01008
8	KIT, CLIP, PENDANT, MALE W/RIVETS	1	28781
9	KIT, INSTL, PENDANT MTG CLIP	1	01118
10	FACEPLATE ASSY, PENDANT, SWITCH GD	1	V2-ES-035
11	SWITCH, SP ROCKER, ON-OFF-ON BLK	2	26455
12	HARNESS REPLACEMENT, 7FT CORD (FOR 01008 ONLY-OLD STYLE PENDANT)	1	V2-ES-024

DATE: 06/01/04
DWG: SSX00006

S-SERIES SPLIT PLATFORM
SERIAL NO's. 32000 -

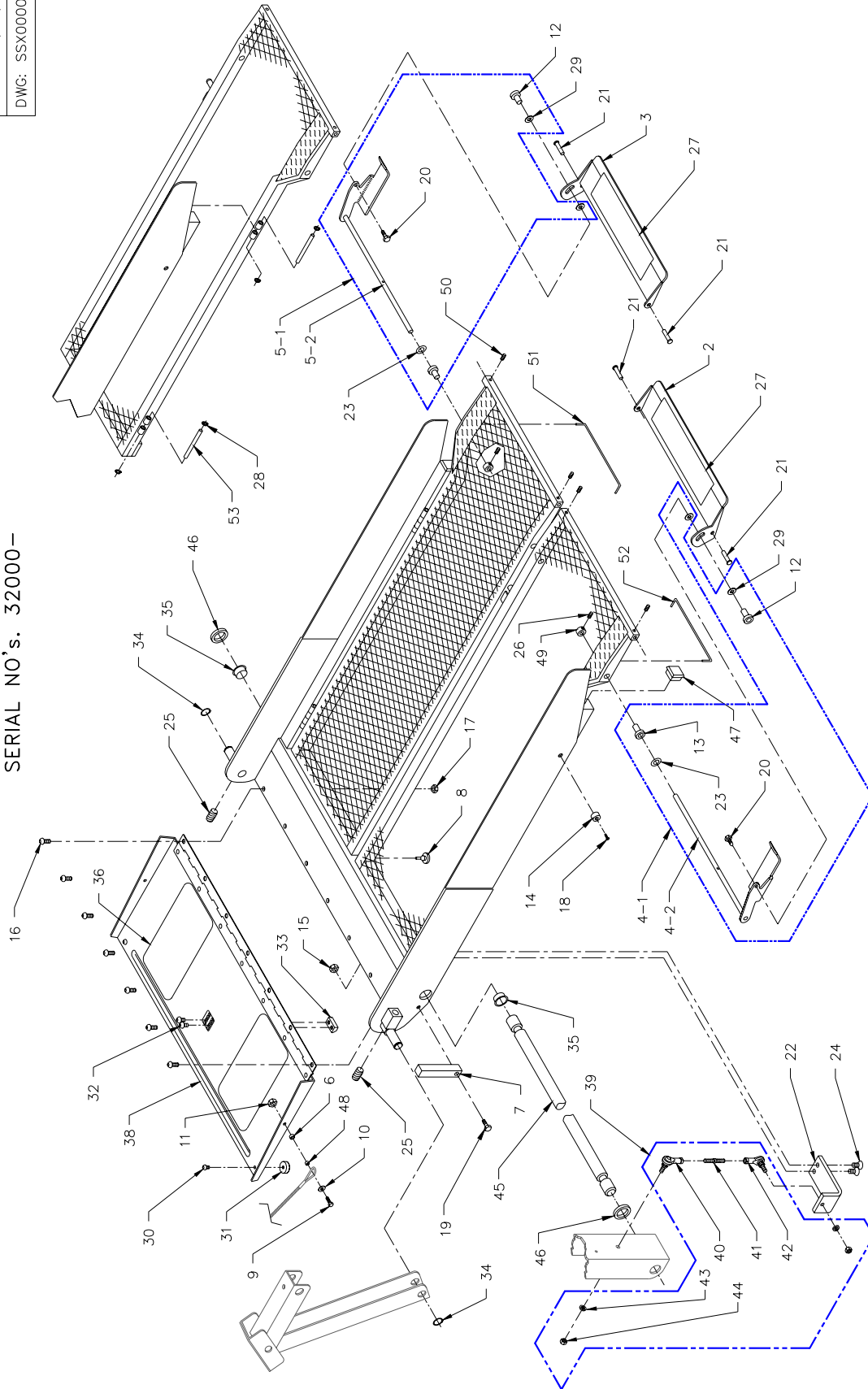

FIGURE 4-5: S-SERIES SPLIT PLATFORM

**FIGURE 4-5: S-SERIES SPLIT PLATFORM
EXPORT WHEELCHAIR LIFT (SERIAL NO'S. 32000 – PRESENT)**

REF.	DESCRIPTION	QTY.	PART NO.
1-1*	PLATFORM ASSY, SPLIT, 30 X 42	1	V2-PF-380
1-2 *	PLATFORM ASSY, SPLIT, 30 X 48	1	V2-PF-381
1-3 *	PLATFORM ASSY, SPLIT, 26 X 38, S1100	1	V1-PF-380
1-4 *	PLATFORM ASSY, SPLIT, 30 X 38, S1100	1	V1-PF-381
2-1	ROLLSTOP ASSY, LH, SPLIT PLATFORM, 30"	1	V2-PF-122
2-2	ROLLSTOP ASSY, LH, SPLIT PLATFORM, S1132, 26"	1	V1-PF-122
3-1	ROLLSTOP ASSY, RH, SPLIT PLATFORM, 30"	1	V2-PF-123
3-2	ROLLSTOP ASSY, RH, SPLIT PLATFORM, S1132, 26"	1	V1-PF-123
4-1	KIT, REPLACEMENT, ROLLSTOP ACTUATOR, LH, W/HDWR	1	22903
4-2	ROLLSTOP ACTUATOR ASSY, LH, S1132	1	V1-PF-003
5-1	KIT, REPLACEMENT, ROLLSTOP ACTUATOR, RH, W/HDWR	1	22902
5-2	ROLLSTOP ACTUATOR ASSY, RH, S1132	1	V1-PF-002
6	SPACER, ROLLSTOP	2	UV-PF-839
7	BLOCK, PLATFORM LEVEL ADJUSTMENT	2	VT-AH-142
8	BUMPER, RUBBER (BAG OF 10)	2	20653
9	SCREW, HEX HEAD, 1/4-20 X 7/8" (BAG OF 10)	2	15920
10	WASHER, FLAT, .64OD X .28ID X.065 (BAG OF 10)	2	17504
11	NUT, HEX, 1/4-20, NYLON INSERT (BAG OF 10)	2	15919
12	"T" NUT, SST (BAG OF 10)	2	14485
13	BUSHING, BRONZE, .39 ID	2	V2-BU-195
14	BUMPER, UHMW PLASTIC, 75 D X .38 T	2	V2-AC-027
15	NUT, HEX, NYLON INSERT, 5/16-18 (BAG OF 10)	2	13349
16	SCREW, BUTTON HEAD, 5/16-18 X 1/2", SST (BAG OF 10)	7	17506
17	NUT, HEX, 5/16-18 (BAG OF 10)	7	19714
18	SCREW, TEK PAN HEAD, #8 X 3/4" (BAG OF 10)	2	15911
19	SCREW, HEX HEAD, 5/16-18x1, GR5 (BAG OF 10)	2	15953
20	SCREW, HEX HEAD, 1/4-20 x 1/2", GR5 (BAG OF 10)	2	34518
21	PIN, CLEVIS, 5/16 x 1-1/4, (BAG OF 10)	2	19513
22	ATTACHMENT, RODEND, GRAY	2	36279
23	WASHER, FLAT, .81OD X .41ID x .065 (BAG OF 10)	2	17510
24	SCREW, FLAT HEAD, 3/8-16 x 3/4" (BAG OF 10)	4	11792
25	SET SCREW, 1/2-20 X 1-1/4" (ADJUSTING SCREW), (BAG OF 10)	2	19704
26	SET SCREW, 1/4-20 x 1/4", CUP POINT (BAG OF 10)	2	13312
27	SAFETREAD, 2.75" X 14"	2	V2-AC-41
28	RING, RETAINING, .25"OD (BAG OF 10)	8	11793
29	WASHER, NYLON, .318 ID X .751 OD X .031 (BAG OF 10)	4	14467
30	SCREW, BUTTON HEAD, 1/4-20 X 3/8, SST (BAG OF 10)	2	13309
31	GUIDE, 1.00 OD X 1/4-20 ID X 0.33	2	UL-AC-034
32	SCREW, BUTTON HEAD, 5/16-18 X 1/2, SST (BAG OF 10)	2	17506
33-1	KIT, REPLACEMENT LATCH MECHANISM	1	01099
33-2	CATCH, BASE LATCH (44720 - present)	1	V2-AC-103
34	RETAINING RING, EXT, .75" (BAG OF 10)	2	11796
35	BUSHING, FLANGED, 1" ID X 1/2W" (BAG OF 10)	2	19579
36	SAFETREAD, 9.75 X 5.50, BLACK	2	25653
38-1	INNER ROLLSTOP, 30" ASSY	1	V2-PF-141
38-1	KIT, INNER ROLLSTOP RETROFIT W/HDWR	1	01029
38-2	INNER ROLLSTOP, 26" ASSY	1	V1-PF-212
39	ASSEMBLY, TIE ROD	2	VS-AH-08
40	BALL JOINT, RH THREAD	2	VS-AH-03
41	STUD, TIE ROD, LH THREAD TO RH THREAD	2	VS-AH-07
42	BALL JOINT, LH THREAD, SST	2	VS-AH-02
43	WASHER, SPLIT LOCK, 5/16" (BAG OF 10)	4	13384
44	NUT, HEX, 5/16-24 (BAG OF 10)	4	15988
45-1	SHAFT, MAIN, PLATFORM, 1" X 37.25	1	VT-PI-43
45-2	SHAFT, MAIN, PLATFORM, 1" X 33.25	1	VS-PI-14
46	SHIM, PVC	2	V2-BU-091
47	PLUG, SQUARE, 1 1/8, BLACK PLASTIC	2	10258
48	BUSHING, STEEL, .25ID X .32OD X .19L	2	V2-BU-003
49	COLLAR, .39ID	2	VS-BU-02
50	SET SCREW, 1/4-20 X 1/4, CONE POINT (BAG OF 10)	4	14492

51	SPRING, TORSION, RH	1	V3-SP-22
52	SPRING, TORSION, LH	1	V3-SP-21
53	PIN, HINGE, SPLIT PLATFORM DOOR (ONLY FOR 30 X 48 SPLIT PLATFORM)	4	VS-PI-01

* Fully assembled platform with all items shown in Figure 4-6, except items 45 and 46.

This page intentionally left blank.

S-SERIES TRAVELING FRAME
SERIAL NO's. 32000 - PRESENT

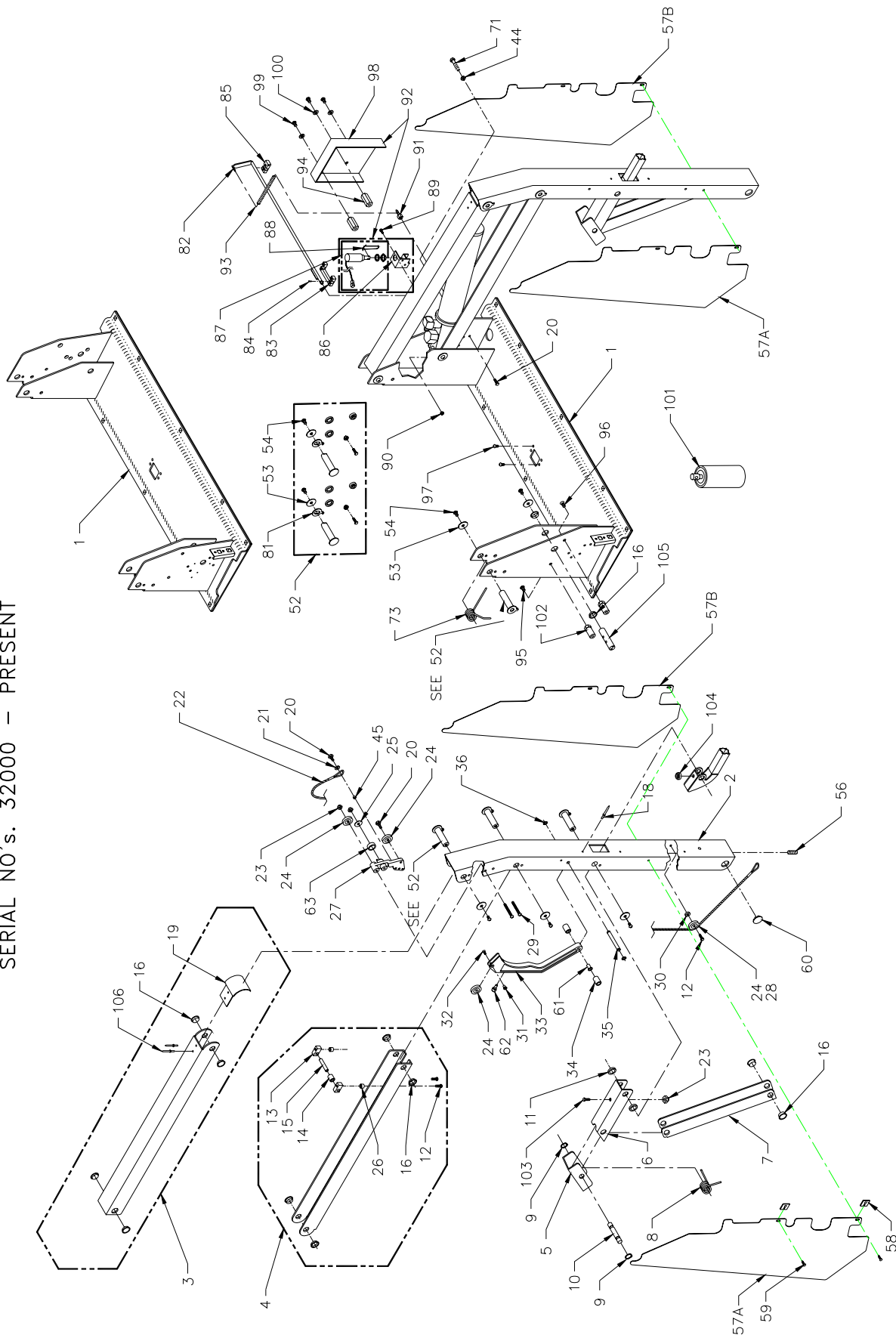

FIGURE 4-6: S-SERIES TRAVELING FRAME

**FIGURE 4-6: S-SERIES TRAVELING FRAME
(ALL MODELS) WHEELCHAIR LIFT SERIAL NO's. 32000 - PRESENT**

REF.	DESCRIPTION	QTY.	PART NO.
1-1	BASEPLATE ASSY, 26", w/INTERLOCK, S1100	1	14450
1-2	BASEPLATE ASSY, 30", w/o INTERLOCK	1	14452
	BASEPLATE ASSY, 30", w/INTERLOCK	1	14453
	BASEPLATE ASSY, 30", w/o INTERLOCK, RH	1	14452R
	BASEPLATE ASSY, 30", w/INTERLOCK, S1100	1	14451
1-3	BASEPLATE ASSY, 32", w/o INTERLOCK	1	14454
	BASEPLATE ASSY, 32" w/INTERLOCK	1	14455
	BASEPLATE ASSY, 32" ,w/o INTERLOCK, RH	1	14454R
2-1	VERTICAL ARM ASSY, RH, S1200	2	VS-AC-241
	VERTICAL ARM ASSY, LH, S1200	2	VS-AC-242
2-2	VERTICAL ARM ASSY, S2000	2	VT-AC-141
	VERTICAL ARM ASSY, S5000	2	V5-AC-141
2-3	VERTICAL ARM ASSY, RH, S1100, (S/N's 32000-62043)	2	V1-AC-241
	VERTICAL ARM ASSY, LH, S1100, (S/N's 62044 - present)	2	V1-AC-242
3-1	TOP ARM ASSY, S1200	2	VS-AC-250
3-2	TOP ARM ASSY, S2000	2	VT-AC-250
3-3	TOP ARM ASSY, S5000	2	V5-AC-250
4-1	BOTTOM ARM ASSY, S1200	2	VS-AC-252
4-2	BOTTOM ARM ASSY, S2000	2	VT-AC-252
4-3	BOTTOM ARM ASSY, S5000	2	V5-AC-252
5	SADDLE ASSEMBLY	2	VT-AC-046
6	LINK KNUCKLE LEVER ASSY	2	VT-AC-070
7-1	LINK, VERTICAL KNUCKLE ASSY, S1200, w/LOAD SENSOR	1	VS-AC-058
7-2	LINK, VERTICAL KNUCKLE ASSY, S2000, w/LOAD SENSOR	1	VT-AC-058
7-3	LINK, VERTICAL KNUCKLE ASSY, S5000, w/LOAD SENSOR	1	V5-AC-058
7-4	LINK, VERTICAL KNUCKLE ASSY, S1100, w/LOAD SENSOR, SOLID PLATFORM	1	V1-AC-058
7-5	LINK, VERTICAL KNUCKLE ASSY, S1100, w/LOAD SENSOR, SPLIT PLATFORM	1	V1-AC-158
7-6	LINK, VERTICAL KNUCKLE ASSY, S1200, w/o LOAD SENSOR	2**	VS-AC-069
7-7	LINK, VERTICAL KNUCKLE ASSY, S2000, w/o LOAD SENSOR	2**	VT-AC-069
7-8	LINK, VERTICAL KNUCKLE ASSY, S5000, w/o LOAD SENSOR	2**	V5-AC-069
7-9	LINK, VERTICAL KNUCKLE ASSY, S1100, w/o LOAD SENSOR, SOLID PLATFORM	2**	V1-AC-069
7-10	LINK, VERTICAL KNUCKLE ASSY, S1100, w/o LOAD SENSOR, SOLID PLATFORM	2**	V1-AC-071
8-1	SPRING, KNUCKLE ACTUATOR (S/N's 31999 AND BELOW)	2	VT-SP-45
8-2	SPRING, KUNCKLE ACTUATOR (S/N's 32000 - present)	2	VT-SP-42
9	RETAINING RING, .75" EXT (BAG OF 10)	1	11796
10	PIN, SNAP RING, 0.75 OD X 2.15L	2	VT-PI-41
11	SPACER, KNUCKLE LINK	4	VT-BU-42
12	SCREW, BUTTON HEAD, 1/4-20 X 1", SST (BAG OF 10)	1	19715
13	RETAINER, CAM ROLLER	4	V2-AC-025
14-1	ROLLER, BRIDGEPLATE CAM (S2000 & S5000)	2	V2-AC-124
14-2	ROLLER, BRIDGEPLATE CAM (S1000 & S1200)	2	V2-AC-024
15	PIN, CAM ROLLER	2	V2-PI-094
16	FLANGED BUSHING, .75ID (BAG OF 10)	3	19576
18	RIVET, BLIND, 3/16 X 1/2", ALUM (BAG OF 10)	1	15918
19	CAP, UPPER PARALLEL ARM	2	V2-AC-89
20-1	SCREW, HEX HEAD, 1/4-20 x 3/4, GR5 (BAG OF 10)	4	13308
20-2	SCREW, FLAT HEAD, 1/4-20 x 1/2 (BAG OF 10)	1	15928
21	WASHER, FLAT HEAD, .63OD x .28ID x .065 (BAG OF 10)	2	17504
22-1	CABLE ASSY, REPLACEMENT, BRIDGEPLATE, S1200, 49.50"	2	16093
22-2	CABLE ASSY, REPLACEMENT, BRIDGEPLATE, S2000, 52.50"	2	16094
22-3	CABLE ASSY, REPLACEMENT, BRIDGEPLATE, S5000, 55.50"	2	16095
22-4	CABLE ASSY, REPLACEMENT, BRIDGEPLATE, S1100, 45.00"	2	13661
23	NUT, HEX, 1/4-20, NYLON INSERT (BAG OF 10)	2	15919
24	BEARING, GROOVED	8	VS-AH-06
25	WASHER, FENDER, 1.00OD x .28ID x .065 (BAG OF 10)	2	25623
26	STAND OFF, .38 LG, 1/4" ID X 1/2" OD	4	V2-AC-011
27	BLOCK, PULLEY MOUNT, IRS	2	V2-AC-112
28	BEARING, GROOVED, 1" OD, .25 ID, S1100 only, (S/N's 62044 - present)	2	25374

* Item 7 is used on serial no.'s 103,999 and below.

REF.	DESCRIPTION	QTY.	PART NO.
29	SCREW, BUTTON HEAD, 1/4-20 x 2 1/4, SST, BLK OXIDE (BAG OF 10)	1	19720
30	BUSHING, 5/8 OD X 3/16L	2	VS-AH-13
31	T-NUT, FLAT HEAD, 10-24 X .25 OD X .44L	2	V2-AC-015
32	SCREW, FLAT HEAD, 10-24 x 1/2 (BAG OF 10)	1	13303
33	CAM, ASSY, BRIDGEPLATE ACTUATOR	2	V2-AC-190
34	KIT, SPACER, RUBBER, BRIDGEPLATE CAM	4	01224
35	PIN, SNAP RING, .38OD X 3.09 L	2	VS-PI-09
36	RETAINING RING, .38ID (BAG OF 10)	1	11795
45	BUSHING, STEEL, 251D X 320D X .19L	2	V2-BU-003
51	PIN, LINK ARM	6	16679
52	KIT, RETROFIT, PIN, LINK, ARM ASSY	3	16679
53	WASHER, FENDER, 5/16, SST (BAG OF 10)	1	15921
54	SCREW, BUTTON HEAD, 5/16-18 X 1/2 SST (BAG OF 10)	1	14494
56	SETSCREW, 3/8-16 x 3/8, CUP PT (BAG OF 10)	1	11797
57A	KIT, PINCH POINT SHIELD W/HDWR, S2030, S2034 & S2035	2	29162
57A	KIT, PINCH POINT SHIELD W/HDWR, S5030	2	29163
57B	KIT, PINCH POINT SHIELD W/HDWR, S2030, S2034, S2035	2	29178
57B	KIT, PINCH POINT SHIELD W/HDWR, S5030	2	29179
58	SPRING NUT, 10-24, U-TYPE (BAG OF 10)	1	11799
59	SCREW, PAN HEAD, 10-24 x 1/2 (BAG OF 10)	1	13304
60	PLUG, 1" LOW PROFILE, BLK NYLON (S/N's 52246 - present)	2	25563
61	BEARING, NYLINER, 3/8 ID 11/16 LONG (S/N's 56000 - present)	2	25562
62	BUMPER, BUTTON, BRIDGEPLATE CAM, (BAG OF 10)	1	19783
63	BUMPER, BRIDGEPLATE CAM, ANTI-RATTLE (S/N's 56000 - present)	2	V2-BU-090
71	SCREW, HEX HEAD, 1/4-20 X 1-3/4, GR5 (BAG OF 10)	1	25696
73	SPRING, UPPER PARALLEL ARM	2	V2-SP-97
80	SETSCREW, 5/16-18 x 1, CUP PT (BAG OF 10)	1	15830
81	WASHER, KEYED, PAINTED	2	20258
82-1	KIT, LATCH RELEASE, 30", w/BLOCKS & HDWR	1	28768
82-2	KIT, LATCH RELEASE, 26", w/BLOCKS & HDWR	1	28767
83-1	BLOCK, MOUNTING, BASE LATCH, (S/N's 32000 - 44719)	2	V2-AC-001
83-2	BLOCK, CENTER MOUNTING, BASE LATCH (S/N's 44720 - present)	1	V2-AC-102
84	DOWEL PIN, .094 DIA X .38 L (BAG OF 10)	1	25615
85	BLOCK, MOUNTING, BASE LATCH	1	V2-AC-001
86	BRACKET, STOW LOCK SOLENOID (S/N's 50517 - present)	1	V2-AC-108
87-1	SOLENOID ASSY, 12V (S/N's 50517 - present)	1	V2-ES-127
87-2	SOLENOID ASSY, 24V (S/N's 50517 - present)	1	V2-ES-128
88	CLIP, SPRING, BASE LATCH	1	V2-AC-009
89-1	SCREW, PAN HEAD, 10-24 x 1/2 (BAG OF 10)	1	13304
89-2	SCREW, FLAT HEAD, 10-24 x 1/2, SST (BAG OF 10)	1	14426
90	NUT, HEX, NYLON INSERT, 10-24 (BAG OF 10)	1	13382
91	PIN, SPRING MOUNTING	1	V2-P1-095
92-1	KIT, REPLACEMENT SOLENOID, 12V (S/N's 32000-50516)	1	01238
92-2	KIT, REPLACEMENT SOLENOID, 24V (S/N's 32000-50516)	1	01239
93	SPRING, DOOR HELPER, .38OD X 3.5"	1	V2-SP-093
94	BUSHING, LATCH COVER	2	V2-BU-080
95	SCREW, HEX HEAD, 5/16-18 X 3/4" (BAG OF 10)	1	15901
96	SCREW, FLAT HEAD, 5/16-18 X 3/4 (BAG OF 10)	1	14499
97	SCREW, BUTTON HEAD, 1/4-20 X 1/2", SST (BAG OF 10)	1	15902
98	COVER, BASE LATCH (S/N's 50517 - present)	1	V2-CV-123
99	SCREW, HEX HEAD, 5/16-18 X .625 (BAG OF 10)	1	14495
100	WASHER, FLAT, .69OD x .34ID x .065 (BAG OF 10)	1	13350
101	TOUCH-UP SPRAY PAINT, CHARCOAL	1	25340
102	BUSHING, E-COVER MOUNT	2	V2-BU-081
103	SCREW, HEX HEAD, 1/4-20 X 1, GR5 (BAG OF 10)	1	14493
104	GROMMET, .30ID x .88OD x .44 (BAG OF 10)	1	23391
105-1	PIN, CONTROL CAM, (S/N's 62560 - present)	1	V2-PI-091
105-2	KIT, CONTROL CAM, RETROFIT	1	01287
106	RIVET, BLIND, STEEL 3/16 X 5/8 (BAG OF 10)	4	34519

** Item quantity is one each for s/n's 103,999 and below and quantity is two each for s/n's 104,000 and above.

This page intentionally left blank.

S-SERIES STANDEE HANDRAIL (EXPORT)
SERIAL NO's. 32000 - present

EXPORT
06/01/04

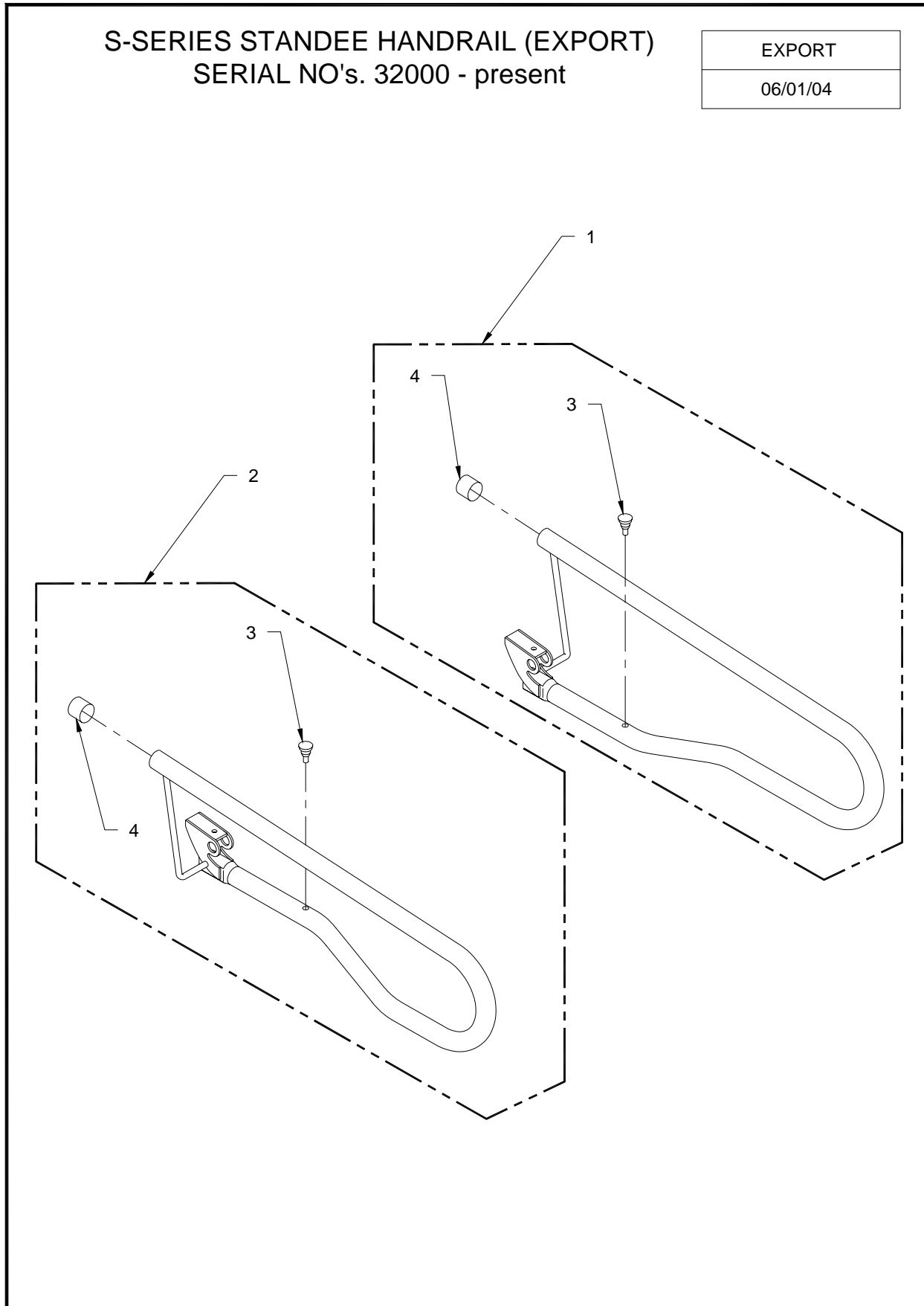

FIGURE 4-7: STANDEE HANDRAIL (EXPORT)

FIGURE 4-7: STANDEE HANDRAIL (EXPORT)
SERIAL NO's. 32000 - PRESENT

REF.	DESCRIPTION	QTY.	PART NO.
1	KIT, HANDRAIL ASSY, OFFSET, RH	1	VT-AC-364
2	KIT, HANDRAIL ASSY, OFFSET, LH	1	VT-AC-363
3	BUMPER, RUBBER (BAG OF 10)	2	20653
4	CAP, ROUND, BLACK	2	25550

This page intentionally left blank.

**APPENDIX 1
LIFT SPECIFICATIONS**

S-SERIES EXPORT USE WHEELCHAIR LIFT								
Power electro-hydraulic motor				Rated load capacity 800 lbs (364 kg)				
Pump rating @ 12 volts DC 65 amp avg/cycle, 1250 psi				Manual backup (up) manual hand pump				
Pump rating @ 24 volts DC 32.5 amp avg/cycle, 1250 psi				Manual backup (down) manual pressure release valve				
Hydraulic cylinders 2ea, 1.5", power-up/grav				Lift Weight S-2030: 350 lbs (159 kg)				
				S-5030: 375 lbs (170 kg)				
DIMENSIONS, inches (mm)								
	A	B	C	D	E	F	G	H
MODEL	Stationary frame width	Height (folded)	Installation depth (folded)	Usable platform width	Usable platform length	Floor-to-ground travel	Traveling frame width	Clear entry width
S-2030	45 (1143)	55 (1397)	21.5 (546)	30 (762)	48 (1219)	42 (1067)	37.5 (953)	31 (787)
S-2034	45 (1143)	70 (1778)	21.5 (546)	30 (762)	63 (1600)	42 (1067)	37.5 (953)	31 (787)
S-2035	45 (1143)	55 (1397)	14 (356)	30 (762)	48 (1219)	42 (1067)	37.5 (953)	31 (787)
S-5030	45 (1143)	57.75 (1467)	21.5 (546)	30 (762)	48 (1219)	48 (1219)	37.5 (953)	31 (787)

NOTES: