

### IV. SPARE PARTS

This chapter contains parts diagrams and parts list for the Ricon K-series (KlearVue) Wheelchair Lift. The exploded views of major lift assemblies show individual, or kit components, referenced by numbers. On the associated lists are the reference numbers, part descriptions, quantities used, and Ricon part numbers. For part numbers of lift decals, refer to the "Decal Locations and Part Numbers" figure at the end of Chapter II of this manual.

**NOTE:** To order a part: locate the part or assembly on an exploded view, note its reference number, find this number on the associated parts list (following page), and order the part number in the far right column. Most kits contain a single part (plus hardware). Therefore, you may need to order more than one kit if the part is used more than once on a major assembly.

**NOTE:** Some major lift components that are typically painted gray may also be produced in other colors, such as red, yellow, blue, black, and white. These components include the platform assembly, handrails, vertical arms, top and bottom arms, and baseplate assembly. These colored components are available from Ricon as spare parts.

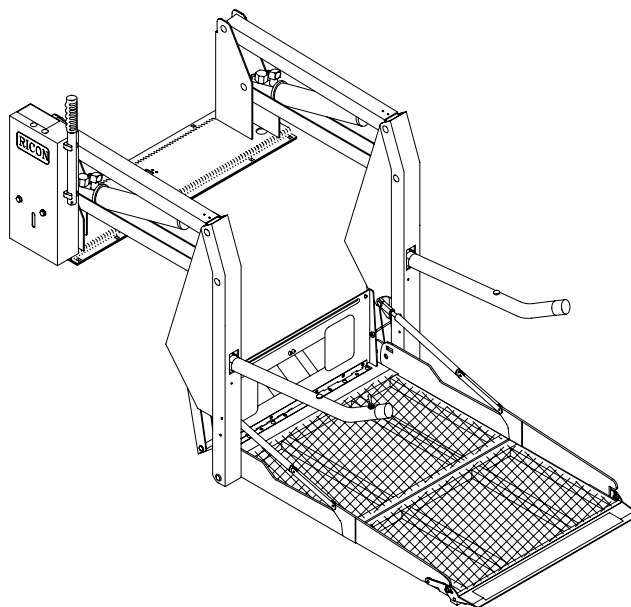

<b>DIAGRAM</b>	<b>PAGE</b>
FIGURE 4-1 HYDRAULIC POWER UNIT .....	4-2
FIGURE 4-2 HYDRAULIC SYSTEM .....	4-6
FIGURE 4-3 ELECTRICAL SYSTEM .....	4-8
FIGURE 4-4 PENDANT .....	4-10
FIGURE 4-5 FOLDING PLATFORM ASSEMBLY, K1132 .....	4-12
FIGURE 4-6 FOLDING PLATFORM ASSEMBLY, K1200 .....	4-14
FIGURE 4-7 FOLDING PLATFORM ASSEMBLY, K1203 .....	4-16
FIGURE 4-8 FOLDING PLATFORM ASSEMBLY, K1205 .....	4-18
FIGURE 4-9 FOLDING PLATFORM ASSEMBLY, K2003 .....	4-20
FIGURE 4-10 FOLDING PLATFORM ASSEMBLY, K2005 .....	4-22
FIGURE 4-11 FOLDING PLATFORM ASSEMBLY, K5005 .....	4-24
FIGURE 4-12 TRAVELLING FRAME .....	4-26
FIGURE 4-13 PINCH POINT SHIELDS .....	4-30
FIGURE 4-14 HANDRAIL ASSEMBLIES .....	4-32
FIGURE 4-15 ADA HANDRAIL ASSEMBLIES .....	4-34
APPENDIX 1 K-SERIES LIFT SPECIFICATIONS .....	4-36

DATE: 05/05/04
DWG. SSX00001
REV K

MONARCH HYDRAULIC POWER UNIT #1  
SERIAL NO's. 31000-31999  
SERIAL NO's. 35000 - PRESENT

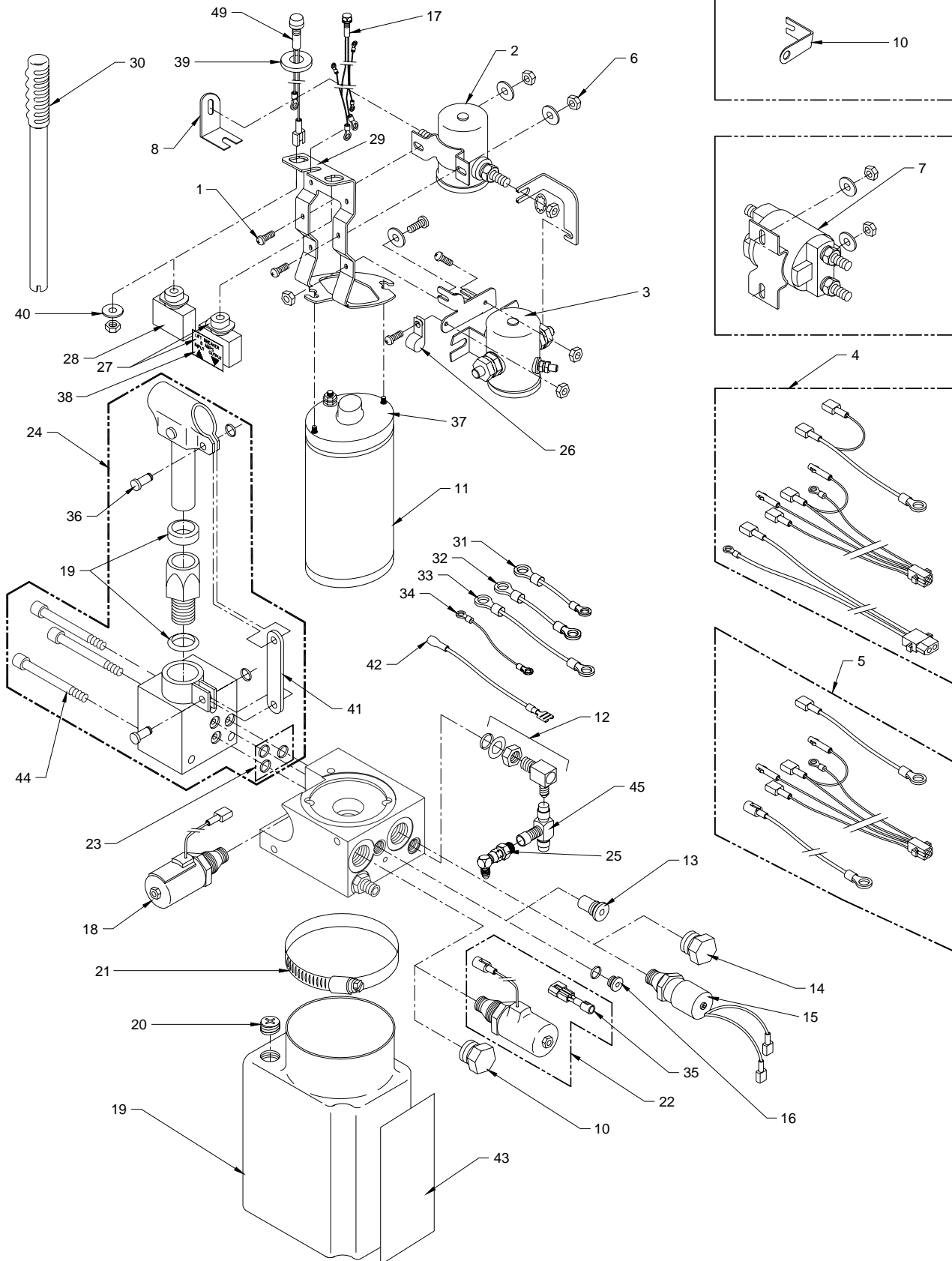

FIGURE 4-1: MONARCH HYDRAULIC POWER UNIT #1

FIGURE 4-1: MONARCH HYDRAULIC POWER UNIT

REF.	DESCRIPTION	QTY.	PART NO.
1	SCREW, PAN HEAD, 10-24 X ½, SELF THREAD	3	28111T
2	KIT, SOLENOID, 12V, DPST, CONT DUTY	1	20668
3	SOLENOID, SPST, 24V	1	26449
4	HARNESS, PUMP, w-DOOR INTERLOCK, (S/N's 32000-95999)	1	V2-ES-100
	HARNESS, PUMP, w-DOOR INTERLOCK, (SN's 96000 - present)	1	10069
5	HARNESS, PUMP, w/o DOOR INTERLOCK, (S/N's 32000-95999)	1	V2-ES-150
	HARNESS, PUMP, w/o DOOR INTERLOCK, (SN's 96000 - present)	1	10335
6	NUT, NYLON INSERT, 10-24, (BAG OF 10)	3	13382
7	KIT, SOLENOID, 12V, DBL POLE, w/HDWR	1	20670
	KIT, SOLENOID, 24V, DBL POLE, w/HDWR	1	20669
8	BUS BAR, MOTOR, SP SOLENOID, (S/N's 52456-95999) (DISCONTINUED)	1	V2-ES-034
	BUS BAR (SN 96000 - present)	1	10807
9	BUS BAR, MOTOR, DP SOLENOID, (S/N's 32000-95999) (DISCONTINUED)	1	UV-ES-040
10	BUS BAR (S/Ns' 96000 - present)	1	13087
11-1	MOTOR ASSY, 12V, 3", MONARCH PUMP (P/N V2-SH-115 DISCONTINUED)	1	14345
11-2	MOTOR ASSY, 24V, 3", MONARCH PUMP (P/N V2-SH-116 DISCONTINUED)	1	14346
11-3	MOTOR ASSY, 12V ISKRA (SN's 96000 - present) (DISCONTINUED)	1	14332
	MOTOR ASSY, w-BRACKET, 12V ISKRA	1	14345
11-4	MOTOR ASSY, 24V ISKRA (SN's 96000 - present) (DISCONTINUED)	1	14333
	MOTOR ASSY, w-BRACKET, 24V ISKRA	1	14346
12	FITTING ASSY, ELBOW, #4 STD THD X #4 JIC, w-HDWR	1	18235
13	DECELERATION VALVE ASSY	1	V2-SH-279
14	PLUG, 3/4-16 CAVITY, w-O-RING (DISCONTINUED)	2	V2-SH-001
15	KIT, PRESSURE SWITCH, W/INSTRUCTIONS (P/N 16640 SUPERSEDED)	1	42050
16	PLUG w/O-RING	1	V2-SH-182
17	LIGHT ASSY, INDICATOR, 12V (P/N 15207 DISCONTINUED)	1	35739
18-1	VALVE ASSY, POPPET, DELTROL, 12V	1	V2-SH-105
18-2	VALVE ASSY, POPPET, DELTROL, 24V (DISCONTINUED)	1	V2-SH-136
19	RESERVOIR, PUMP, PLASTIC w/DECAL & PLUG	1	30938
20	PLUG, BREATHER, RESERVOIR,	1	V2-SH-106
21	HOSE CLAMP	1	V2-SH-109
22-1	SPOOL VALVE ASSY, 12V, ADA APPLICATIONS	1	01176
22-2	SPOOL VALVE ASSY, 24V, ADA APPLICATIONS	1	01177
23	SEAL KIT, MANUAL BACK-UP PUMP	1	V2-SH-220
24	BACK-UP PUMP, MANUAL	1	V2-SH-210
25	FITTING ASSY, SNL, 1/4J X 1/4J, STEEL	1	VS-SH-06
26-1	CABLE CLAMP, 3/8", NYLON, (BAG OF 10)	1	18660
26-2	CABLE CLAMP, 3/16", NYLON, (BAG OF 10)	1	19798
26-3	CABLE CLAMP, 5/16", NYLON, (BAG OF 10)	1	19772
26-4	CABLE CLAMP, ½", NYLON, (BAG OF 10)	1	19774
27	CIRCUIT BREAKER, 8 AMP, w/HDWR & DECAL	1	V2-SH-005
28	CIRCUIT BREAKER, 30 AMP, w/HDWR	1	26510
29-1	BRACKET, SOLENOID MOUNTING (S/N's 32000-95999)	1	V2-SH-127
29-2	BRACKET, SOLENOID ISKRA (S/N's 96000 - present)	1	10507
30	HANDLE, MANUAL BACK-UP PUMP	1	V2-SH-111

REF.	DESCRIPTION	QTY.	PART NO.
31	JUMPER, DPDT SOLENOID, BLK, 10GA, 5.0"	1	ELJ00121
32	JUMPER, DPDT SOLENOID, w/ISOLATED GROUND, BLK, 10GA, 5.5"	1	ELJ00122
33	JUMPER, DPDT SOLENOID, RED, 10GA, 5.5"	1	ELJ02055
34	JUMPER, DPDT SOLENOID, ORG, 18GA, 5.0"	1	ELJ03061
35	DIODE BLOCK ASSEMBLY	1	08232
36	PIN & RETAINING RING	2	V2-SH-017
37-1	KIT, PUMP MOTOR BRUSH SET (S/N's 32000-95999) (DISCONTINUED)	1	V2-SH-115B
37-2	KIT, PUMP MOTOR BRUSH SET (S/N's 96000 - present)	1	14334
38	DECAL, 8 AMP CIRCUIT BREAKER (DISCONTINUED)	1	26290
39	ADAPTER, .625 D-HOLE TO .484 ROUND	1	V2-ES-059
40	WASHER, FLAT, 7/16 (S/N's 61878 - present) (BAG OF 10)	1	19716
41	BRACKET, TENSION LINK, MONARCH PUMP	1	V2-SH-149
42-1	JUMPER, SWITCH, PRESSURE, RH PUMP	1	15860
42-2	JUMPER, SWITCH, PRESSURE, LH PUMP	1	15861
43	DECAL, OIL LEVEL WARNING	1	32-10-154
44	SCREW, HEX RECESS HEAD, 1/4-20X2	3	28490
45	FITTING, SRT, 1/4J, STEEL	1	V2-SH-012
46**	KIT, RETROFIT, 2nd SOLENOID, 12V	1	19068
47**	KIT, RETROFIT, 2nd SOLENOID, 24V	1	19843
48**	HARNESS, EXT, RH PUMP	1	V2-ES-155
49-1	LIGHT, LIFT ARMED INDICATOR, 12V (S/N's 61878 - present)	1	UL-ES-034
49-2	LIGHT, LIFT ARMED INDICATOR, 24V (S/N's 61878 - present)	1	V2-ES-016

\*\* Item not shown

This page intentionally left blank.

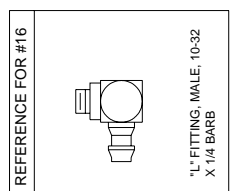
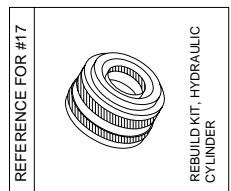
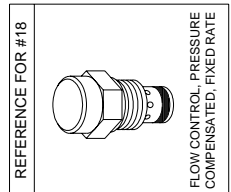
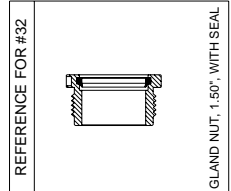
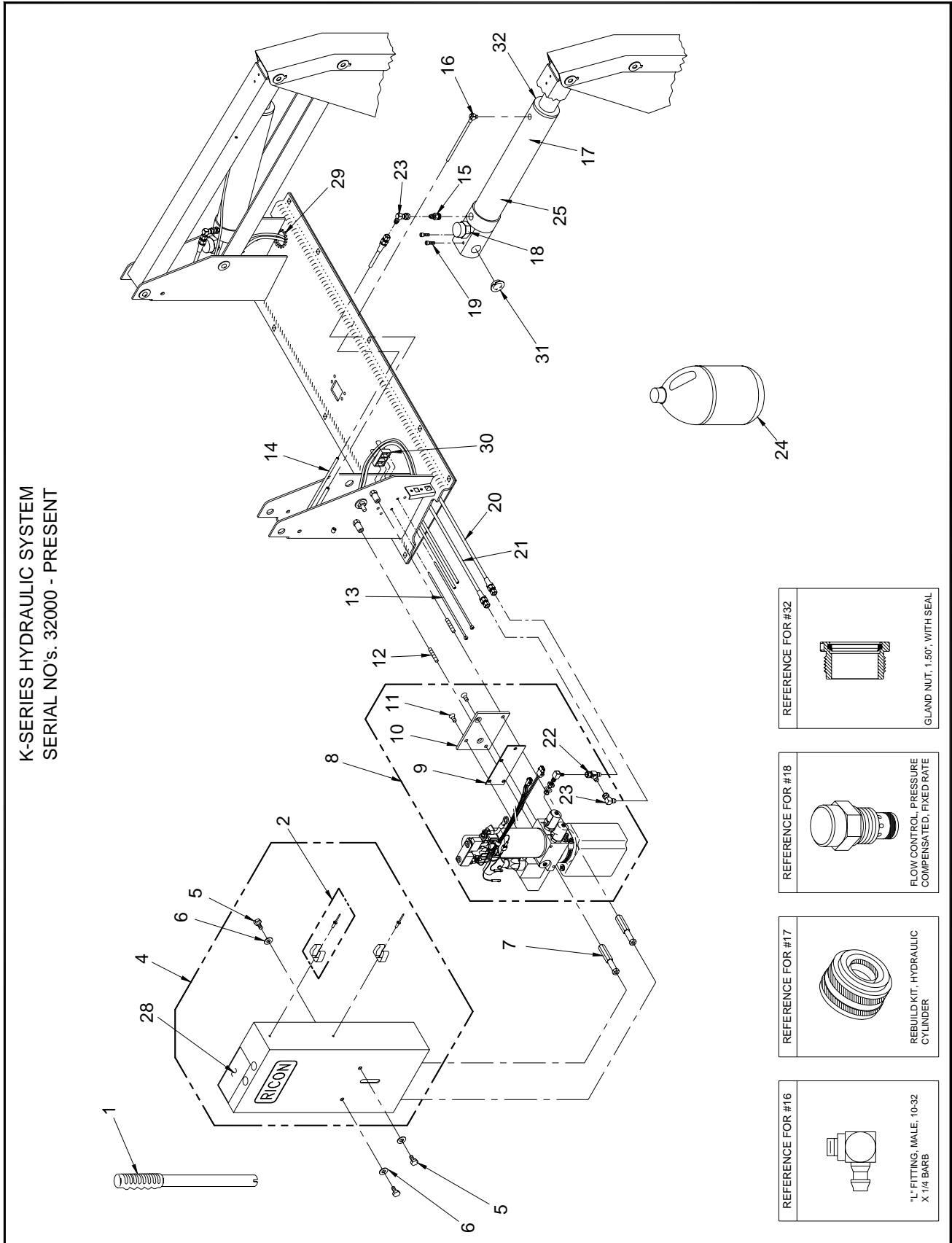

FIGURE 4-2: HYDRAULIC SYSTEM

FIGURE 4-2: HYDRAULIC SYSTEM

REF	DESCRIPTION	QTY	PART NO.
1	HANDLE, MANUAL BACKUP PUMP	1	V2-SH-111
2	KIT, TOOL CLIP, W/HDWR	2	19557
4-1	COVER, PUMP, RH	1	V2-CV-121
4-2	COVER, PUMP, LH (S/N's 31000-31999 & 35000-present )	1	V2-CV-220
5	SCREW, HEX HEAD, 5/16-18 X .625 (BAG OF 10)	3	14495
6	WASHER, FLAT, 5/16", SAE (BAG OF 10)	1	13350
7	HEX ROD, PUMP STANDOFF	2	V2-CV-015
8-1	HYDRAULIC PUMP, 12V, NOTOP, UV RES, 2KPSI	1	PM212002007
8-2	HYDRAULIC PUMP, 12V, W/INTLK & ANTIDRIFT (DISCONTINUED)	1	PM212090110
8-3	HYDRAULIC PUMP, 12V, COMMON BRKT (S/N's 31000 - 31999 & 35000 - present)	1	PM212090100
8-4	HYDRAULIC PUMP, 24V, COMMON BRKT (S/N's 31000 - 31999 & 35000 - present)	1	PM224110100
8-5	HYDRAULIC PUMP, 12V, COMMON BRKT (S/N's 32000 - 34999)	1	PM212090100
8-6	HYDRAULIC PUMP, 24V, COMMON BRKT (S/N's 32000 - 34999)	1	PM224110100
8-7	HYDRAULIC PUMP, 12V, COM BRKT, w/o INTLK, RH, DCL	1	PM212090308
8-8	HYDRAULIC PUMP, 24V, COM BRKT, w/o INTLK, RH, DCL	1	PM224100108
9	PLATE, PUMP COVER MOUNT	1	V2-AC-71
10	PLATE, PUMP MOUNTING	1	V2-AC-70
11	SCREW, FLAT HEAD, 5/16-18 X 3/4" (BAG OF 10)	2	14499
12	STUD, THREADED, 5/16-18 X 1.75" (BAG OF 10)	2	14500
13	CABLE TIE, 5.5", BLACK (BAG OF 10)	2	25697
14	TUBE, POLYURETHANE, 6MM x 4MM, BLACK	9'	22-02-230
15-1	ADAPTOR, STRAIGHT, 1/4 NPT MALE (S/N's 32000-63999)	2	V2-SH-84
15-2	ADAPTOR, # 6 SAE MALE X # 4 JIC MALE (S/N's 64000 - present)	2	26591
16	FITTING, "L", MALE 10-32 X 1/4 BARB	2	V2-SH-16
17	KIT, CYLINDER REPAIR, W-PISTON ASSY, GLAND NUT, AND SEAL	2	21829
18	KIT, FLOW CNTRL VALVE, PRESSURE COMPENSATED, FIXED RATE (2/KIT)	1	30968
19	SCREW, HEX RECESS HEAD, 1/4-20 X 1 (BAG OF 10)	4	14491
20	HOSE ASSY, 61" X 1/4 JIC X 1/4 JIC	1	V2-SH-009
21	HOSE ASSY, 26" X 1/4 JIC X 1/4 JIC	1	V2-SH-008
22	FITTING, RUN TEE, 1/4 JIC M-M-F	1	V2-SH-012
23	FITTING, "L", 1/4 JIC M-F SWIVEL	3	VS-SH-06
24	OIL, HYDRAULIC, TEXACO #15, MEETS MIL-H-5606G	1 GAL	20-16-051
25-1	CYLINDER ASSY, K-1100/1200	2	VS-SH-105
25-2	CYLINDER ASSY, K-2000	2	VT-SH-105
25-3	CYLINDER ASSY, K-5000	2	V5-SH-105
25-4	CYLINDER ASSY, K-55XX	2	30836
28	DECAL, MANUAL OPERATION (TOP, w/CB)	1	26214
29	GROMMET, CATERPILLAR, 3/16"	8.5"	26647
30	SPACER, CABLE, AND HOSE	2	25557
31	BUSHING, 3/4"ID X 3/8W	4	25381
32	GLAND NUT AND SEAL	2	13009

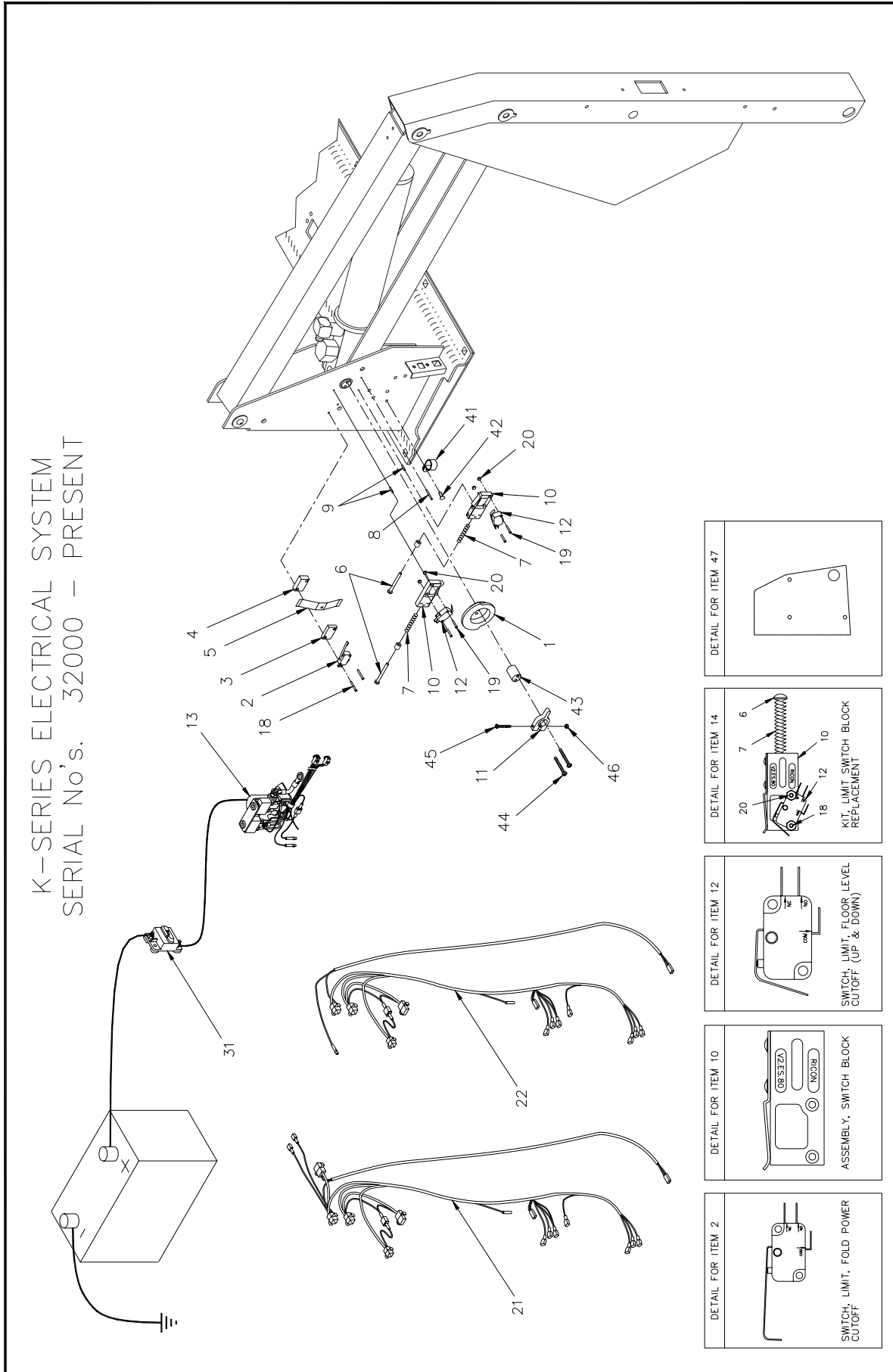

FIGURE 4-3: ELECTRICAL SYSTEM



FIGURE 4-3: ELECTRICAL SYSTEM

REF	DESCRIPTION	QTY	PART NO.
1-1	CAM, LIFT CONTROL w/SET SCREW (S/N's 32000-62559)	1	V2-ES-99
1-2	CAM, LIFT CONTROL (S/N's 62560 - present)	1	V2-AC-107
2	SWITCH, LIMIT, FOLD POWER CUTOFF	1	V2-ES-111
3	BLOCK, FOLD CUTOFF SWITCH OFFSET, 1/4" THICK	1	V2-ES-78
4	BLOCK, FOLD CUTOFF SWITCH OFFSET, 3/8" THICK	1	V2-ES-79
5	SPRING, RETAINING, UPPER AND LOWER SWITCH BLOCKS	1	V2-ES-95
6	SCREW, ROUND HEAD, 10-24 X 2" (ADJUSTING) (BAG OF 10)	2	14497
7	SPRING, COMPRESSION, .30 OD X 2.06L	2	V2-ES-93
8	ROLL PIN, .94 X 1.0 (TIMING PIN) (BAG OF 10)	1	14498
9	ROLL PIN, .94 X .50 (SWITCH BLOCK MOUNT) (BAG OF 10)	2	14496
10	SWITCH BLOCK ASSY, (UPPER & LOWER)	2	V2-ES-82
11-1	<b>KIT, RETRO, CAM (V2-BU-89 SUPERSEDED)</b>	1	<b>01287</b>
11-2	ACTUATOR, FOLD CUTOFF ( S/N's 62560 - present)	1	V2-AC-089
12	SWITCH, LIMIT, FLOOR LEVEL POWER CUTOFF (UP & DOWN)	2	V2-ES-110
13	SOLENOID BRACKET COMPONENTS (for replacement parts, refer to hydraulic power unit parts list drawing)	—	—
<b>13-1</b>	<b>CIRCUIT BREAKER, 8 AMP, BR8 (1908)</b>	<b>2</b>	<b>26401</b>
14	KIT, LIMIT SWITCH BLOCK REPLACEMENT	2	V2-ES-61
18	SCREW, PAN HEAD, 4-40 X 1.25 (BAG OF 10)	2	15908
19	SCREW, PAN HEAD, 4-40 X .75 (BAG OF 10)	4	15909
20	NUT, HEX, 4-40, (BAG OF 10)	4	15903
21	ELECTRICAL HARNESS, MAIN, w/DOOR OPERATOR INTERCONNECT	1	V2-ES-051
22	ELECTRICAL HARNESS, MAIN, w/o DOOR OPERATOR INTERCONNECT	1	V2-ES-050
31	KIT, CIRCUIT BREAKER, MAIN (90a)	1	01010K
41	CLAMP, CABLE, 11/16" (S/N's 53168 - present)	1	255161
42	MS, 10-24 X 1/2 PHIL PAN, (BAG OF 10)	1	13304
43	PIN, EXTENSION FOLD CUTOFF (S/N's 62560 - present) (BAG OF 10)	1	15914
44	MS 10-24 X 1 3/4 PHIL PAN (S/N's 62560 - present) (BAG OF 10)	2	15915
45	MS 8-32 X 1 1/4 PHIL PAN (S/N's 62560 - present) (BAG OF 10)	1	15906
46	NUT-HEX 8-32 NYLON INSERT (S/N's 62560 - present) (BAG OF 10)	1	15907
47	COVER, ELEC SYSTEM	1	V2-CV-110

PENDANT

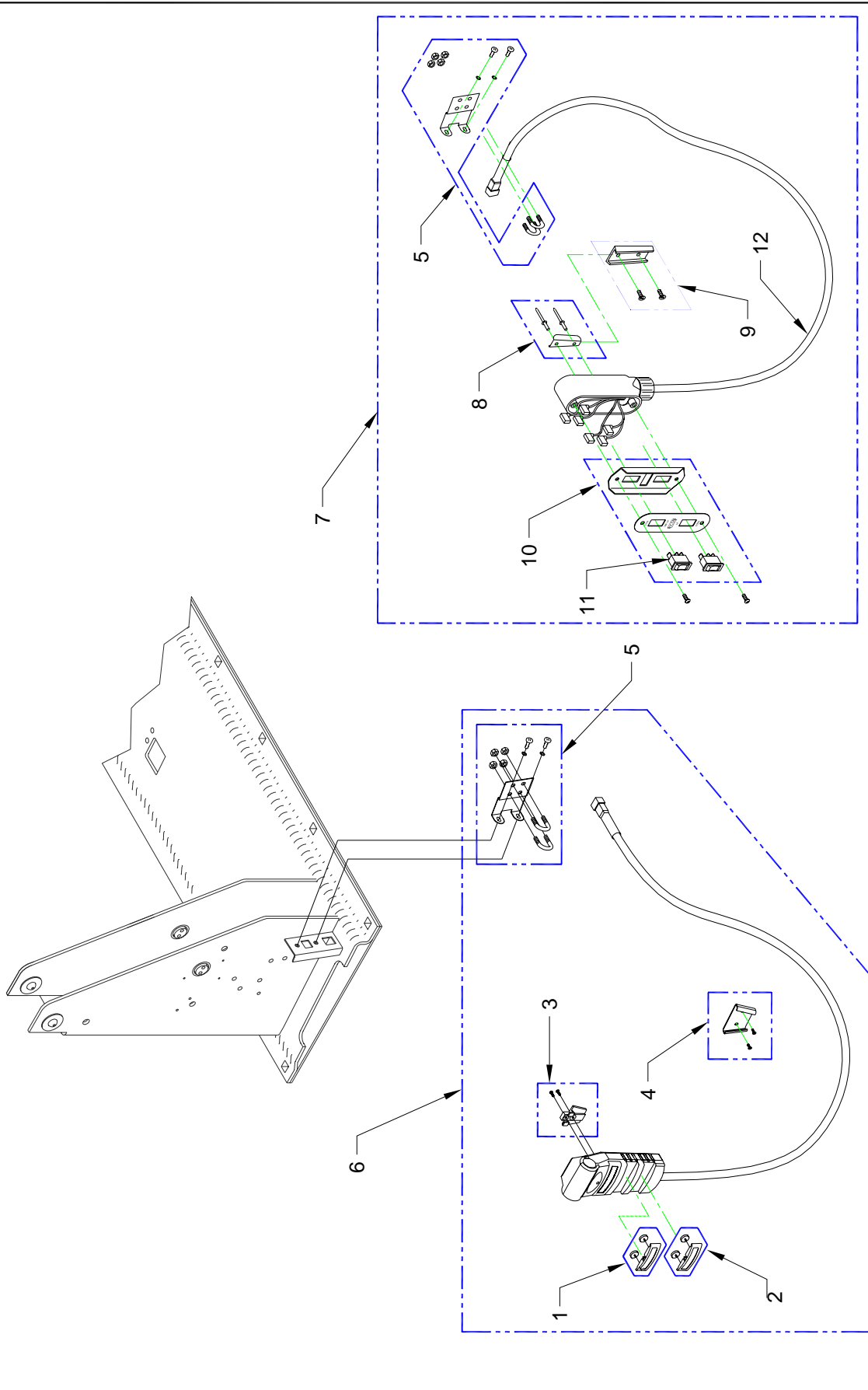

FIGURE 4-4: PENDANT

FIGURE 4-4: PENDANT

REF	DESCRIPTION	QTY	PART NO.
1	SPARE PARTS, STOW/DEPLOY BUTTON, K-SERIES	1	14731
2	SPARE PARTS, UP/DOWN BUTTON, K-SERIES	1	14732
3	SPARE PARTS, V-BRACKET, PLASTIC	1	14733
4	KIT, WALL MOUNT BRACKET, UNIVERSAL PENDANT	1	14709
5	KIT, CONTROL HARNESS STRAIN RELIEF, K-SERIES	1	01007
6-1	KIT, PENDANT, S-SERIES, 7 FT	1	14727
6-2	KIT, PENDANT, S-SERIES, COILED CORD	1	14728
6-3	KIT, PENDANT, S-SERIES, 10 FT	1	14729
6-4	KIT, PENDANT, S-SERIES, STEEL JACKETED CORD	1	14730
6-5	KIT, PENDANT, COIL CORD, FMVSS (33436 SUPERSEDED)	1	42968
7	KIT, PENDANT, OLD-STYLE (W/ROCKER SWITCH)	1	01008
8	KIT, CLIP, PENDANT, MALE W/RIVETS	1	28781
9	KIT, INSTL, PENDANT MTG CLIP	1	01118
10	FACEPLATE ASSY, PENDANT, SWITCH GD	1	V2-ES-035
11	SWITCH, SP ROCKER, ON-OFF-ON BLK	2	26455
12	HARNESS REPLACEMENT, 7FT CORD (for 01008 old style pendant, only)	1	V2-ES-024

K-LIFT FOLDING PLATFORM, K1132

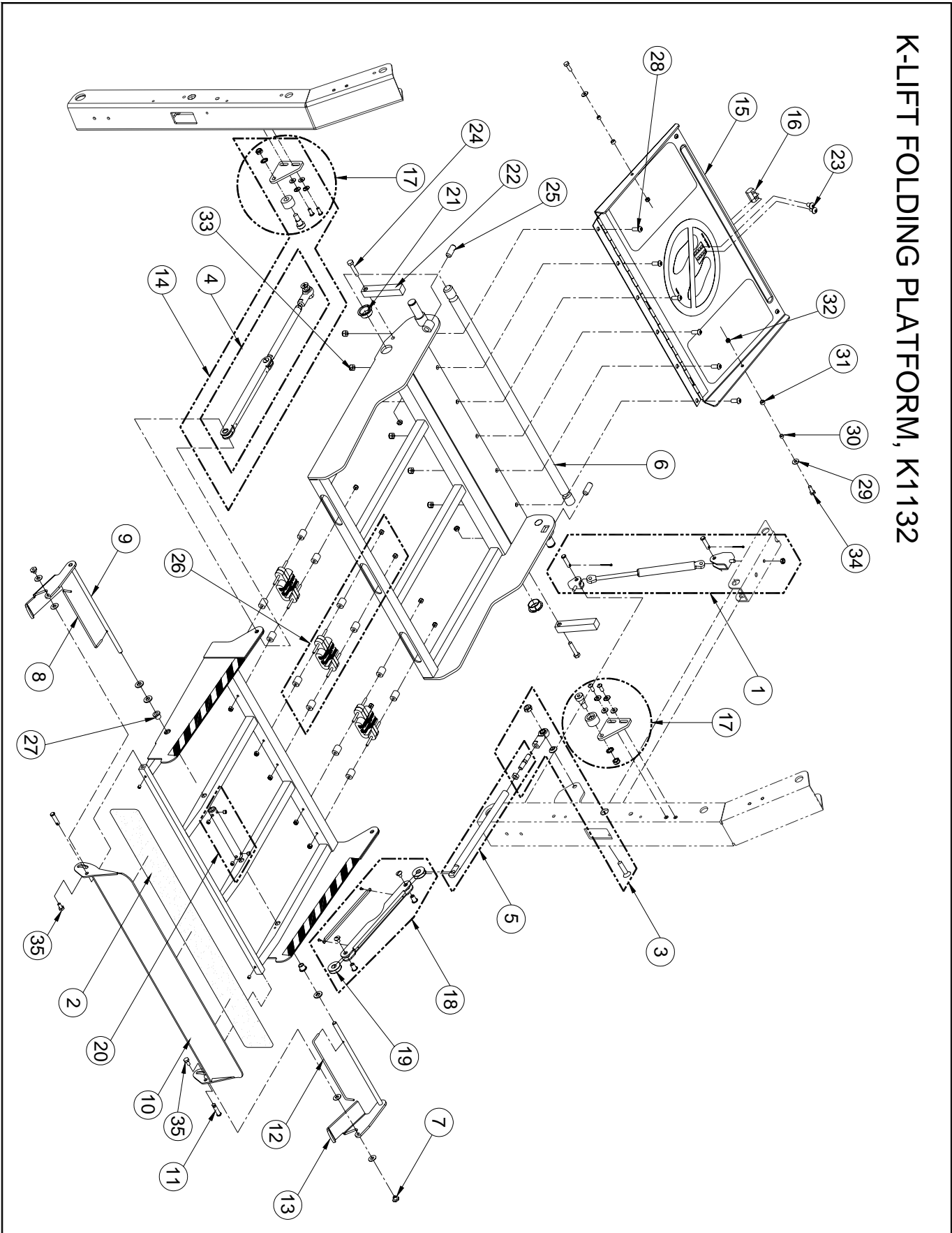

FIGURE 4-5: FOLDING PLATFORM ASSEMBLY, K1132

FIGURE 4-5: FOLDING PLATFORM ASSEMBLY, K1132

REF NO.	DESCRIPTION	QTY	PART
1	KIT, PNEUMATIC SPRING W-BRACKETS & HDWR	2	21647
2	SAFETREAD, 25.5" X 2/75", BLK	1	23047
3	ROD END ASSY, W/HDWR	1	29224
4	LINK ASSY	2	21645
5	KIT, LINK, REAR, 6.75", W/HDWR (left & right included in kit)	1	29244
6	SHAFT, MAIN, 1" X 32.50	1	VS-PI-14
7	T-NUT, ¼-20X1/4, SST (BAG OF 10)	2	14485
8	TORSION BAR, LH	1	V3-SP-21
9	ROLLSTOP ACTUATOR, LH	1	V1-PF-003
10	ROLLSTOP	1	22280
11	PIN, CLEVIS, 5/16X1-1¼ (BAG OF 10)	2	19513
12	TORSION BAR, RH	1	V3-SP-22
13	ROLLSTOP ACTUATOR, RH	1	V1-PF-002
14	KIT, LINK ASSY (GREY) & BRKTS (GREY), SHORTARM (left & right included in kit) For serial numbers 169180 and above	1	32824
	For serial numbers below 169180	1	23359
15	ROLLSTOP ASSY, INBOARD	1	V1-PF-212
16	CATCH, BASE LATCH	1	V2-AC-103
17	KIT, BRKTS, W/CAM FOLLOWER (left & right included in kit) For serial numbers 169180 and above	1	31247
	For serial numbers below 169180	1	23386
18	LINK ASSY, FRONT PLATFORM	2	29222
19	WASHER, DELRIN, 1" ODX.38 ID, 0.031 THK (BAG OF 10)	8	25628
20	KIT, COLLAR, ROLLSTOP ACTUATOR, 6.25", W/HDWR	1	28775
21	KIT, FLANGED BEARING, 1" ID, KIT OF 10	2	19579
22	BLOCK, PLATFORM LEVEL ADJ	2	VT-AH-142
23	SCREW, BUTTON HEAD, 5/16-18X ½, SST, BLK OX (BAG OF 10)	2	14484
24	SCREW, HEX HEAD, 5/16-18X 1 ½, GR5 (BAG OF 10)	2	14403
25	SETSCREW, ½-20X1¼, W/NYLON INSERT (BAG OF 10)	2	19704
26	KIT, HINGE, W/HDWR	3	14352
27	BUSHING, .392 ID, BRONZE	2	V2-BU-195
28	SCREW, BUTTON HEAD, 5/16-18X ¾, SST, BLK OX (BAG OF 10)	6	15983
29	WASHER, FLAT, .28X.62X.06 (BAG OF 10)	2	17504
30	BUSHING, STEEL, .25 ID X .32 OD X .19L	2	V2-BU-003
31	SPACER, .25ID X .40 ODX .2	2	UV-PF-839
32	NUT, W/NYLON INSERT, ¼-20 (BAG OF 10)	2	15919
33	NUT, W/NYLON INSERT, 5/16-18, SST (BAG OF 10)	9	14415
34	SCREW, HEX HEAD, ¼-20 X ¾, GR5 (BAG OF 10)	2	13308
35	SCREW, HEX HEAD, ¼-20 X ½, GR5 (BAG OF 10)	2	34518

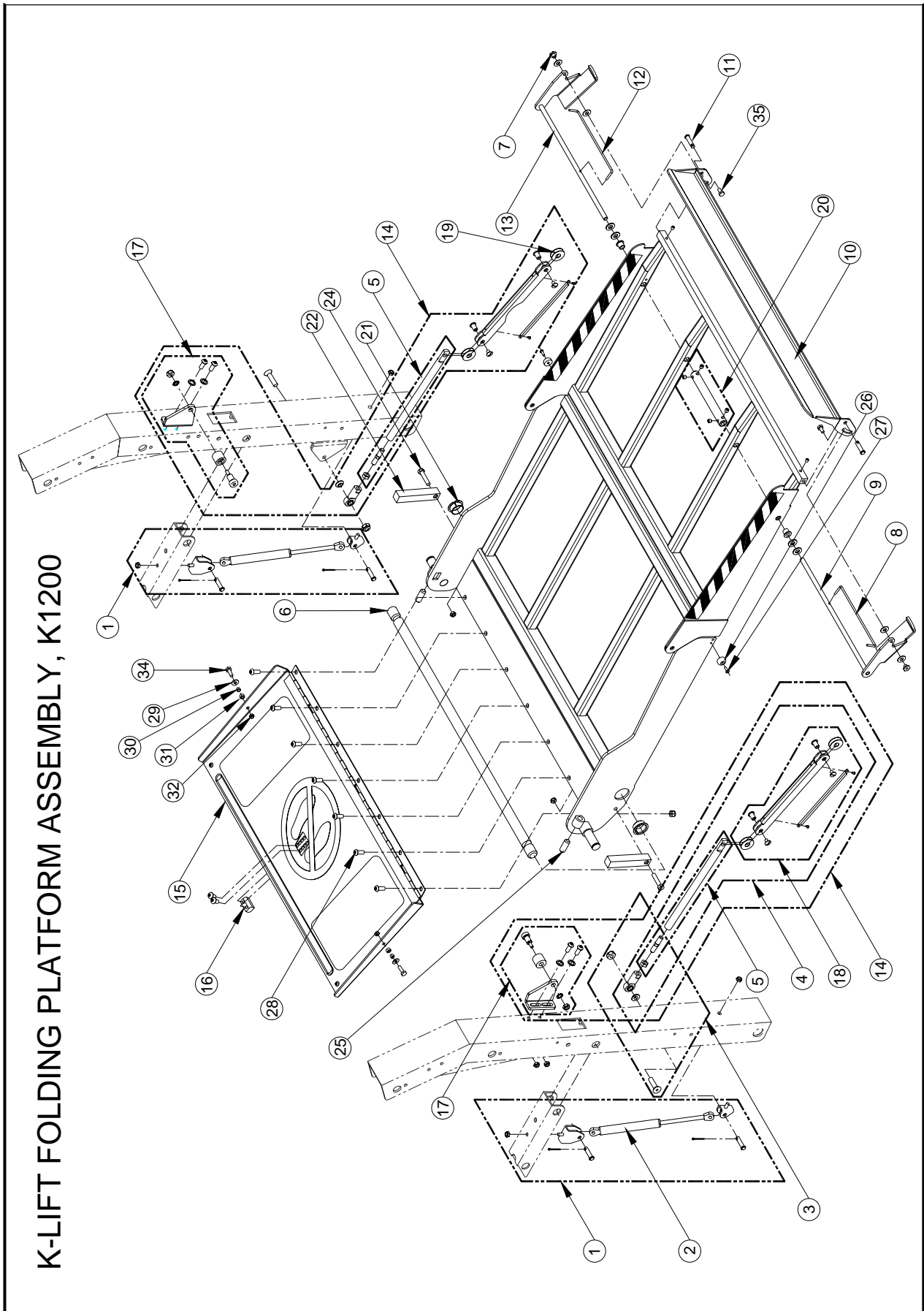
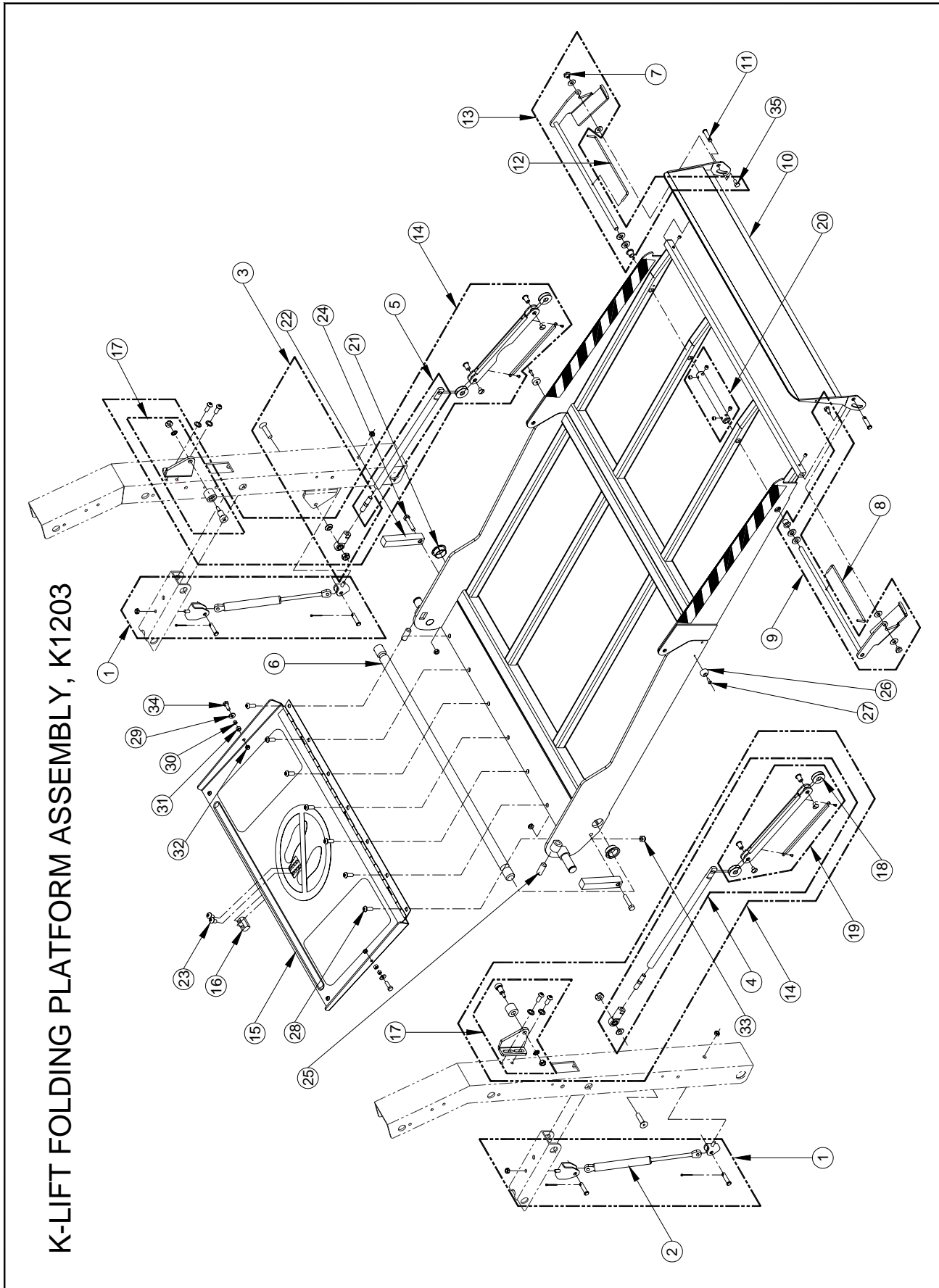

FIGURE 4-6: FOLDING PLATFORM ASSEMBLY, K1200

FIGURE 4-6: FOLDING PLATFORM ASSEMBLY, K1200

REF NO.	DESCRIPTION	QTY	PART
1	KIT, PNEUMATIC SPRING, RETROFIT (left & right included in kit)	2	19318
2	SPRING, PNEUMATIC ASSIST	2	R5-SP-502
3	ROD END ASSY, W/HDWR	2	29224
4	KIT, LINK ASSY	2	19507
5	KIT, LINK ASSY, REAR FOLDING PLATFORM (left & right included in kit)	1	29242
6	MAIN SHAFT, 1" DIA X 36.50"	1	VT-PI-43
7	T-NUT, ¼-20, SST (BAG OF 10)	2	14485
8	TORSION SPRING, LH	1	V3-SP-21
9	ACTUATOR, ROLLSTOP, LH	1	V2-FL-95
10	ROLLSTOP ASSY, 4"X30"	1	V2-PF-160
11	PIN, CLEVIS, 5/16X1-1/4 (BAG OF 10)	2	19513
12	TORSION SPRING, RH	1	V3-SP-22
13	ACTUATOR, ROLLSTOP, RH	1	V2-FL-94
14	KIT, LINK (YEL) & BRKTS (GRAY), HIGH MOUNT (left & right included in kit) For serial numbers 169180 and above	1	31250
	For serial numbers below 169180	1	23360
15	ROLLSTOP ASSY, INNER, 30"	1	V2-PF-141
16	CATCH, BASE LATCH	1	V2-AC-103
17	KIT, BRKTS (GRAY), HIGH MOUNT (left & right included in kit) For serial numbers 169180 and above	1	31251
	For serial numbers below 169180	1	23339
18	LINK ASSY, FRONT PLATFORM	1	29222
19	WASHER, DELRIN, 1"ODX.38IDX.03 THK (BAG OF 10)	8	25628
20	KIT, COLLAR, ROLLSTOP ACTUATOR, 6.25", W/HDWR	1	28775
21	KIT, FLANGED BEARING, 1" ID (KIT OF 10)	2	19579
22	BLOCK, PLATFORM LEVEL ADJ	2	VT-AH-142
23	SCREW, BUTTON HEAD, 5/16-18X1/2, SST, BLK OX (BAG OF 10)	2	14484
24	SCREW HEX HEAD, 5/16-18X 1½, GR5 (BAG OF 10)2	14403	
25	SETSCREW, ½-20X1/4, W/NYLON INSERT (BAG OF 10)	2	19704
26	BUMPER, VHMW, .75DX.38T	2	V2-AC-027
27	SCREW, PANHEAD, #8TEK X ½ (BAG OF 10)	2	15961
28	SCREW, BUTTON HEAD, 5/16-18 X ¾, SST, BLK OX (BAG OF 10)	7	15983
29	WASHER, FLAT, .281 X .625 X .065 (BAG OF 10)	2	17504
30	BUSHING STEEL, .25ID X .32OD X.19L	2	V2-BU-003
31	SPACER, .25ID X .40OD X .2	2	UV-PF-839
32	NUT, NYLON INSERT, ¼-20 (BAG OF 10)	2	15919
33	NUT, NYLON INSERT, 5/16-18, SST (BAG OF 10)	7	14415
34	SCREW, HEX HEAD, ¼-20 X ¾, GR5 (BAG OF 10)	2	13308
35	SCREW, HEX HEAD, ¼-20 X ½, GR5 (BAG OF 10)	2	34518



K-LIFT FOLDING PLATFORM ASSEMBLY, K1203

FIGURE 4-7: FOLDING PLATFORM ASSEMBLY, K1203



FIGURE 4-7: FOLDING PLATFORM ASSEMBLY, K1203

REF	DESCRIPTION	QTY	PART NO.
1	KIT, PNEUMATIC SPRING ASSY, RETROFIT (left & right included in kit)	2	19318
2	SPRING, PNEUMATIC ASSIST	2	R5-SP-502
3	ROD END ASSY, W/HDWR	2	29224
4	KIT, LINK ASSY	2	19522
5	KIT, LINK ASSY, REAR FOLDING PLATFORM (left & right included in kit)	1	29243
6	MAIN SHAFT, 1" DIA X 36.50"	1	VT-PI-43
7	T-NUT, ¼-20, SST (BAG OF 10)	2	14485
8	TORSION SPRING, LH	1	V2-SP-021
9	KIT, ACTUATOR, ROLLSTOP REPLACEMENT, LH	1	22903
10	ROLLSTOP ASSY, 6"X30"	1	V2-PF-291
11	PIN, CLEVIS, 5/16X1-1/4 (BAG OF 10)	2	19513
12	TORSION SPRING, RH	1	V2-SP-022
13	KIT, ACTUATOR, ROLLSTOP REPLACEMENT, RH	1	22902
14	KIT, LINK (YEL) & BRKTS (GREY) RH & LH (serial # 169180 & above)	1	31253
	KIT, LINK (GREY) & BRKTS (GREY) RH & LH (serial # 169180 & above)	1	31254
	KIT, LINK & BRACKETS, W/ROLLER RH & LH (serial #'s below 169180)	1	23357
15	ROLLSTOP ASSY, INNER, 30" PLATFORM	1	V2-PF-141
16	CATCH, BASE LATCH	1	V2-AC-103
17	KIT, BRKTS W/ROLLER (left and right included in kit)		
	For serial numbers 169180 & above	1	31252
	For serial numbers below 169180	1	23356
18	WASHER, DELRIN, 1" ODX .388ID, 0.03 THK (BAG OF 10)	8	25628
19	LINK ASSY, FRONT PLATFORM	2	29223
20	KIT, COLLAR ROLLSTOP ACTUATOR 6.25", W/HDWR	1	28775
21	KIT, FLANGED BEARING, 1" ID, KIT OF 10	2	19579
22	BLOCK, PLATFORM LEVEL ADJ	2	VT-AH-142
23	SCREW, BUTTON HEAD, 5/16-18X1/2, SST, BLK OX (BAG OF 10)	2	14484
24	SCREW, HEX HEAD, 5/16-18X 1½, GR5 (BAG OF 10)	2	14403
25	SETSCREW, ½-20X1/4, W/NYLON INSERT (BAG OF 10)	2	19704
26	BUMPER, VHMW, .75DX.38T	2	V2-AC-027
27	SCREW, PAN HEAD, #8TEK X ½ (BAG OF 10)	2	15961
28	SCREW, BUTTON HEAD, 5/16-18 X ¾ SST, BLK OX (BAG OF 10)	7	15983
29	WASHER, FLAT, .281 X .625 X .065 (BAG OF 10)	2	17504
30	BUSHING STEEL, .25ID X .32OD X.19L	2	V2-BU-003
31	SPACER, .25ID X .40OD X .2	2	UV-PF-839
32	NUT, W/NYLON INSERT, ¼-20 (BAG OF 10)	2	15919
33	NUT, W/NYLON INSERT, 5/16-18, SST (BAG OF 10)	7	14415
34	SCREW, HEX HEAD, ¼-20 X ¾ GR5 (BAG OF 10)	2	13308
35	SCREW, HEX HEAD, ¼-20 X ½, GR5 (BAG OF 10)	2	34518

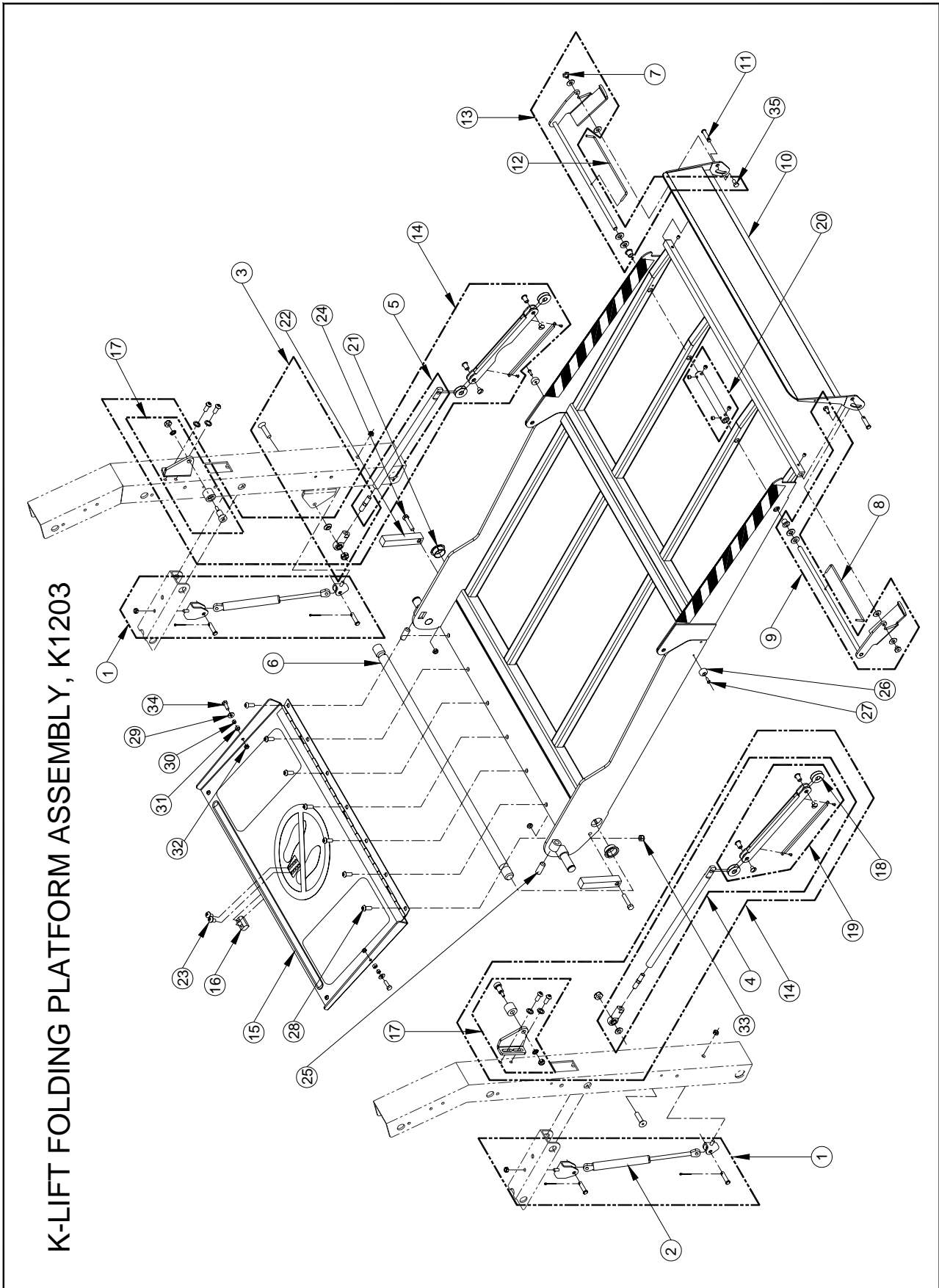

K-LIFT FOLDING PLATFORM ASSEMBLY, K1203

FIGURE 4-8: FOLDING PLATFORM ASSEMBLY, K1205

FIGURE 4-8: FOLDING PLATFORM ASSEMBLY, K1205

REF	DESCRIPTION	QTY	PART NO.
1	KIT, PNEUMATIC SPRING ASSY, RETROFIT (left & right included in kit)	2	19318
2	SPRING, PNEUMATIC ASSIST	2	R5-SP-502
3	ROD END ASSY, W/HDWR	2	29224
4	KIT, LINK ASSY	2	19523
5	KIT, LINK ASSY, REAR FOLDING PLATFORM (left & right included in kit)	1	29243
6	MAIN SHAFT, 1" DIA X 39.13"	1	VT-PI-49
7	T-NUT, ¼-20, SST (BAG OF 10)	2	14485
8	TORSION SPRING, LH	1	V2-SP-021
9	KIT, ACTUATOR, ROLLSTOP REPLACEMENT, LH	1	22903
10	ROLLSTOP ASSY, 6"X32"	1	V2-PF-292
11	PIN, CLEVIS, 5/16X1-1/4 (BAG OF 10)	2	19513
12	TORSION SPRING, RH	1	V2-SP-022
13	KIT, ACTUATOR, ROLLSTOP REPLACEMENT, RH	1	22902
14	KIT, LINK (YEL) & BRKTS (GREY) RH & LH (serial #'s 169180 & above)	1	31253
	KIT, LINK (GREY) & BRKTS (GREY) RH & LH (serial #'s 169180 & above)	1	31254
	KIT, LINK (GREY) & BRKTS (GREY) RH & LH (serial #'s below 169180)	1	23358
15	ROLLSTOP ASSY, INNER	1	V2-PF-142
16	CATCH, BASE LATCH	1	V2-AC-103
17	KIT, BRACKETS W/ROLLER (left and right included in kit)		
	For serial #'s 169180 and above	1	31252
	For serial #'s below 169180	1	23356
18	WASHER, DELRIN, 1" ODX.38IDX.03 THK (BAG OF 10)	8	25628
19	LINK ASSY, FRONT PLATFORM	2	29222
20	KIT, COLLAR ROLLSTOP ACTUATOR, 6.25", W/HDWR	1	28775
21	KIT, FLANGED BEARING, 1" ID KIT OF 10	2	19579
22	BLOCK, PLATFORM LEVEL ADJ	2	VT-AH-142
23	SCREW, BUTTON HEAD, 5/16-18X1/2, SST, BLK OX (BAG OF 10)	2	14484
24	SCREW HEX HEAD, 5/16-18X1½, GR5 (BAG OF 10)	2	14403
25	SETSCREW, ½-20X1/4, W/NYLON INSERT (BAG OF 10)	2	19704
26	BUMPER, VHMW, .75DX.38T	2	V2-AC-027
27	SCREW, PAN HEAD, #8TEK X ½ (BAG OF 10)	2	15961
28	SCREW, BUTTON HEAD, 5/16-18 X ¾ SST, BLK OX (BAG OF 10)	7	15983
29	WASHER, FLAT, .28 X .625 X .065 (BAG OF 10)	2	17504
30	BUSHING STEEL, .25ID X .32OD X .19L	2	V2-BU-003
31	SPACER, .25ID X .40OD X .2	2	UV-PF-839
32	NUT, W/NYLON INSERT, ¼-20 (BAG OF 10)	2	15919
33	NUT, W/NYLON INSERT, 5/16-18, SST (BAG OF 10)	7	14415
34	SCREW HEX HEAD, ¼-20 X ¾, GR5 (BAG OF 10)	2	13308
35	SCREW, HEX HEAD, ¼-20 X ½, GR5 (BAG OF 10)	2	34518

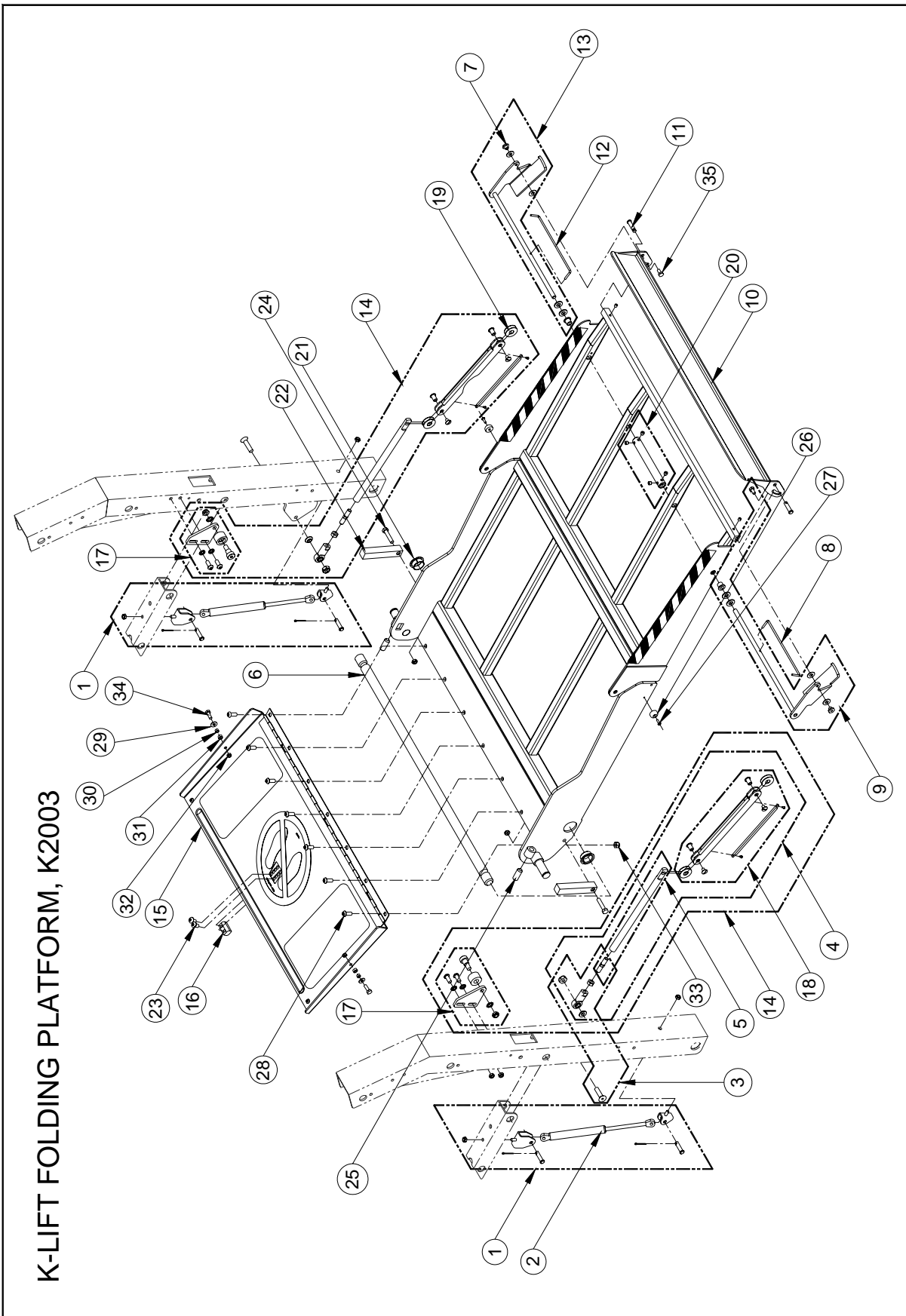

FIGURE 4-9: FOLDING PLATFORM ASSEMBLY, K2003

FIGURE 4-9: FOLDING PLATFORM ASSEMBLY, K2003

REF	DESCRIPTION	QTY	PART NO.
1	KIT, PNEUMATIC SPRING ASSY, RETROFIT (left & right)	2	19318
2	SPRING, PNEUMATIC ASSIST	2	R5-SP-502
3	ROD END ASSY, W/HDWR	2	29224
4	KIT, LINK ASSY	2	19522
5	KIT, LINK ASSY, REAR FOLDING PLATFORM (left & right)	1	29243
6	MAIN SHAFT, 1" DIA X 36.50"	1	VT-PI-43
7	T-NUT, ¼-20, SST (BAG OF 10)	2	14485
8	TORSION SPRING, LH	1	V2-SP-021
9	KIT, ACTUATOR, ROLLSTOP REPLACEMENT, LH	1	22903
10	ROLLSTOP ASSY, 6"X30"	1	V2-PF-291
11	PIN, CLEVIS, 5/16X1-1/4 (BAG OF 10)	2	19513
12	TORSION SPRING, RH	1	V2-SP-022
13	KIT, ACTUATOR, ROLLSTOP REPLACEMENT, RH	1	22902
14	KIT, LINK (YEL) & BRKTS (GREY) (right & left) serial #'s 169180 & above	1	31246
	KIT, LINK (RED) & BRKTS (RED) (right & left) serial #'s 169180 & above	1	31246R
	KIT, LINK (YEL) & BRKTS (YEL) (right & left) serial #'s 169180 & above	1	31246Y
	KIT, LINK & BRKTS (right & left) serial #'s below 169180	1	23338
15	ROLLSTOP ASSY, INNER, 30" PLATFORM	1	V2-PF-141
16	CATCH, BASE LATCH	1	V2-AC-103
17	KIT, BRACKET W/CAM FOLLOWER (left and right included in kit)		
	For serial #'s 169180 and above	1	31247
	For serial #'s below 169180	1	23339
18	LINK ASSY, FRONT PLATFORM	2	29223
19	WASHER, DELRIN, 1" ODX.38IDX.03 THK (BAG OF 10)	8	25628
20	KIT, COLLAR ROLLSTOP ACTUATOR, 6.25", W/HDWR	1	28775
21	KIT, FLANGED BEARING, 1" ID, KIT OF 10	2	19579
22	BLOCK, PLATFORM LEVEL ADJ	2	VT-AH-142
23	SCREW, BUTTON HEAD, 5/16-18X1/2, SST, BLK OX (BAG OF 10)	2	14484
24	SCREW, HEX HEAD, 5/16-18X 1 ½ GR5 (BAG OF 10)	2	14403
25	SETSCREW, ½-20X1/4, W/NYLON INSERT (BAG OF 10)	2	19704
26	BUMPER, VHMW, .75DX.38T	2	V2-AC-027
27	SCREW, PAN HEAD, #8TEK X ½ (BAG OF 10)	2	15961
28	SCREW, BUTTON HEAD, 5/16-18 X ¾ SST, BLK OX (BAG OF 10)	7	15983
29	WASHER, FLAT, .28 X .625 X .065 (BAG OF 10)	2	17504
30	BUSHING, STEEL, .25ID X .32OD X.19L	2	V2-BU-003
31	SPACER, .25ID X .40OD X .2	2	UV-PF-839
32	NUT, W/NYLON INSERT, ¼-20 (BAG OF 10)	2	15919
33	NUT, W/NYLON INSERT, 5/16-18,SST (BAG OF 10)	7	14415
34	SCREW, HEX HEAD, ¼-20 X ¾ GR5 (BAG OF 10)	2	13308
35	SCREW, HEX HEAD, ¼-20 X ½, GR5 (BAG OF 10)	2	34518

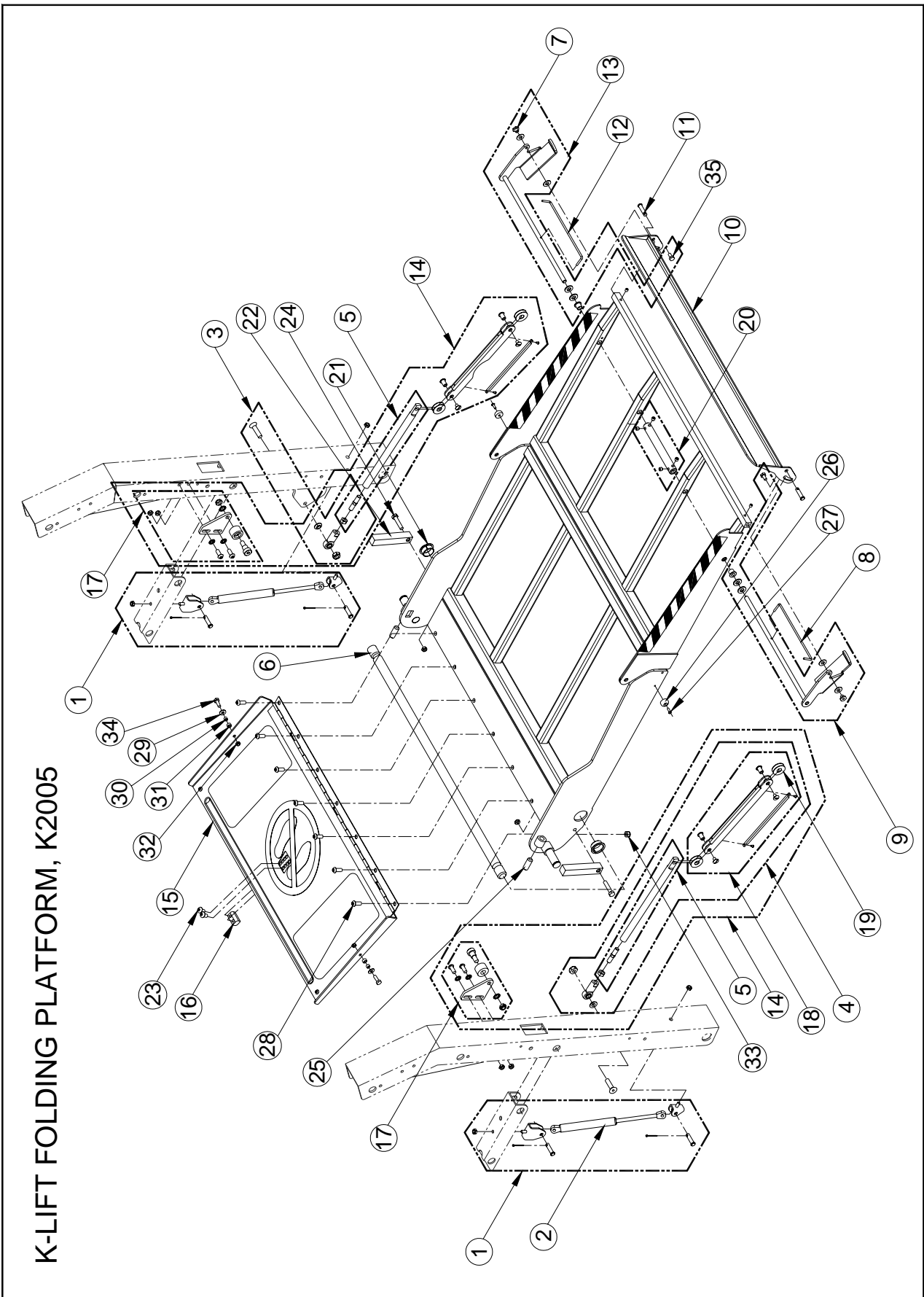

FIGURE 4-10: FOLDING PLATFORM ASSEMBLY, K2005

FIGURE 4-10: FOLDING PLATFORM ASSEMBLY, K2005

REF	DESCRIPTION	QTY	PART NO.
1	KIT, PNEUMATIC SPRING ASSY, RETROFIT (left & right included in kit)	1	19318
2	SPRING, PNEUMATIC ASSIST	2	R5-SP-502
3	ROD END ASSY, W/HDWR	2	29224
4	KIT, LINK ASSY	2	19522
5	KIT, LINK ASSY, REAR FOLDING PLATFORM (left & right included in kit)	1	29243
6	MAIN SHAFT, 1" DIA X 39.13"	1	VT-PI-49
7	T-NUT, ¼-20, SST (BAG OF 10)	2	14485
8	TORSION SPRING, LH	1	V2-SP-021
9	KIT, ACTUATOR, ROLLSTOP REPLACEMENT, LH	1	22903
10	ROLLSTOP ASSY, 6"X32"	1	V2-PF-292
11	PIN, CLEVIS, 5/16X1-1/4 (BAG OF 10)	2	19513
12	TORSION SPRING, RH	1	V2-SP-022
13	KIT, ACTUATOR, ROLLSTOP REPLACEMENT, RH	1	22902
14	KIT, LINK (YEL) & BRKTS (GREY) (right & left) serial #'s 169180 & above	1	31246
	KIT, LINK (RED) & BRKTS (RED) (right & left) serial #'s 169180 & above	1	31246R
	KIT, LINK (YEL) & BRKTS (YEL) (right & left) serial #'s 169180 & above	1	31246Y
	KIT, LINK & BRKTS (right & left) serial #'s below 169180	1	23338
15	ROLLSTOP ASSY, INNER	1	V2-PF-142
16	CATCH, BASE LATCH	1	V2-AC-103
17	KIT, BRACKETS W/CAM FOLLOWER (left & right included in kit)		
	For serial numbers 169180 and above	1	31247
	For serial numbers below 169180	1	23339
18	LINK ASSY, FRONT PLATFORM	2	29223
19	WASHER, DELRIN, 1" ODX.38ID, .03 THK (BAG OF 10)	8	25628
20	KIT, COLLAR ROLLSTOP ACTUATOR 6.25", W/HDWR	1	28775
21	KIT, FLANGED BEARING, 1" ID, KIT OF 10	2	19579
22	BLOCK, PLATFORM LEVEL ADJ	2	VT-AH-142
23	SCREW, BUTTON HEAD, 5/16-18X1/2 SST, BLK OX (BAG OF 10)	2	14484
24	SCREW, HEX HEAD, 5/16-18X1½ GR5 (BAG OF 10)	2	14403
25	SETSCREW, ½-20X1/4 W/NYLON INSERT (BAG OF 10)	2	19704
26	BUMPER, VHMW, .75DX.38T	2	V2-AC-027
27	SCREW, PAN HEAD, #8TEK X ½ (BAG OF 10)	2	15961
28	SCREW, BUTTON HEAD, 5/16-18 X ¾ SST, BLK OX (BAG OF 10)	7	15983
29	WASHER, FLAT, .28 X .625 X .065 (BAG OF 10)	2	17504
30	BUSHING, STEEL, .25ID X .32OD X.19L	2	V2-BU-003
31	SPACER, .25ID X .40OD X .2	2	UV-PF-839
32	NUT, W/NYLON INSERT, ¼-20 (BAG OF 10)	2	15919
33	NUT, W/NYLON INSERT, 5/16-18, SST (BAG OF 10)	7	14415
34	SCREW, HEX HEAD, ¼-20 X ¾ GR5 (BAG OF 10)	2	13308
35	SCREW, HEX HEAD, ¼-20 X ½, GR5 (BAG OF 10)	2	34518

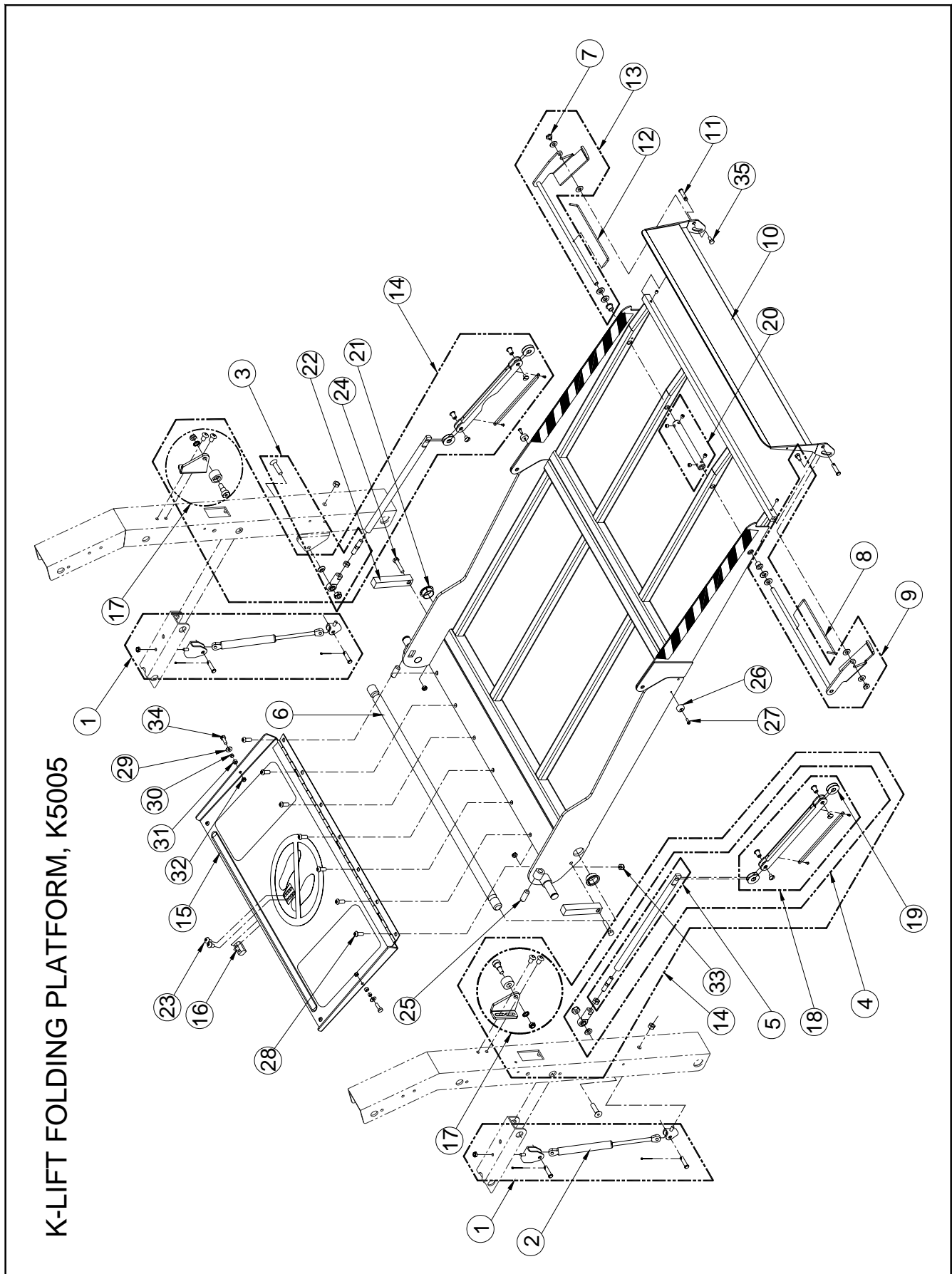

FIGURE 4-11: FOLDING PLATFORM ASSEMBLY, K5005



FIGURE 4-11: FOLDING PLATFORM ASSEMBLY, K5005/K5510

REF NO.	DESCRIPTION	QTY	PART
1	KIT, PNEUMATIC SPRING ASSY, RETROFIT (left & right)	1	19318
2	SPRING, PNEUMATIC ASSIST	2	R5-SP-502
3	ROD END ASSY, W/HDWR	2	29224
4	KIT, LINK ASSY	2	19522
5	KIT, LINK ASSY, REAR FOLDING PLATFORM (left & right)	1	29243
6	MAIN SHAFT, 1" DIA X 39.13"	1	VT-PI-49
6-1	KIT, SHAFT, MAIN, 1.00" X 40.50"L	1	34887
7	T-NUT, ¼-20, SST (BAG OF 10)	2	14485
8	TORSION SPRING, LH	1	V2-SP-021
9	KIT, ACTUATOR, ROLLSTOP REPLACEMENT, LH	1	22903
10	ROLLSTOP ASSY, 6"X32"	1	V2-PF-292
10-1	ROLLSTOP ASSY, 6" X 34"W, OUTBOARD	1	16626
11	PIN, CLEVIS, 5/16X1-1/4 (BAG OF 10)	2	19513
12	TORSION SPRING, RH	1	V2-SP-022
13	KIT, ACTUATOR, ROLLSTOP REPLACEMENT, RH	1	22902
14	KIT, LINK (YEL) & BRKTS (GREY), HIGH MOUNT (left & right included in kit) For serial numbers 169180 and above	1	31250
	For serial numbers below 169180	1	23340
15	ROLLSTOP ASSY, INNER, 30" PLATFORM	1	V2-PF-141
15-1	BRIDGEPLATE ASSY	1	30869
16	CATCH, BASE LATCH	1	V2-AC-103
17	KIT, BRACKETS (GREY), HIGH MOUNT W/CAM FOLLOWER (left & right included in kit) For serial numbers 169180 and above	1	31251
	For serial numbers below 169180	1	23355
17-1	KIT, BRACKETS (GRAY), HIGH MOUNT, LH & RH	2	23355
18	LINK ASSY, FRONT PLATFORM	2	29223
19	WASHER, DELRIN, 1" ODX.38ID, .03 THK (BAG OF 10)	8	25628
20	KIT, COLLAR ROLLSTOP ACTUATOR, 6.25", W/HDWR	1	28775
21	KIT, FLANGED BEARING, 1" ID, KIT OF 10	2	19579
21-1	KIT, FLANGED BEARING, ¾" ID, KIT OF 10	2	19576
22	BLOCK, PLATFORM LEVEL ADJ	2	VT-AH-142
23	SCREW, BUTTON HEAD, 5/16-18X1/2, SST, BLK OX (BAG OF 10)	2	14484
24	SCREW, HEX HEAD, 5/16-18X1½, GR5 (BAG OF 10)	2	14403
25	SETSCREW, ½-20X1/4 W/NYLON INSERT (BAG OF 10)	2	19704
26	BUMPER, VHMW, .75DX.38T	2	V2-AC-027
27	SCREW, PAN HEAD, #8TEK X ½ (BAG OF 10)	2	15961
28	SCREW, BUTTON HEAD, 5/16-18 X ¾, SST, BLK OX (BAG OF 10)	7	15983
29	WASHER, FLAT, .28 X .625 X .065 (BAG OF 10)	2	17504
30	BUSHING, STEEL, .25ID X .32OD X.19L	2	V2-BU-003
31	SPACER, .25ID X .40OD X .2	2	UV-PF-839
32	NUT, W/NYLON INSERT, ¼-20 (BAG OF 10)	2	15919
33	NUT, W/NYLON INSERT, 5/16-18, SST (BAG OF 10)	7	14415
34	SCREW, HEX HEAD, ¼-20 X ¾, GR5 (BAG OF 10)	2	13308
35	SCREW, HEX HEAD, ¼-20 X ½, GR5 (BAG OF 10)	2	34518

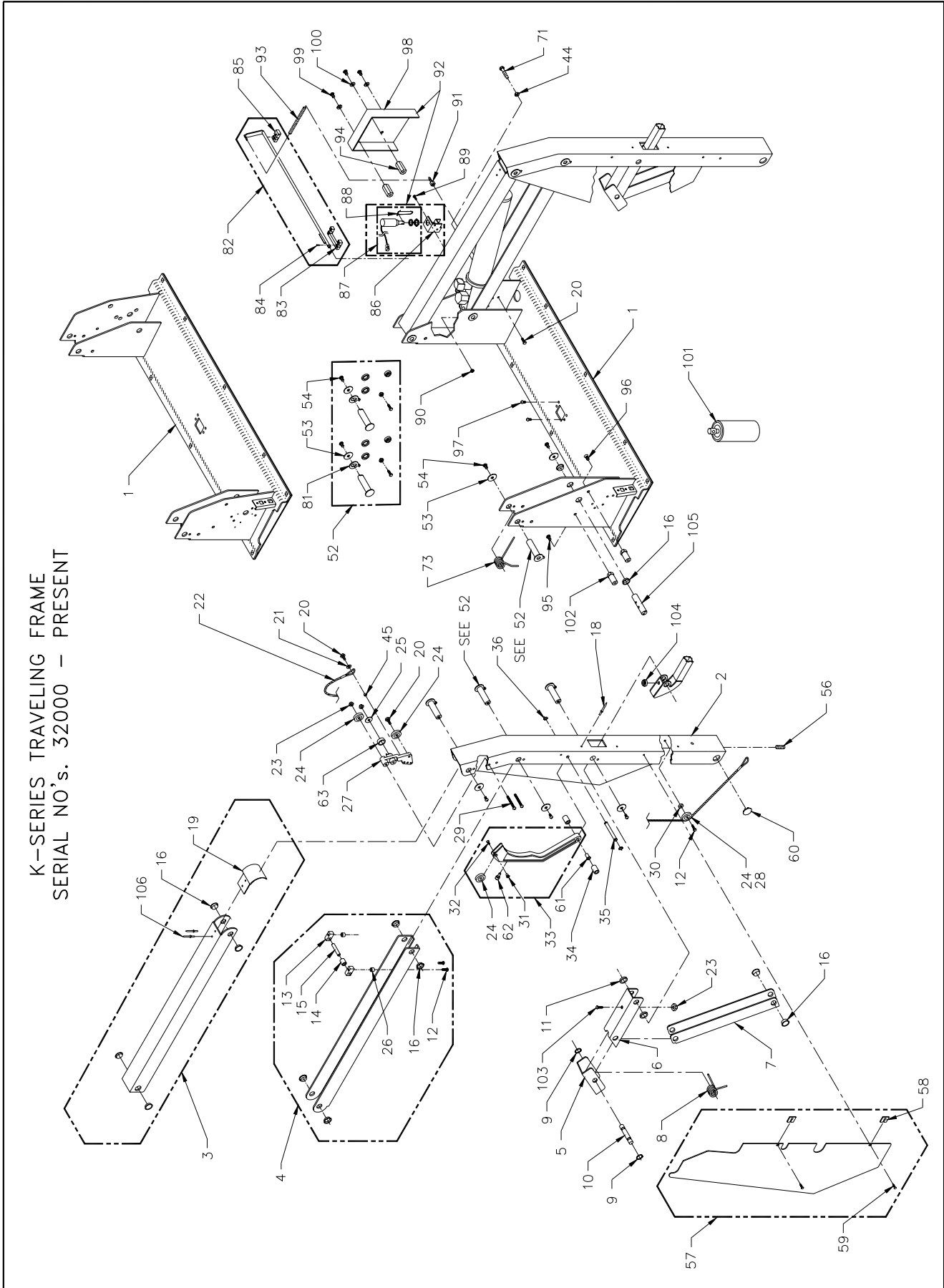

FIGURE 4-12: TRAVELING FRAME

FIGURE 4-12: TRAVELING FRAME

REF	DESCRIPTION	QTY	PART NO
1-1	BASEPLATE ASSY, 30", w/o INTERLOCK	1	14452
	BASEPLATE ASSY, 30", w/o INTERLOCK, RH	1	14452R
	BASEPLATE ASSY, 30", w/INTERLOCK	1	14453
1-2	BASEPLATE ASSY, 32", w/o INTERLOCK	1	14454
	BASEPLATE ASSY, 32" ,w/o INTERLOCK, RH	1	14454R
	BASEPLATE ASSY, 32" w/INTERLOCK	1	14455
1-3 *	<b>BASEPLATE WLDT</b>	<b>1</b>	<b>16618</b>
2-1	VERTICAL ARM ASSY, RH, K1100	1	21604
	VERTICAL ARM ASSY, LH, K1100	1	21605
2-1	VERTICAL ARM ASSY, RH, K1200	1	15167
	VERTICAL ARM ASSY, LH, K1200	1	15166
2-2	VERTICAL ARM ASSY, K2000, RH	1	19328
	VERTICAL ARM ASSY, K2000, LH	1	19327
2-3	VERTICAL ARM ASSY, K5000, RH	1	22292
	VERTICAL ARM ASSY, K5000, LH	1	22293
2-4	<b>VERTICAL ARM ASSY, K55XX, RH</b>	<b>1</b>	<b>30850</b>
	<b>VERTICAL ARM ASSY, K55XX, LH</b>	<b>1</b>	<b>30854</b>
3-1	TOP ARM ASSY, K1100/K1200	2	VS-AC-250
3-2	TOP ARM ASSY, K2000	2	VT-AC-250
3-3	TOP ARM ASSY, K5000	2	V5-AC-250
3-4	<b>TOP ARM ASSY, K55XX</b>	<b>2</b>	<b>30858</b>
4-1	BOTTOM ARM ASSY, K1200	2	VS-AC-252
4-2	BOTTOM ARM ASSY, K2000	2	VT-AC-252
4-3	BOTTOM ARM ASSY, K5000	2	V5-AC-252
4-4	<b>BOTTOM ARM ASSY, K55XX</b>	<b>2</b>	<b>30835</b>
5	SADDLE ASSEMBLY	2	VT-AC-046
6	LINK, UPPER KNUCKLE LEVER ASSY	2	VT-AC-070
7-1	LINK, VERTICAL KNUCKLE ASSY, W/LOAD SENSOR K1200	1	VS-AC-058
7-2	LINK, VERTICAL KNUCKLE ASSY, W/LOAD SENSOR K2000	1	VT-AC-058
7-3	LINK, VERTICAL KNUCKLE ASSY, W/LOAD SENSOR K5000	1	V5-AC-058
7-4	LINK, VERTICAL KNUCKLE ASSY, K1100, W/O LOAD SENSOR	1	V1-AC-069
7-5	LINK, VERTICAL KNUCKLE ASSY, K1200, W/O LOAD SENSOR	2	VS-AC-069
7-6	LINK, VERTICAL KNUCKLE ASSY, K2000, W/O LOAD SENSOR	2	VT-AC-069
7-7	LINK, VERTICAL KNUCKLE ASSY, K5000, W/O LOAD SENSOR	2	V5-AC-069
7-8	<b>KIT, KNUCKLE LEVER ASSY, K55XX, W/O LOAD SENSOR</b>	<b>2</b>	<b>34894</b>
8	SPRING, KNUCKLE ACTUATOR	2	VT-SP-42
9	RETAINING RING, .75" EXT (BAG OF 10)	1	11796
10	PIN, SNAP RING, .75 OD X 2.15L	2	VT-PI-41
11	SPACER, KNUCKLE LINK	4	VT-BU-42
12	SCREW, BUTTON HEAD, 1/4-20 X 1", SST (BAG OF 10)	6	19715
13	RETAINER, CAM ROLLER	4	V2-AC-025
14-1	ROLLER, INNER ROLLSTOP CAM (K2000 & K5000)	2	V2-AC-124
14-2	ROLLER, INNER ROLLSTOP CAM (K1000 & K1200)	2	V2-AC-024
15	PIN, CAM ROLLER	2	V2-PI-094
16	FLANGED BUSHING, .75ID, (BAG OF 10)	3	19576
18	RIVET, BLIND, 3/16 X 1/2", ALUM, (BAG OF 10)	10	15918
19	CAP, UPPER PARALLEL ARM	2	V2-AC-89
20-1	SCREW, HEX HEAD, 1/4-20 x 3/4, GR5, (BAG OF 10)	4	13308
20-2	SCREW, FLAT HEAD, 1/4-20 x 1/2, (BAG OF 10)	1	15928

REF	DESCRIPTION	QTY	PART NO
21	WASHER, FLAT, .63OD x .28ID x .065, (BAG OF 10)	2	17504
22-1	CABLE ASSY, REPLACEMENT, IRS, K1100	1	13661
22-2	CABLE ASSY, REPLACEMENT, IRS, K1200	1	16093
22-3	CABLE ASSY, REPLACEMENT, IRS, K2000	1	16094
22-4	CABLE ASSY, REPLACEMENT, IRS, K5000	1	16095
22-5	KIT, CABLE ASSY W/SLEEVE, K55XX SERIES	2	34247
23	NUT, HEX ¼-20, W/NYLON INSERT (BAG OF TEN)	1	15919
24	BEARING, GROOVED	8	VS-AH-06
25	WASHER, FENDER, ¼"X1" OD, (BAG OF TEN)	2	25623
26	STAND-OFF, .38LG, ¼"IDX½"OD	4	V2-AC-011
27	BLOCK, PULLEY MOUNT, INNER ROLLSTOP	2	V2-AC-112
28	BEARING, 1" OD, GROOVED, .25ID, S1100	2	25374
29	SCREW, BUTTON HEAD, 1/4-20 x 2 1/4, SST, BLK OXIDE, (BAG OF 10)	1	19720
30	BUSHING, 5/8 OD X 3/16L	2	VS-AH-13
31	T-NUT, FLAT HEAD, 10-24 X .25 OD X .44L	2	V2-AC-015
32	SCREW, FLAT HEAD, 10-24 x ½, (BAG OF 10)	1	13303
33	CAM ASSY, INNER ROLLSTOP ACTUATOR	2	V2-AC-190
34	KIT, SPACER, RUBBER, INNER ROLLSTOP CAM (KIT OF 4)	4	01224
35	PIN, SNAP RING, .38OD X 3.09L	2	VS-PI-09
36	RETAINING RING, .38ID, (BAG OF 10)	1	11795
45	BUSHING, STEEL, 251D X 320D X .19L	2	V2-BU-003
52	KIT (RETROFIT), PIN, LINK, ARM ASSY	3	16679
53	WASHER, FENDER, 5/16, SST, (BAG OF TEN)	1	15921
54	SCREW, BUTTON HEAD, 5/16-18X½, SST, (BAG OF TEN)	1	14494
56	SET SCREW, 3/8-16X3/8", CUP POINT	4	11797
57	SEE FIGURE 4-13 "PINCH POINT SHIELDS"		
58	SPRING NUT, 10-24, U-TYPE, (BAG OF 10)	1	11799
59	SCREW, PAN HEAD, 10-24 x ½, (BAG OF 10)	1	13304
60	PLUG, 1" LOW PROFILE, BLK NYLON	2	25563
61	BEARING, NYLINER, 3/8 IDX11/16 LONG	2	25562
62	BUMPER, BUTTON, IRS CAM, (BAG OF 10)	1	19783
63	BUMPER, IRS CAM, ANTI-RATTLE	2	V2-BU-090
71	SCREW, HEX HEAD, 1/4-20 X 1-3/4, GR5 (BAG OF 10)	1	25696
73	SPRING, UPPER PARALLEL ARM	2	V2-SP-97
80	SETSCREW, 5/16-18 x 1, CUP PT, (BAG OF 10)	1	15830
81	WASHER, KEYED	2	20258
82-1	KIT, LATCH RELEASE, 26", w/BLOCKS & HDWR	1	28767
82-2	KIT, LATCH RELEASE, 30", w/BLOCKS & HDWR	1	28768
82-3	KIT, LATCH RELEASE, 32", w/BLOCKS & HDWR	1	28769
83	BLOCK, CENTER MOUNTING, BASE LATCH	1	V2-AC-102
84	DOWEL PIN, .094 DIA X .38 L, (BAG OF 10)	1	25615
85	BLOCK, MOUNTING, BASE LATCH	1	V2-AC-001
86	BRACKET, STOW LOCK SOLENOID	1	V2-AC-108
87-1	SOLENOID ASSY, 12V	1	V2-ES-127
87-2	SOLENOID ASSY, 24V	1	V2-ES-128
88	CLIP, SPRING, BASE LATCH	1	V2-AC-009
89	SCREW, FLAT HEAD, 10-24 x ½, SST, (BAG OF 10)	1	14426
90	NUT, HEX, NYLON INSERT, 10-24, (BAG OF 10)	1	13382
91	PIN, SPRING MOUNTING	1	V2-PI-095
92-1	KIT, REPLACEMENT SOLENOID, 12V (S/N's 32000 - 50516)	1	01238

REF	DESCRIPTION	QTY	PART NO
92-2	KIT, REPLACEMENT SOLENOID, 24V (S/N's 32000 - 50516)	1	01239
93	SPRING, DOOR HELPER .38ODX3.5"	1	V2-SP-093
94	BUSHING, LATCH COVER	2	V2-BU-080
95	SCREW, HEX HEAD, 5/16-18 X 3/4", (BAG OF 10)	1	15901
96	SCREW, FLAT HEAD, 5/16-18X <sup>3</sup> / <sub>4</sub> ", (BAG OF 10)	1	14499
97	SCREW, BUTTON HEAD, 1/4-20X1 <sup>1</sup> / <sub>2</sub> ", SST, (BAG OF 10)	1	15902
98	COVER, BASE LATCH	1	V2-CV-123
99	SCREW, HEX HEAD, 5/16-18X.625, (BAG OF 10)	1	14495
100	WASHER, FLAT, .69OD x .34ID x .065, (BAG OF 10)	1	13350
101	SPRAY PAINT, TOUCH-UP, CHARCOAL	1	25340
102	BUSHING, E-COVER MOUNT	2	V2-BU-081
103	SCREW, HEX HEAD, 1/4-20X1, GR5, (BAG OF 10)	1	14493
104	GROMMET, .30ID x .88OD x .44, (BAG OF 10)	1	23391
105	PIN, CONTROL CAM	1	V2-PI-091
106	RIVET, BLIND, 3/16ODX5/8L, STEEL (BAG OF 10)	4	34519
107**	COVER, PINCH POINT, 7"X12", PVC	2	V3-AC-26
108**	COVER, PINCH POINT, 3"X25", PVC	2	V3-AC-27
109**	COVER, PINCH POINT, 3"X29", PVC	4	V3-AC-28
110**	COVER, PINCH POINT, 3"X30", PVC	2	V3-AC-29
111**	COVER, PINCH POINT, 3"X5"X8", PVC	2	V3-AC-31

\* Item not shown

\*\* Item not shown: Part of the Articulating Pinch Point Set S20XX-XXXXXXX1X.

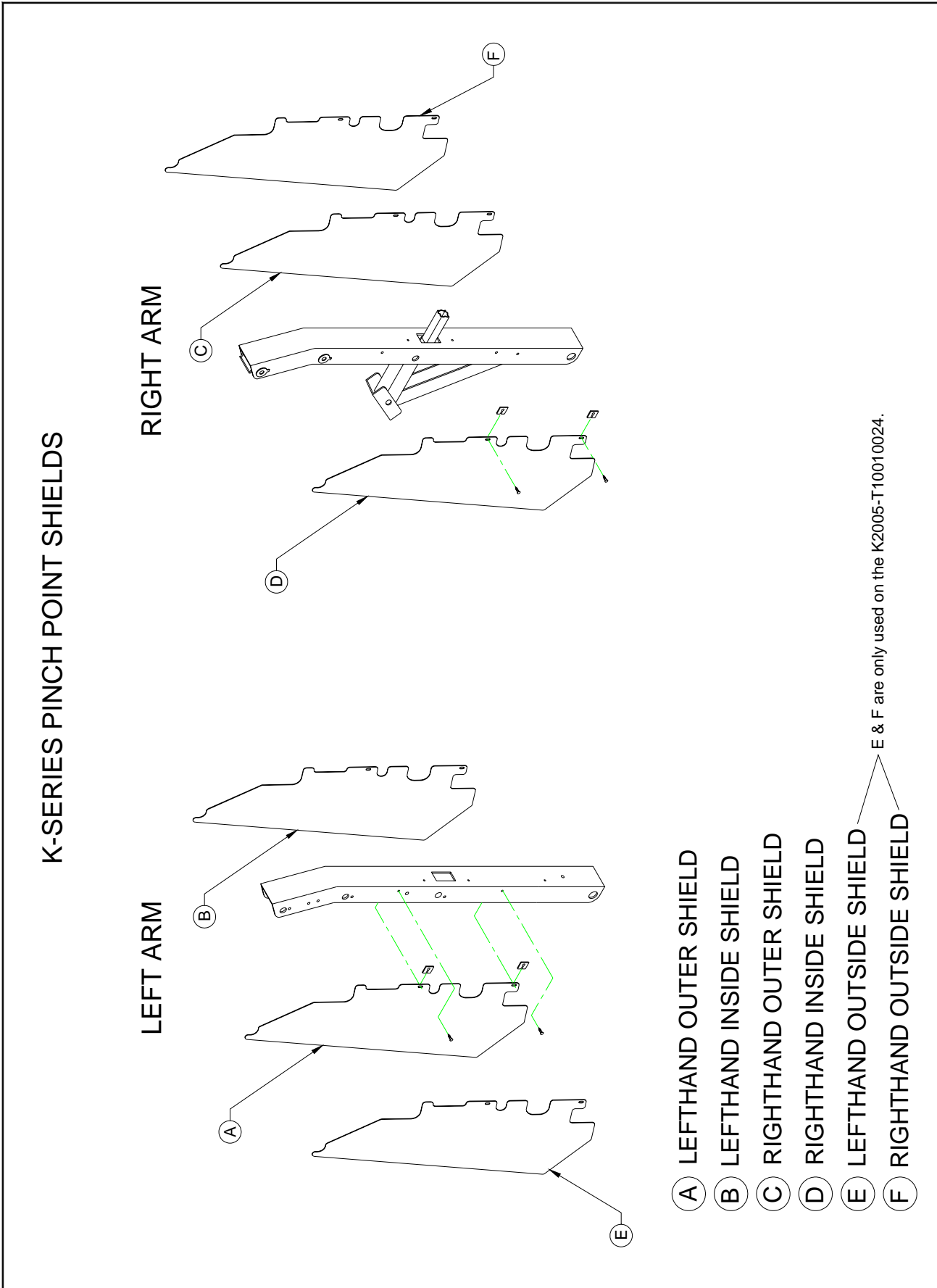

FIGURE 4-13: PINCH POINT SHIELDS

**FIGURE 4-13: PINCH POINT SHIELDS**

<b>MODEL</b>	<b>A</b> LEFT OUTER SHIELD	<b>B</b> LEFT INSIDE SHIELD	<b>C</b> RIGHT OUTER SHIELD	<b>D</b> RIGHT INSIDE SHIELD	<b>E</b> LEFT OUTSIDE SHIELD	<b>F</b> RIGHT OUTSIDE SHIELD
K1132	29167	29183	29183	29167	N/A	N/A
K1200 K1203 K1205	29162	29165	29178	29181	N/A	N/A
K2003 K2005 K2010	29162	29178	29178	29162	N/A	N/A
K2005- T10010024	29162	29178	29178	29162	29166	29182
K5005 K5010 K5511	29163	29179	29179	29163	N/A	N/A

HANDRAILS  
SERIAL NO's. 32000 – PRESENT

K-SERIES
DATE: 05/17/04

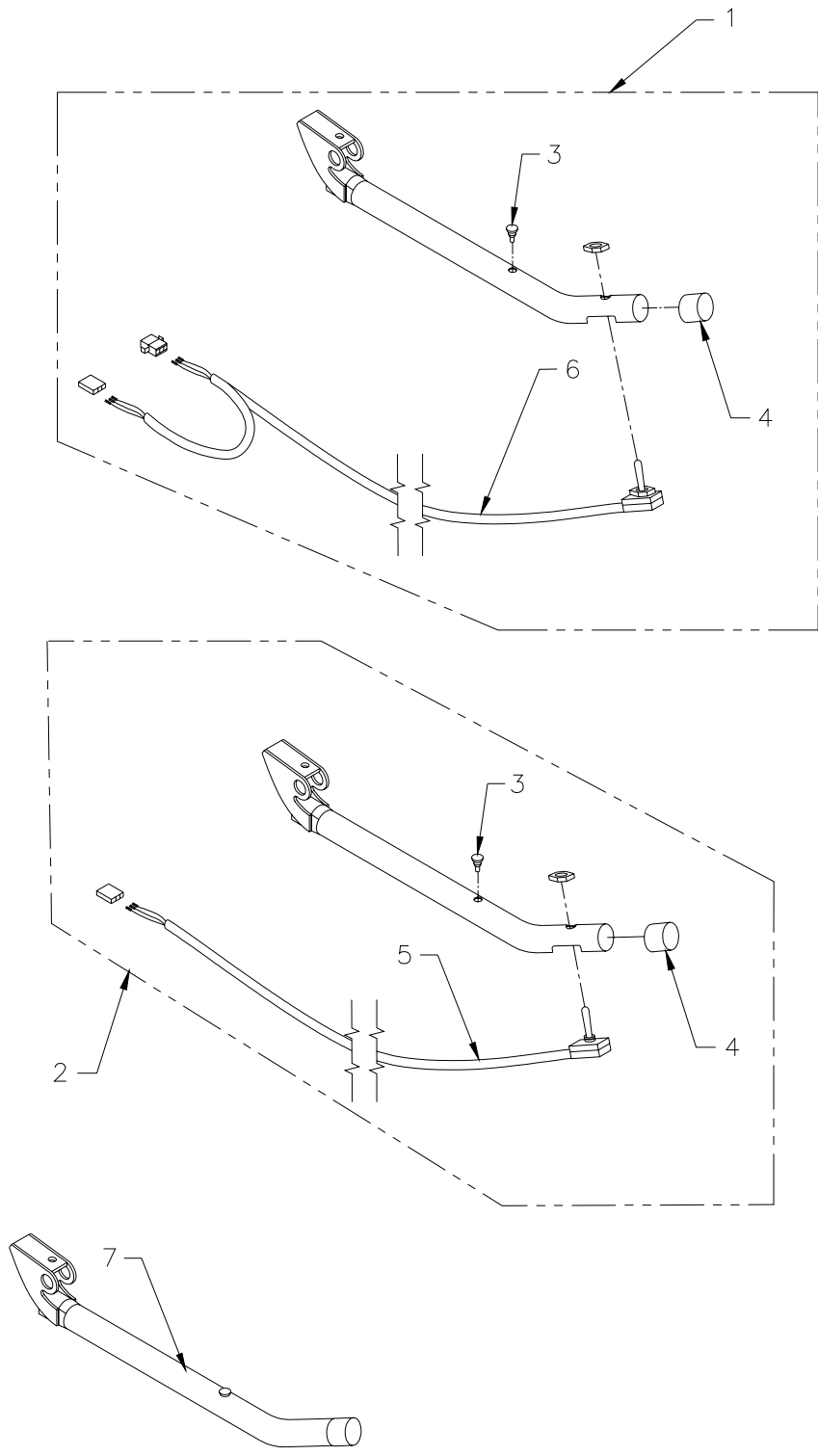

FIGURE 4-14: HANDRAIL ASSEMBLIES



FIGURE 4-14: HANDRAIL ASSEMBLIES

REF NO.	DESCRIPTION	QTY	PART
1	HANDRAIL ASSY, S1200, W/SWITCH, RH	1	VS-AC-161
1-1*	HANDRAIL ASSY, S2000, W/SWITCH, RH	1	VT-AC-281
2	HANDRAIL ASSY, S1200, W/SWITCH, LH	1	VS-AC-160
2-1*	HANDRAIL ASSY, S2000, W/O SWITCH, LH	1	VT-AC-282
2-2*	HANDRAIL ASSY, S2000, W/SWITCH, LH	1	VT-AC-284
3	BUMPER, RUBBER (BAG OF 10)	2	20653
4	CAP, ROUND BLACK	2	25550
5	HARNESS, HANDRAIL SWITCH	1	V2-ES-012
6	HARNESS, RIGHT HANDRAIL SWITCH	1	V2-ES-013
7	HANDRAIL ASSY, W/O SWITCH	1	VS-AC-159

\* Item not shown

K-SERIES ADA HANDRAIL  
SERIAL NO's. 32000 - PRESENT

K-SERIES
DATE: 05/25/04

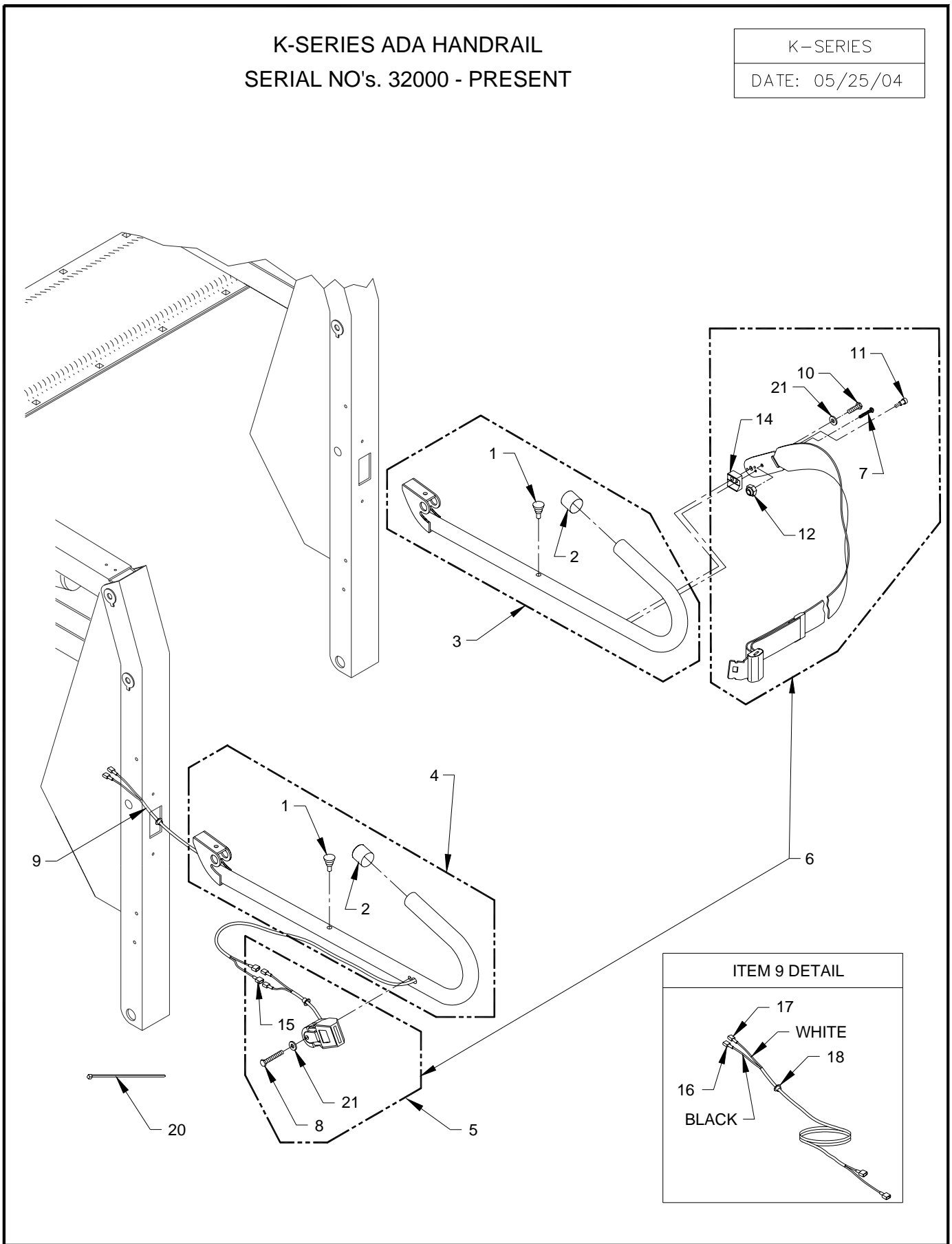

FIGURE 4-15: ADA HANDRAIL ASSEMBLIES

FIGURE 4-15: ADA HANDRAIL ASSEMBLIES

REF NO.	DESCRIPTION	QTY	PART
1	BUMPER, RUBBER	2	V2-AC-86
2	CAP, ROUND, BLACK	2	25550
3-1	HANDRAIL ASSY, ADA, LH, W/BUCKLE (P/N VT-AC-84 SUPERSEDED)	1	11714
3-2	HANDRAIL ASSY, ADA, S5000, LH (P/N V5-AC-84 SUPERSEDED)	1	11714
3-3	HANDRAIL ASSY, FMVSS, LH, W/BUCKLE	1	32479
4-1	HANDRAIL ASSY, ADA, S2000, RH (P/N VT-AC-85 SUPERSEDED)	1	11715
4-2	HANDRAIL ASSY, ADA, S5000, RH (P/N V5-AC-85 SUPERSEDED)	1	11715
4-4	HANDRAIL ASSY, FMVSS, RH, 34" W	1	32485
5	KIT, BUCKLE ASSY, W/SW & HARDWARE	1	12160
6-1	KIT, E-BELT INTERLOCK, 12VDC	1	13054
6-2	KIT, RESTRAINT BELT, 34", ADA	1	16092
7	SCREW, PAN HEAD, 10-24 x 1-3/4 (BAG OF 10)	1	15957
8	SCREW, HEX HEAD, 5/16-18 X 1.75, SST (BAG OF 10)	2	14440
9	KIT, ELECTRICAL HARNESS, RESTRAINT BELT	1	01274
10	SCREW, HEX HEAD, 5/16-18 X 3/4, SST (BAG OF 10)	1	17508
11	SCREW, 5/16-18 X 3/8, SST	1	28373
12	NUT, NYLON INSERT, 1/4-20, THIN, SST (BAG OF 10)	1	13339
14	SPACER, TRANSIT, HANDRAIL	1	V2-AC-063
15	TERMINAL, SLIP, MALE, 18-22, FULLINSUL (BAG OF 10)	2	13315
16	TERMINAL, SLIP, MALE, 14-16, FULLINSUL (BAG OF 10)	1	13317
17	TERMINAL, SLIP, MALE, 14-16, FULLINSUL (BAG OF 10)	1	13318
18	BUSHING, SNAP-IN	1	28-26-077
20	CABLE TIE, STD X 1.5 DIA, BLACK (BAG OF 10)	1	25697
21	WASHER, FLAT, .344X.688X.065 (BAG OF 10)	2	13350

APPENDIX 1

**K-SERIES (KLEARVUE) LIFT SPECIFICATIONS**

Power .....electro-hydraulic (power-up/gravity-down)	Rated load capacity..... 800 lbs
Pump rating: 12 volts DC.....65A avg/cycle, 1250 psi	Manual backup - raise ..... hand pump
24 volts DC.....32.5A avg/cycle, 1250 psi	Manual backup - lower ..... pressure release valve
Hydraulic cylinders .....2 ea, 1.5" dia	Lift weight..... 310-325 lbs

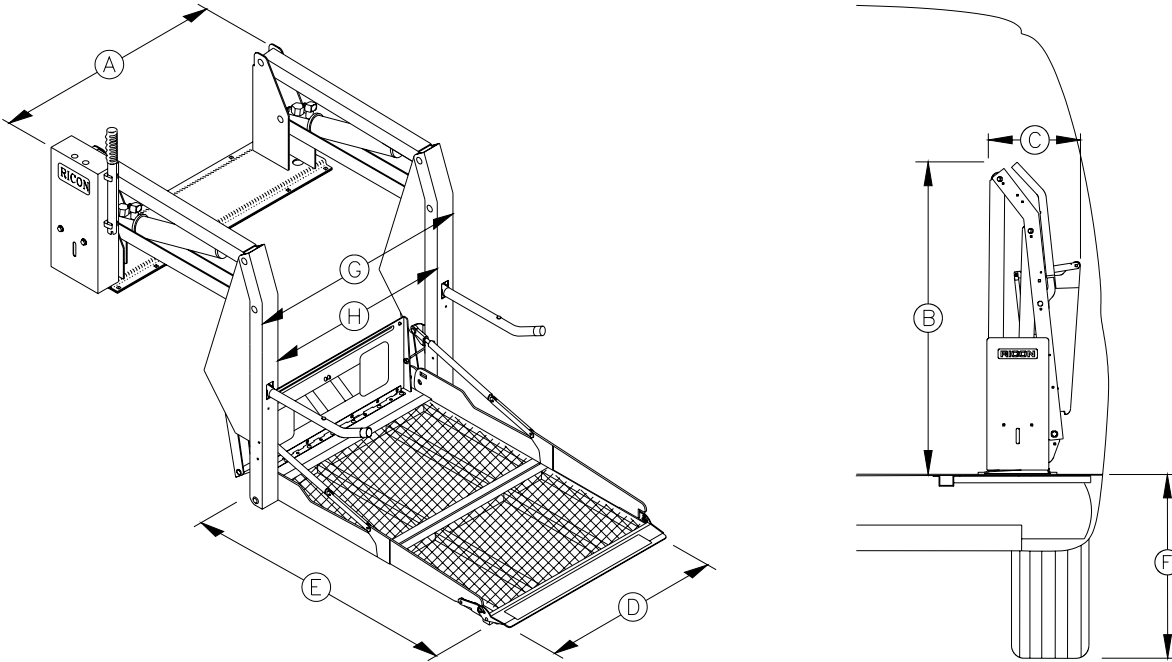

**DIMENSIONS – inches**

	A	B	C	D	E	F	G	H
Model	Stationary frame width	Height (folded)	Installation depth (folded)	Usable platform width	Usable platform length	Floor-to-ground travel	Traveling frame width	Clear entry width
K1101	47	38.6	15.5	30	38	24	37.5	29.25
K1132	43	38.6	15.5	26	38	24	33.5	25.25
K1200	47	43.5	15.5	30	44	28	37.5	29.25
K1203	47	43.5	15.5	30	51	28	37.5	29.25
K1205	49	43.5	15.5	32	51	28	39.5	31.25
K2003	47	47	15.5	30	51	37	37.5	29.25
K2005	49	47	15.5	32	51	37	39.5	31.25
K2005 ADA	49	55	15.5	32	51	37	39.5	31.25
K2010	50.5	47	15.5	34	54	37	41.5	33.25
K5005	49	60	15.5	32	51	43	39.5	31.25
K5010	50.5	60	15.5	34	54	43	41.5	33.25
K5503	45	60	15.5	30	51	48	37.5	29.25
K5505	49	60	15.5	32	51	48	39.5	31.25
K5510	50.5	60	15.5	34	54	48	41.5	33.25
K5511	50.5	60	15.5	34	51	48	41.5	33.25

NOTES:

This page intentionally left blank.