

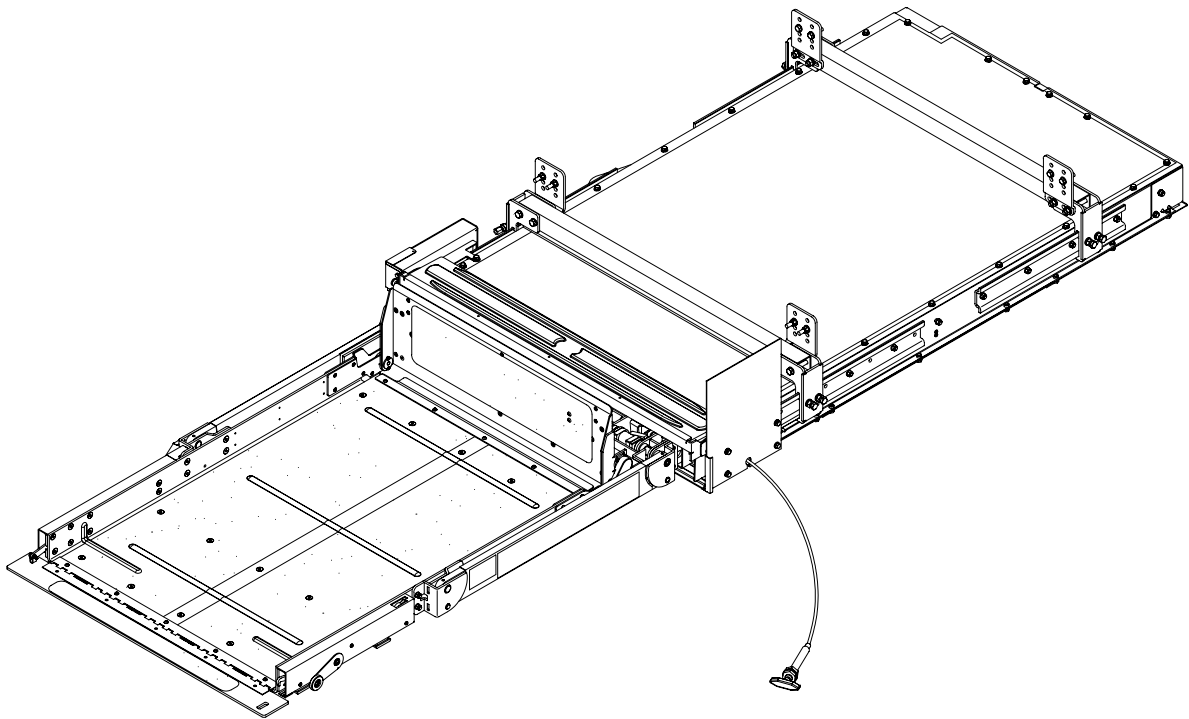

# MARK 1

## Under Vehicle Cassette Lift

Personal Wheelchair Lift  
DOT – Private Use Lift



**TABLE OF CONTENTS**  
**SERVICE MANUAL**

