

RICON[®]

Innovation in Mobility

RD02500 Series Power Sliding Door Operator

[PRINT ENTIRE MANUAL](#)

[TABLE OF CONTENTS](#)

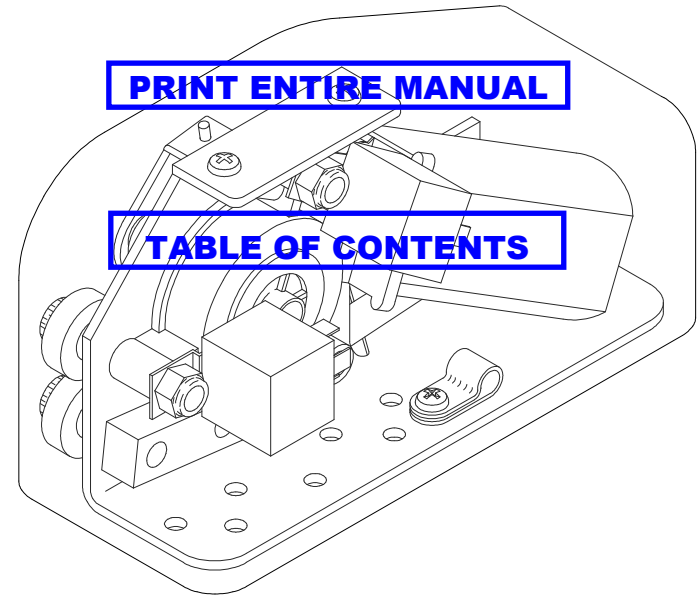

Operator Manual

02/14/02

32DD001.A

©1992-02 RICON CORPORATION

All Rights Reserved

RICON

U.S. Patent Nos 5,613,321; 5,794,381;
Other U.S. and foreign patents pending.
Printed in the United States of America

This RICON product must be installed and serviced by authorized RICON service technicians.

The operator must refer to this manual for operating instructions, and retain it for future reference.

Customer Name: _____
Installing Dealer: _____
Date Installed: _____
Serial Number: _____

REVISION RECORD

REV	PAGES	DESCRIPTION OF CHANGE	ECR/ECO
32DD003. A	All	New release, in two-book format.	3882/4864
END OF LIST			

TABLE OF CONTENTS

<i>Chapter:</i>	<i>Page</i>
I. INTRODUCTION	1-1
A. RICON ONE-YEAR LIMITED WARRANTY	1-1
B. SHIPMENT INFORMATION	1-3
C. GENERAL SAFETY PRECAUTIONS.....	1-3
D. PRODUCT TERMINOLOGY	1-4
II. OPERATING INSTRUCTIONS	2-1
A. SAFETY PRECAUTIONS	2-1
B. DAILY SAFETY CHECK	2-2
C. CONTROLS AND INDICATORS	2-2
D. LIFT OR RAMP CONTROL PENDANT	2-2
E. ELECTRICAL CONTROLS AND INDICATORS.....	2-3
F. POWER DOOR OPERATION.....	2-5
1. ENTER VEHICLE	2-5
2. EXIT VEHICLE	2-6
3. MANUAL OPERATION.....	2-6
III. MAINTENANCE	3-1
A. MAINTENANCE INFORMATION.....	3-1
B. MAINTENANCE SCHEDULE.....	3-1
C. TROUBLESHOOTING GUIDE	3-2

This page intentionally left blank.