

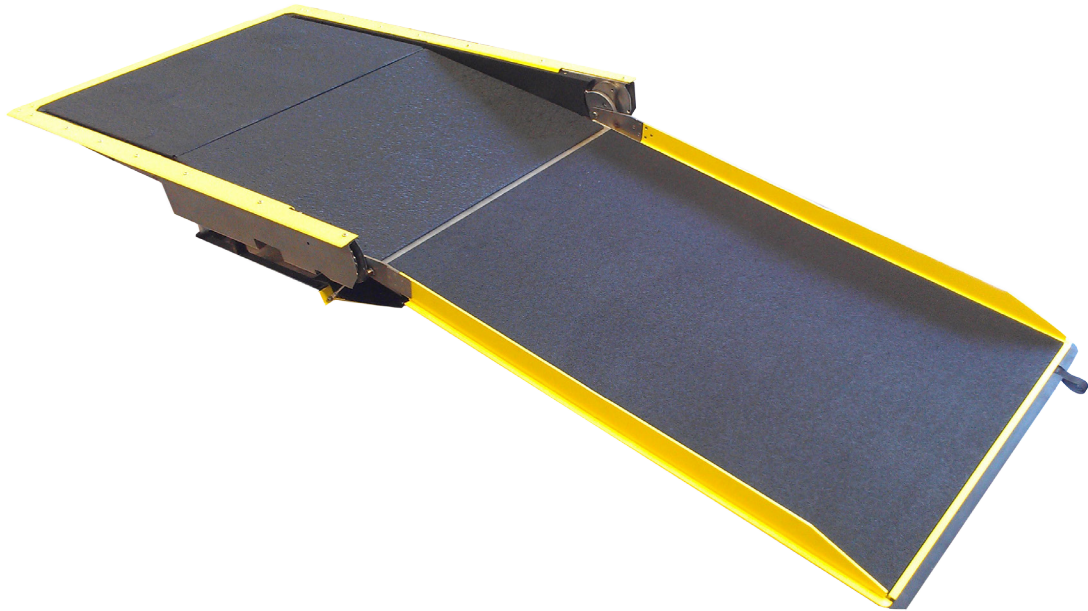

# **FoldOver<sup>®</sup>**

## **SSR-Series**

### **Single-Slope Low-Floor Bus Ramp**



## **Service Manual**

<https://ricondealer.wabtec.com>

**-Print-**

This Ricon service manual is only for use by Ricon dealers or qualified service technicians and is not intended for use by non-professionals. The manual provides essential instructions and reference information, which supports qualified technicians in the correct installation and maintenance of Ricon products.

Ricon dealers or qualified service technicians have the training and knowledge to perform maintenance work properly and safely. For the location of a Ricon dealer or qualified service technician in your area, call Ricon Product Support at 1-800-322-2884 or visit our website at [www.riconcorp.com](http://www.riconcorp.com).

Customer Name: _____
Installing Dealer: _____
Date Installed: _____
Serial Number: _____

**REVISION RECORD**

REV	PAGES	DESCRIPTION OF CHANGE	ECO
32DSSR02. A	ALL	NEW RELEASE.	

Chapter

Page

**I. FOLDOVER SSR-SERIES SINGLE-SLOPE RAMP INTRODUCTION..... 1-1**

**A. SINGLE-SLOPE RAMP FEATURES..... 1-1**

1. INTERLOCK SUPPORT ..... 1-1

2. AUDIBLE ALERT ..... 1-1

3. RAMP CONTROL PANEL ..... 1-1

**B. RICON PRODUCT SUPPORT..... 1-2**

**C. RICON TWO-YEAR LIMITED WARRANTY ..... 1-2**

**D. SHIPPING INFORMATION..... 1-4**

**E. CUSTOMER ORIENTATION..... 1-5**

**II. FOLDOVER SSR-SERIES SINGLE-SLOPE RAMP INSTALLATION..... 2-1**

**A. INSTALLATION GUIDELINES..... 2-1**

1. LOCATING MOUNTING BRACKETS ON BUS FRAME ..... 2-1

2. INSTALLING SINGLE-SLOPE RAMP IN FLOOR ..... 2-1

3. INSTALLING VEHICLE WIRING HARNESS..... 2-3

**B. FOLDOVER SINGLE-SLOPE RAMP COMPONENT REPLACEMENT AND ADJUSTMENTS.... 2-4**

1. CHAIN ASSEMBLY REPLACEMENT..... 2-4

2. GAS SPRING REPLACEMENT..... 2-6

3. CAM SHAFT REPLACEMENT ..... 2-7

4. COUPLER ADJUSTMENT..... 2-8

5. TIMING ADJUSTMENT ..... 2-9

6. SENSOR TARGET ADJUSTMENT FOR POSITION AND GAP..... 2-12

7. FINAL INSPECTION ..... 2-12

**III. FOLDOVER SSR-SERIES SINGLE-SLOPE RAMP MAINTENANCE..... 3-1**

**A. GENERAL SAFETY PRECAUTIONS..... 3-1**

**B. DAILY INSPECTION ..... 3-2**

**C. MAINTENANCE SCHEDULE ..... 3-2**

**D. RAMP COMPONENT INFORMATION ..... 3-3**

1. MOTOR DRIVE SYSTEM..... 3-3

2. SELF-ALIGNING ASSEMBLY ..... 3-3

3. ELECTRONIC CONTROLLER ..... 3-3

4. SENSOR LIGHT ACTIVITY DURING RAMP MOVEMENT..... 3-4

5. CIRCUIT BREAKERS AND FUSES ..... 3-4

6. ELECTRICAL DIAGRAMS..... 3-4

**E. WIRING DIAGRAM ..... 3-6**

**IV. FOLDOVER SSR-SERIES SINGLE-SLOPE RAMP PARTS DIAGRAMS AND LISTS..... 4-1**

**Appendix: Ramp Specifications..... 4-16**

This page intentionally left blank.

## I. FOLDOVER® SSR-SERIES SINGLE-SLOPE RAMP INTRODUCTION

This manual applies to the Ricon FoldOver® SSR-Series Single-Slope Low Floor Bus Ramp when installed in transit vehicles. The chapters in this service manual include a product description, maintenance instructions, and a spare parts list. The descriptions in this chapter apply to the Ricon FoldOver® SSR-Series Single-Slope Low Floor Bus Ramp when installed in transit vehicles. The FoldOver ramp is installed in transit vehicles to accommodate persons with disabilities using mobility-aid equipment or who cannot easily climb steps. The electro-mechanically powered ramp folds into the vehicle vestibule flooring when not in use.

All SSR-Series Single-Slope ramps have a 1000lb. (453kg) load limit. Passengers must use the ramp one at a time; **do not overload ramp**. Be certain that persons with mobility-aid equipment fit between the left- and right-side ramp barriers without any interference before allowing use of ramp.

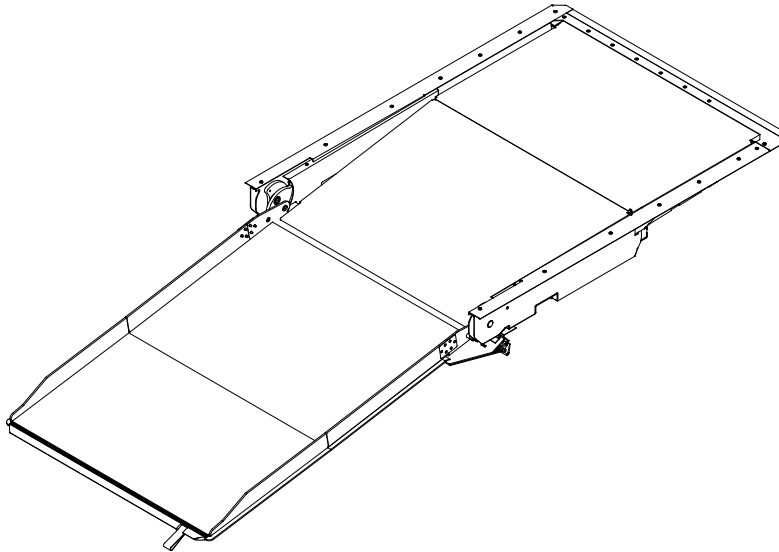

FIGURE 1-1: RICON FOLDOVER SINGLE-SLOPE RAMP

### A. SINGLE-SLOPE RAMP FEATURES

#### 1. INTERLOCK SUPPORT

The ramp electronics can interface with the vehicle interlock circuitry to prevent vehicle departure when ramp is deployed. The ramp interlock circuitry senses the position of the ramp (stowed or deployed) and makes this information available by the controller and through the 55-pin amp harness connector. A vehicle interlock circuit typically requires that the following conditions be met before operating power is supplied to ramp:

- Park vehicle and set parking brake.
- Place transmission in neutral.
- Open vehicle door adjacent to ramp.

#### 2. AUDIBLE ALERT

**NOTE:** This feature is optional and may not have been connected during ramp installation.

The ramp supports an audible alert device that sounds while the ramp is in motion.

#### 3. RAMP CONTROL PANEL

Refer to **Figure 1-2**. Ricon typically does not provide a control panel. However, the ramp can be operated with one similar to that shown (the actual panel appearance will vary between transit authorities and vehicles). The control panel is normally installed in the driver area. It should have a power ON/OFF switch, a power on indicator light, and a spring-loaded, three-position ramp control switch (center-off). The ramp receives power from the vehicle when the interlock conditions are met and the power on/off switch is ON. The control panel can then be used to transmit deploy or stow signals to the ramp.

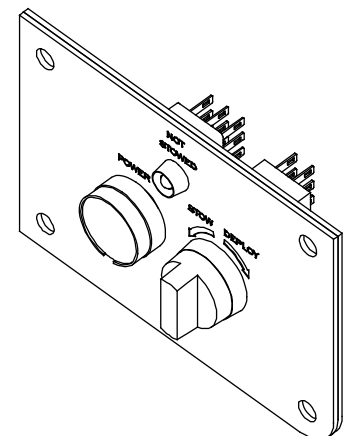

FIGURE 1-2: TYPICAL CONTROL PANEL

## B. RICON PRODUCT SUPPORT

If you have questions about this manual, or you need additional copies, please contact Ricon Product Support at the locations listed. Also, refer to the Ricon website at: [www.riconcorp.com](http://www.riconcorp.com)

### Ricon Corporation

1135 Aviation Place

San Fernando, CA 91340

Telephone: ..... (818) 267-3000

..... (800) 322-2884

(in US but outside 818 area code)

John Condon

Email: [jcondon@wabtec.com](mailto:jcondon@wabtec.com)

National Sales Manager

Telephone: ..... 209-603-5189

Mike O'Neill

Email: [moneill@wabtec.com](mailto:moneill@wabtec.com)

Eastern Area Sales Manager

Telephone: ..... 847-224-5087

Peter Buckley

Email: [pbuckley@wabtec.com](mailto:pbuckley@wabtec.com)

Central Area Sales Manager

Telephone: ..... 847-226-8102

Vapor Ricon Europe Ltd.

Meadow Lane

Loughborough, Leicestershire

LE 1HS, United Kingdom

Telephone: ..... (+044) 1509 635 920

## C. RICON TWO-YEAR LIMITED WARRANTY

The following warranty provides two years of limited coverage for the Ricon FoldOver SSR-Series Single-Slope Low Floor Bus Ramp.

## RICON-FAIVELEY FOLDOVER® SSR-SERIES SINGLE-SLOPE LOW FLOOR BUS RAMP TWO-YEAR LIMITED WARRANTY

**Ricon Corporation (Ricon)** warrants to the original purchaser of this product that Ricon will repair or replace, at its option, any parts that fail because of defective material or workmanship as follows:

- Repair or replace parts for a period of two years starting from the date ramp is put into service. Obtain a complete list of parts covered by this warranty from Ricon Product Support.
- Labor costs for specified parts replaced under this warranty for a period of two years from the date put into service. A Ricon rate schedule determines parts covered and labor allowed.

***This Warranty Does Not Cover:***

- Malfunction or damage of product parts caused by accident, misuse, lack of proper maintenance, neglect, improper adjustment, modification, alteration, mechanical condition of vehicle, road hazards, overloading, failure to follow operating instructions, or acts of nature (i.e., weather, lightning, flood).

**NOTE:** Ricon recommends this product be inspected by a Ricon dealer or qualified service technician at least once every six months, or sooner if necessary. Perform required maintenance at this time.

 <b>WARNING!</b>
<p>THIS PRODUCT HAS BEEN DESIGNED AND MANUFACTURED TO EXACT SPECIFICATIONS. ANY MODIFICATION OF THIS PRODUCT CAN BE HAZARDOUS.</p>

***This Warranty is Void If:***

- The product is not installed and maintained by a Ricon dealer or qualified service technician.
- The product is modified, in any respect from its original design, without written authorization from Ricon.

Ricon disclaims liability for any personal injury or property damage that results from operation or use of a Ricon product that is modified from the original Ricon design. No person or company is authorized to change the design of this Ricon product without written authorization from Ricon.

Ricon obligation under this warranty is exclusively limited to the repair or exchange of parts that fail within the applicable warranty period.

Ricon assumes no responsibility for expenses or damages, including incidental or consequential damages. Some states do not allow the exclusion or limitation of incidental or consequential damages, so the above limitation or exclusion may not apply.

*Important:* The warranty registration card must be completed and returned to Ricon within 20 days after product installation to validate this warranty. The warranty is not transferable.

The warranty gives specific legal rights. There may be other rights that vary in each state.



## D. SHIPPING INFORMATION

When the product is received, unpack the product and check for freight damage. Claims for any damage should be made to the carrier immediately.

Be sure the ramp assembly contains all items listed on the included bill of material. Please report any missing items immediately to Ricon Product Support. Save bill of material for later reference. Return the completed warranty and owner registration cards to Ricon within 20 days to validate warranty.

**NOTE:** The Sales or Service personnel must review the Warranty and this Operator Manual with the user to be certain that they understand how to safely operate the product. Instruct the user to follow the operating instructions without exception.

### E. CUSTOMER ORIENTATION

1. **Figure 1-3** shows major components of the SSR-Series FoldOver® Single-Slope ramp. A description of each component is provided in **Table 1-1**. Refer to Chapter IV “Parts Diagrams and Lists” for more details.

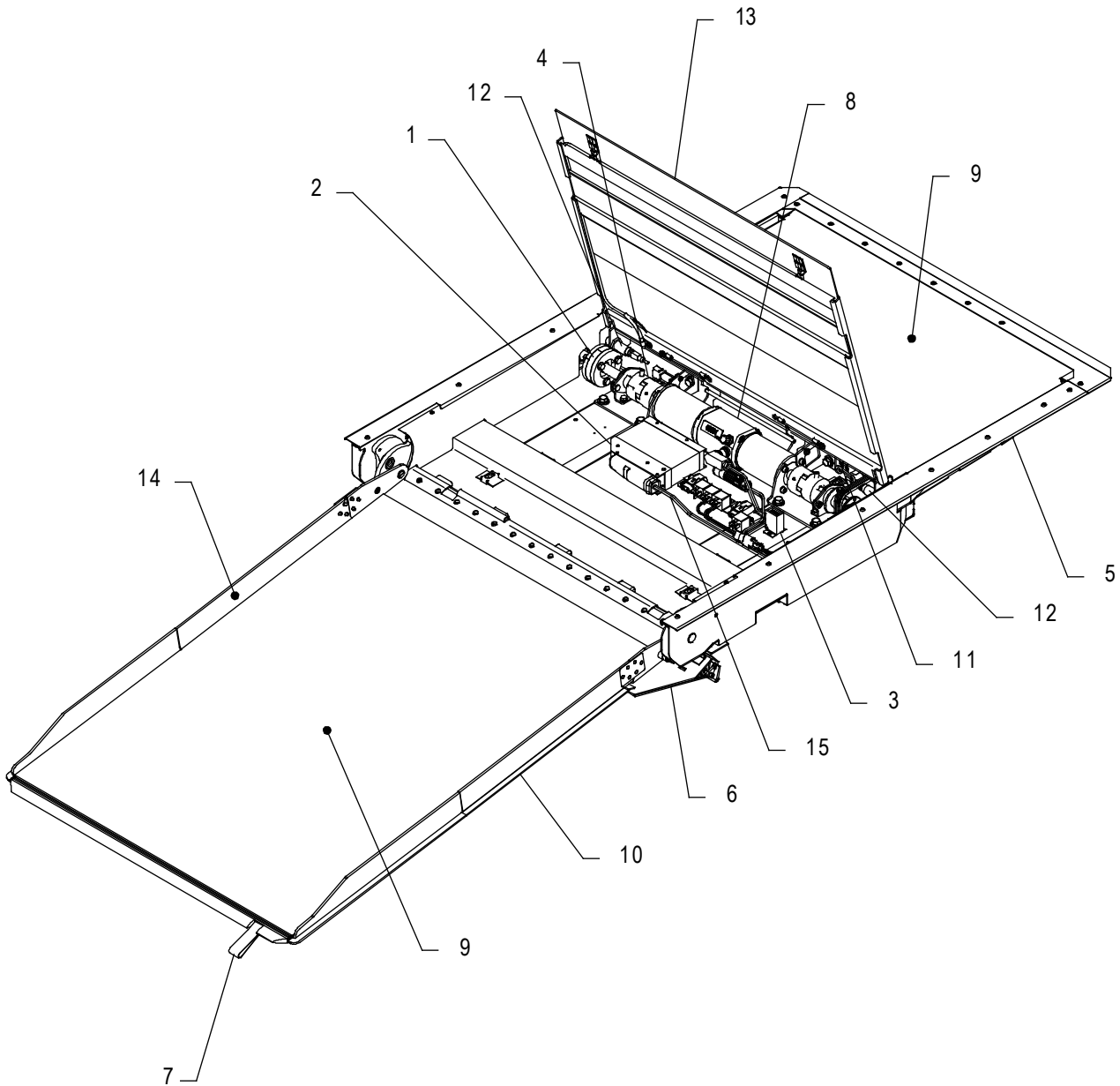

RSM0061001

**FIGURE 1-3: SSR-SERIES MAJOR RAMP COMPONENTS**

**TABLE 1-1: MAJOR SSR-SERIES FOLDOVER® SINGLE-SLOPE RAMP COMPONENTS**

ITEM	DESCRIPTION
Front, Rear, Left and Right	Reference point from outside the vehicle looking inward.
1	Adjustable Coupler - Use for adjustment and alignment of chain sprocket.
2	Controller - Translates electrical commands from bus control panel into signals that control ramp electro-mechanical components. Monitors ramp position and drives counter.
3	Counter - Counts each cycle.
4	Couplings - (Left & Right) Transmits rotary motion and attaches the drive motor shaft assemblies to the dual gearboxes.
5	Flange Kit - Perimeter trim pieces that are installed after the ramp has been installed in vehicle.
6	Front Cover - Front edge of ramp that opens and closes when platform is deployed or stowed.
7	Lifting Strap - Use to assist in manual deploy or stow ramp.
8	Motor Drive System - Electro-mechanical motor-gearbox combination used to operate the ramp.
9	Non-Slip Surface - Flooring over which passengers traverse.
10	Platform Assembly - Area where passengers traverse over to enter and exit vehicle.
11	Positive Connection Block - Connection through which the ramp receives power from vehicle.
12	Proximity Sensors - Magnetic sensor devices that send signals to the ramp controller to indicate when the ramp is fully stowed (locks electromagnets) or deployed (unlocks electromagnets).
13	Slanted Floor Plate (Access Cover) - Portion of ramp that passenger traverses over to enter and exit vehicle which also provides access to electro-mechanical ramp components.
14	Ramp Tray Barrier - Left and Right side barrier of platform.
15	Harness - Integrates conduits, relays, etc.
<b>END OF TABLE</b>	

## II. FOLDOVER® SSR-SERIES SINGLE-SLOPE RAMP INSTALLATION

### A. INSTALLATION GUIDELINES

Careful installation of the Ricon FoldOver® Single-Slope ramp contributes to proper and safe operation. Use the electrical wiring diagram in **Chapter III, Figure 3-4** to supplement this section.

#### 1. LOCATING MOUNTING BRACKETS ON BUS FRAME

Use a rigid fixture that substitutes for the ramp assembly when positioning ramp mounting brackets on the bus frame. If the ramp assembly is used to position the mounting brackets, verify that it is correctly located relative to the vehicle floor, etc. Accurate positioning of the brackets prevents twisting or warping of ramp frame when installing and tightening the mounting hardware. A warped frame may cause the ramp motion to be erratic. Set the height of the ramp flooring surface flush to the surrounding floor structure to prevent a tripping hazard.

#### 2. INSTALLING SINGLE-SLOPE RAMP IN FLOOR

The location of the ramp depends on its path of motion. The ramp must be positioned so it can move unobstructed through its required range of travel.

- a. Trim away floor material to allow ramp assembly to drop into floor opening.

**NOTE:** Do Not install ramp trim (flange kit) until ramp is installed in bus. The ramp trim overlaps the perimeter gap between the sides of the enclosure and the bus structure. The typical gap between the sides of the enclosure and the bus structure is 1/8 inch. Use shims to fill gap.

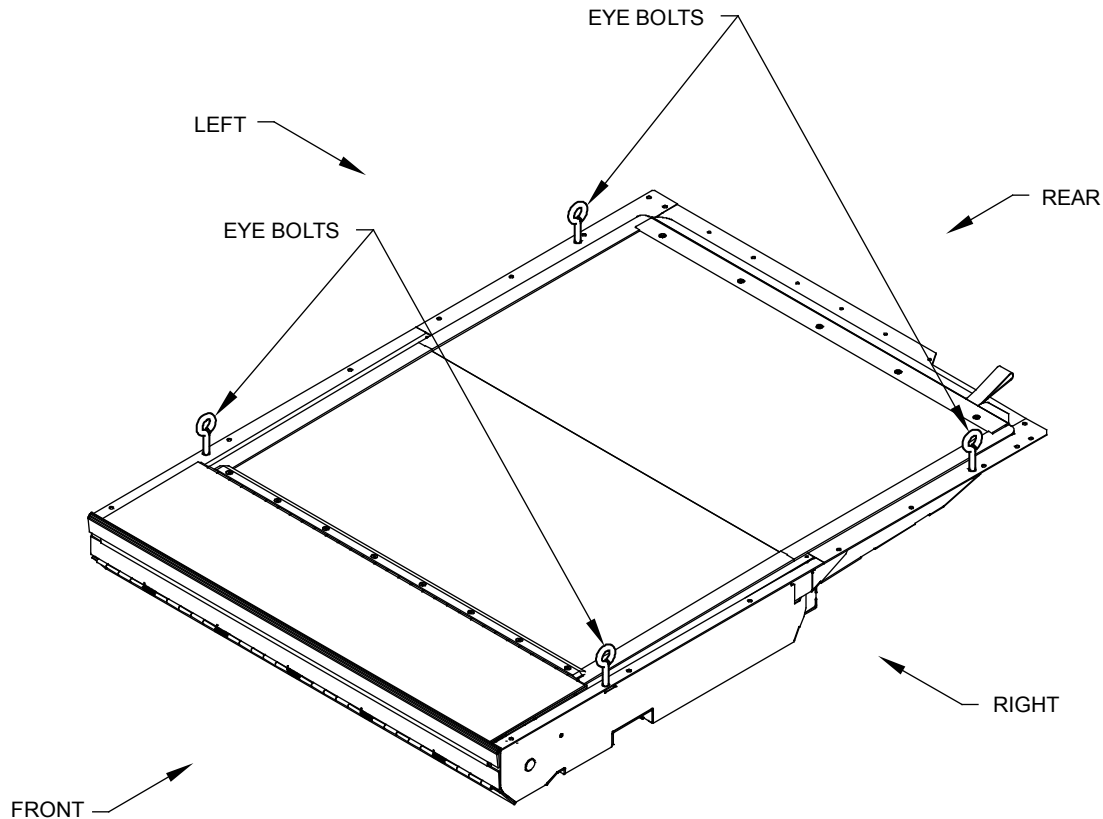

RSM0060700

FIGURE 2-1: RAMP LIFTING EYE BOLTS

 **WARNING!**

TAKE EXTREME CARE WHEN POSITIONING RAMP INTO BUS. BE SURE TO FOLLOW PROPER OPERATION AND SAFETY INSTRUCTIONS WHEN USING LIFTING DEVICE.

- b. Refer to **Figure 2-1**. Attach lifting device hooks to pre-installed eye bolts.
- c. Use lifting device to place ramp into bus.
- d. Lower ramp onto bus floor. Ensure that rear ramp flange rests on bus floor.

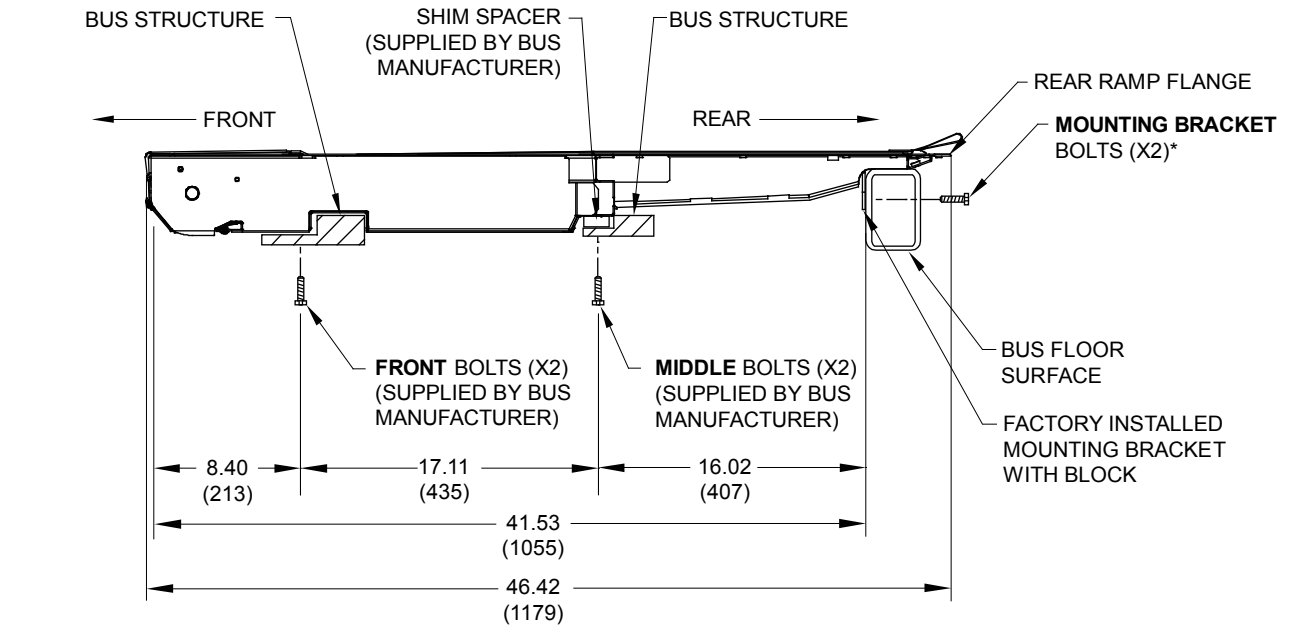

**RIGHT SIDE VIEW**

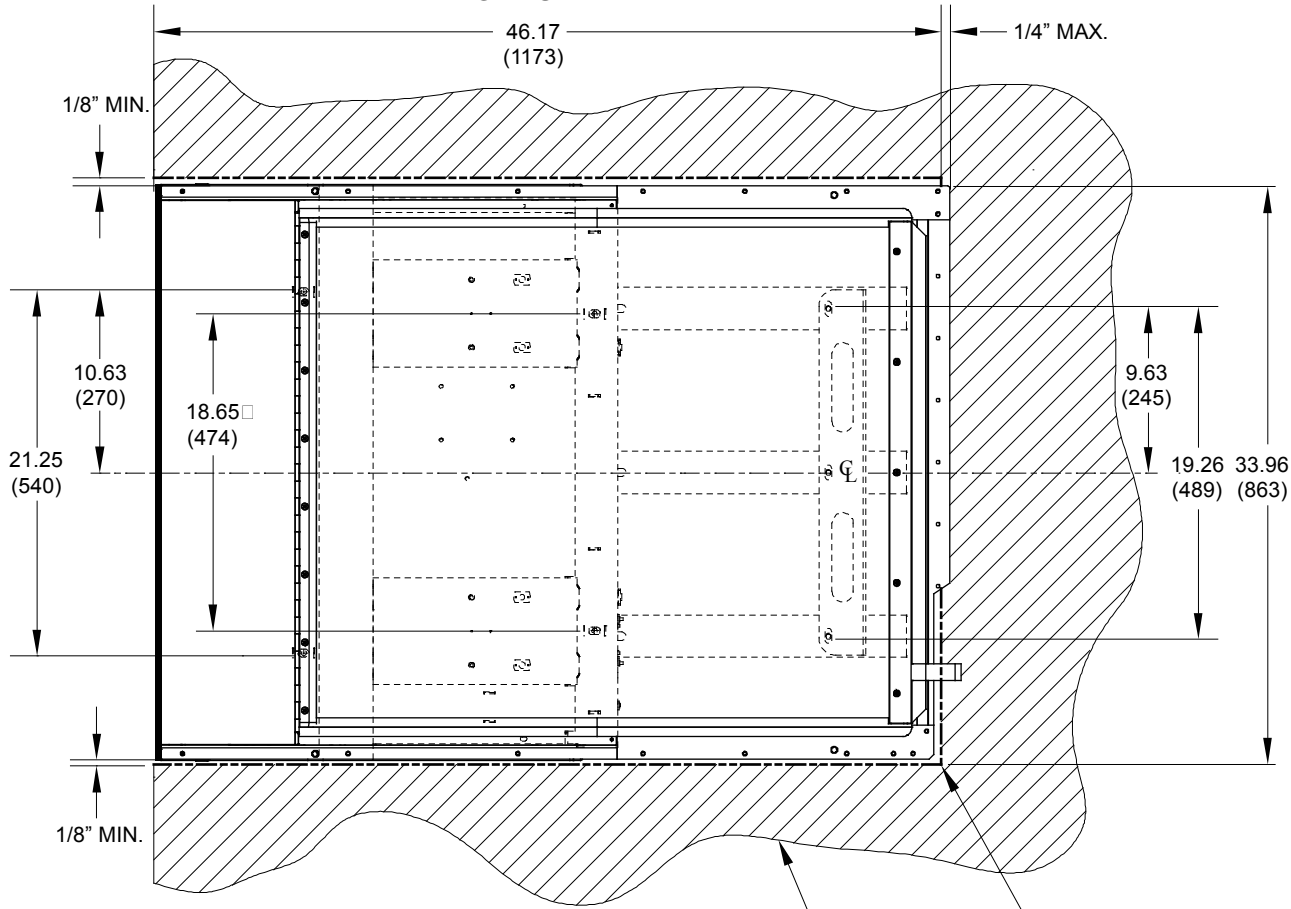

**TOP VIEW  
(SHOWN WITHOUT LH & RH TRIM)**

- NOTES:
- DIMENSIONS IN INCHES  
MILLIMETERS IN PARENTHESES.
  - \* REFERENCE MOUNTING BRACKET KIT  
(P/N 43936 OR 56383) PER SPECIFIED APPLICATION.

RSM0060801

**FIGURE 2-2: RAMP INSTALLATION (SHORT RAMP SHOWN)**

**NOTE:** Refer to **Figure 2-2**. Ramp should sit securely and level on bus structure. If ramp does not sit level on bus structure, install appropriate shim spacers accordingly.

<p><b>⚠ CAUTION!</b></p>
<p>FOLLOW SEQUENCE FOR SECURING RAMP ONTO BUS STRUCTURE. DEVIATION FROM THE INSTALLATION SEQUENCE CAN CAUSE RAMP WARPAGE.</p>

- e. Refer to **Figure 2-2**. Install and tighten two (2) **front** bolts.
- f. Refer to **Figure 2-2**. Install and tighten three (3) **rear mounting bracket** bolts.

**NOTE:** Mounting bracket kit is pre-installed at the factory and is configured according to bus manufacturer. Refer to mounting bracket kit (i.e. Kit P/N 43936, Kit P/N 56383) part number for vehicle installation.

- g. Inspect middle hardware installation. If space is present between the ramp frame and bus structure, install appropriate shim spacer then install and tighten two (2) **middle** bolts.
- h. Refer to **Figure 2-3**. Install left and right trim pieces with attaching hardware provided.

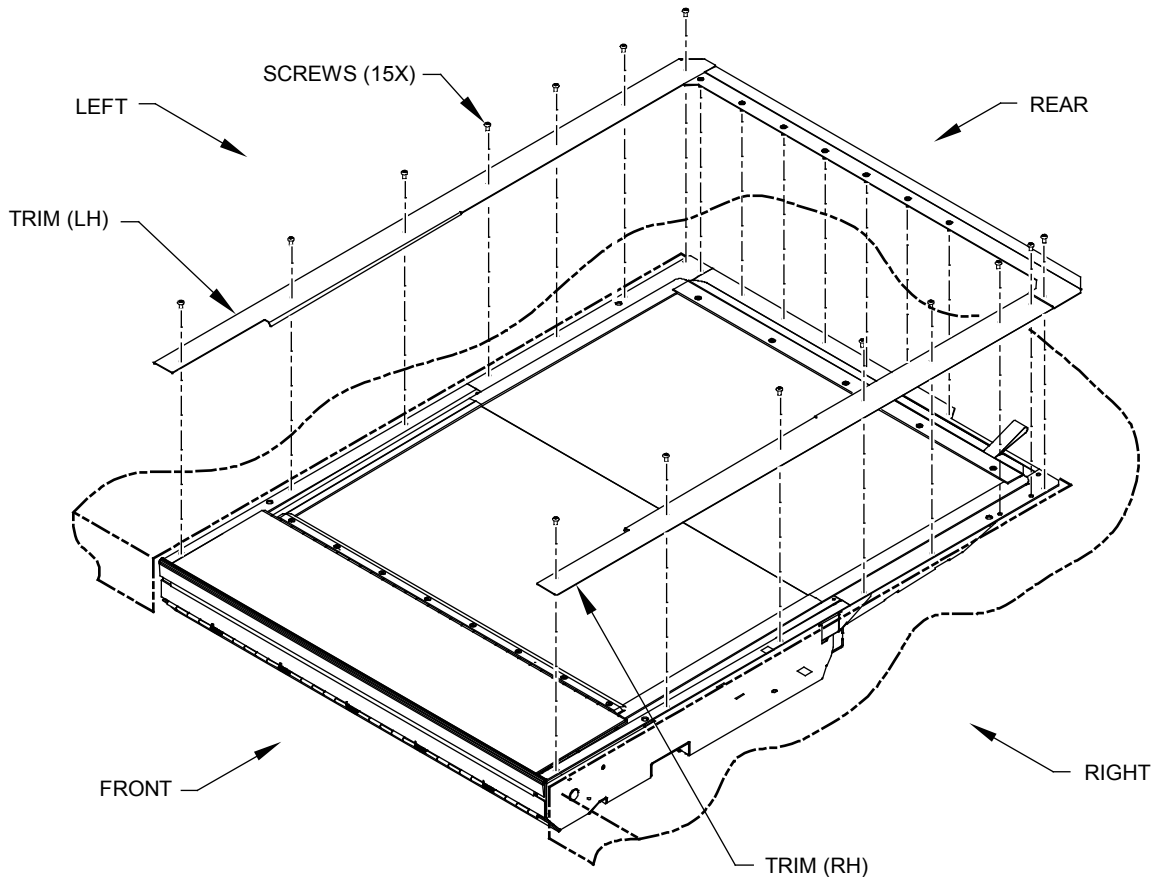

RSM0060900

**FIGURE 2-3: RAMP TRIM INSTALLATION**

**3. INSTALLING VEHICLE WIRING HARNESS**

Route wiring harness from vehicle ramp controls to rear of ramp. Use the supplied electrical installation kit to connect vehicle control wiring to the ramp interface connector (Ricon P/N 47100). See **Table 2-1** for 12-pin Deutsch connector pin and signal descriptions.

- a. Disconnect vehicle battery.

<p><b>⚠ CAUTION</b></p>
<p>Be sure that harness does not interfere with any moving parts, or binds against any parts, or is pinched in any way.</p>

- b. Install Main Circuit Breaker Kit (P/N 36267). Avoid installing near a heat source.
- c. Refer to **Chapter III Electrical Diagram, Figure 3-4**. Route and install black ground cable (P/N 43929) to ground connection and red power cable (P/N 43928) to positive connection block.

- d. Route and install ramp interface harness (supplied by bus manufacturer) to ramp interface connection.

Table 2-1: 12-PIN DEUTSCH CONNECTOR SIGNAL DESCRIPTION	
Pin	Description
1	STOW Signal
2	STOW Input
3	Ground
4	NOT STOWED Signal
5	DEPLOY Input
6	Battery Power
7	Ramp Enable
8	Counter Input

- e. Cycle ramp a few times to ensure ramp is working properly.

## B. FOLDOVER SINGLE-SLOPE RAMP COMPONENT REPLACEMENT AND ADJUSTMENTS

Removal of ramp assembly from vehicle and onto a workbench or work stand is necessary for access to enclosure components. Moving the ramp assembly to a workbench or work stand may require two people.

Follow all safety requirements before proceeding with any of the following procedures.

### 1. CHAIN ASSEMBLY REPLACEMENT

In the event that the chain assembly may require replacement, follow the removal and installation procedures. The chain assembly is located on the outside of the enclosure therefore the ramp tray will not require removal to access the chain assembly.

**NOTE:** Unequal tension on the chain assembly may cause different torques on ramp tray sprockets and will possibly cause ramp tray asymmetry error. Removal of ramp components will require adjustment of timing.

- Deploy wheelchair ramp to ground level.
- Remove Floor Cover to access enclosure components.
- Remove and retain seven (7) screws (#10-32) then remove and retain Flange Trim.
- Refer to **Figure 2-4**. Remove and retain screw (6-32 x 1/4) then remove RH Inner Chain Cover.
- Refer to **Figure 2-4**. Remove and retain two (2) screws (10-24 x 1/4) and one (1) button head screw (10-24 x 7/8) then remove Drive Train Cover.



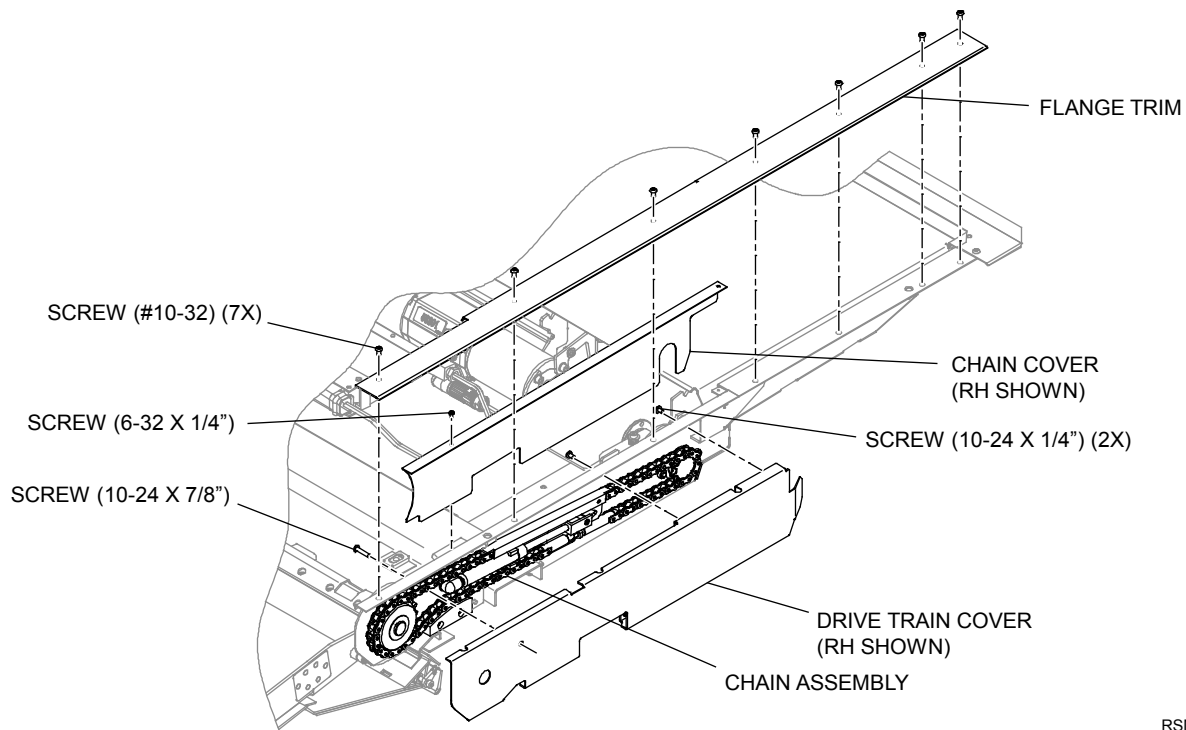

RSM0074600

**FIGURE 2-4: CHAIN COVER AND DRIVE TRAIN COVER**

**NOTE:** Chain Assembly and Large Sprocket alignment markings. Check for pre-marked alignment marks located on large sprocket and on chain link. If either of the pre-marks is not visible or present, use a marker to create alignment marks as shown in **Figure 2-5**. Sprocket and chain marked in this position simulates fully stowed position.

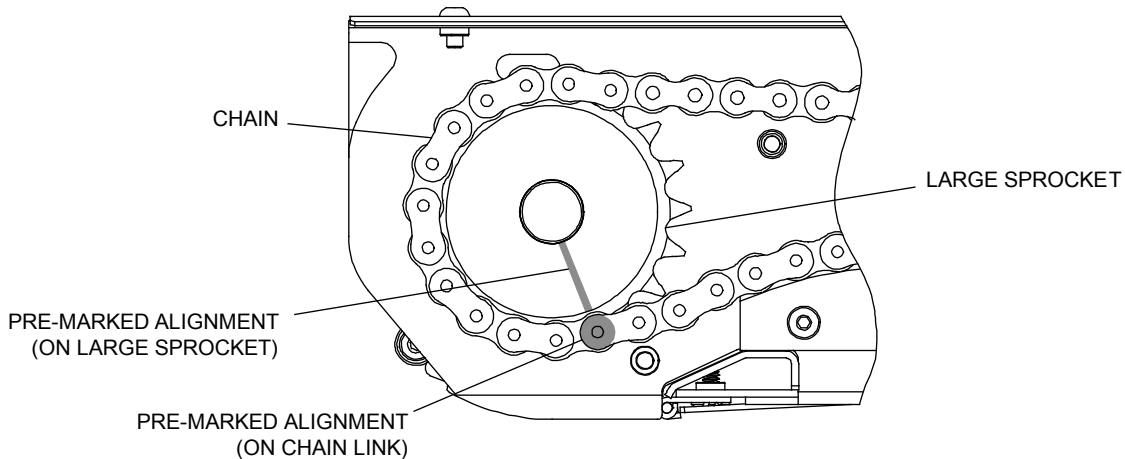

RSM0065200

**FIGURE 2-5: CHAIN ASSEMBLY**

- f. Refer to **Figure 2-6**. Detach Cable and Spring to loosen tension on gas spring.
- g. Refer to **Figure 2-6**. Loosen jam nut from chain tension shaft then unscrew threaded shaft from chain tension shaft.
- h. Refer to **Figure 2-6**. Unhook gas spring from chain hook.
- i. Refer to **Figure 2-6**. Detach and remove chain assembly from enclosure.

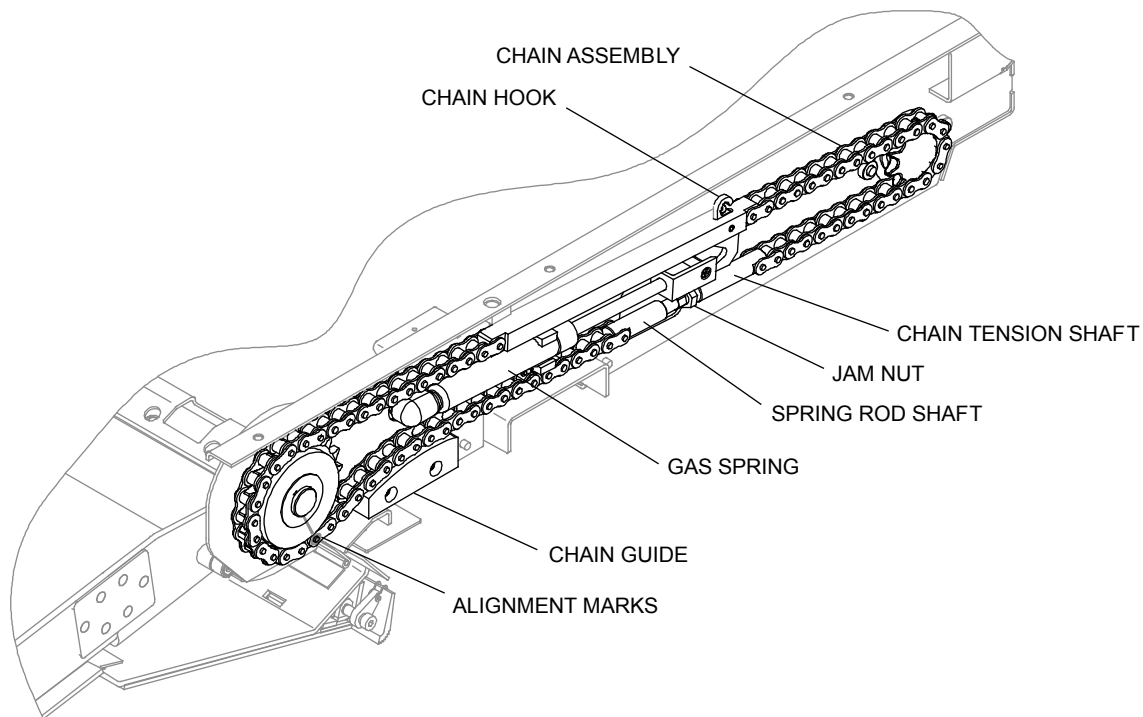

RSM0074500

**FIGURE 2-6: CHAIN ASSEMBLY**

**NOTE:** Unequal tension on the chain assembly may cause different torques on ramp tray sprockets and will possibly cause ramp tray asymmetry error. Ensure equal stiffness on left and right hand chain assembly after installation.

**NOTE:** Refer to **Figure 2-6**. For preventative maintenance replace chain guides if signs of wear are visible.

j. Refer to **Figure 2-6**. Replace and install left hand or right hand chain guides as necessary when chain assembly has been removed.

k. Refer to **Figure 2-6**. Install pre-assembled chain assembly onto large sprocket.

**NOTE:** Align pre-marked alignment marking on large sprocket with alignment marking on chain link. Factory built models receive pre-marked alignments. Kits may require marking if received without any alignment marks.

l. Route chain assembly onto small sprocket then install threaded stud into Chain Tension Shaft.

m. Turn threaded stud Clockwise (CW) until there is tension on chain link. Tighten jam nut against Chain Tension Shaft.

n. Attach Gas Spring and Chain Assembly Hook.

o. Refer to **Figure 2-4**. Attach RH Inner Chain Cover then install screw (6-32 x 1/4).

p. Refer to **Figure 2-4**. Attach Drive Train Cover onto enclosure then install two (2) screws (10-24 x 1/4) and one (1) button head screw (10-24 x 7/8).

q. Refer to **Figure 2-4**. Attach Flange Trim then install seven (7) screws (#10-32).

r. Test the chain assembly by deploying and stowing ramp 2-3 cycles.

## 2. GAS SPRING REPLACEMENT

The Gas Spring reduces the speed for which the ramp tray will travel when moving in the stowed or deployed position. To replace the Gas Spring follow the procedure below.

a. Apply power to wheelchair ramp.

b. Deploy ramp onto a workbench or onto fixture that will support the weight of the ramp tray.

c. Remove power from ramp or vehicle.

d. Follow the procedure Section B.1 (Chain Assembly Replacement) to remove the Chain Cover and Drivetrain Cover.

- e. Refer to **Figure 2-7**. Detach Gas Spring from Spring Guide and ball stud.

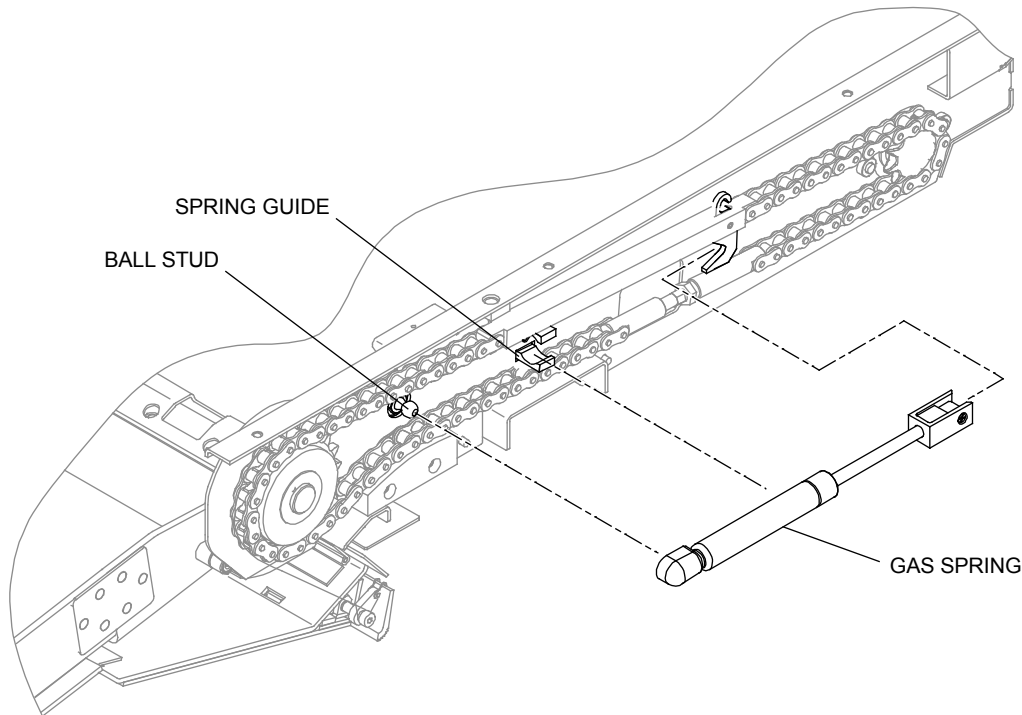

RSM0074700

**FIGURE 2-7: GAS SPRING**

- f. Refer to **Figure 2-7**. Install new Gas Spring. Route the end of Gas Spring onto Spring Hook then attach into Spring Guide and secure onto ball stud.
- g. Re-install Chain Assembly covers as covered in Section B.1 (Chain Assembly Replacement).
- h. Repeat step a through step g as necessary for opposite side.
- i. Once power has been restored to ramp, cycle the ramp 2-3 cycles to ensure gas spring is working properly.

### 3. CAM SHAFT REPLACEMENT

The CAM shaft adjusts the slope of the ramp to provide the least possible, continuous slope. In the event that the CAM shafts require replacement, follow the procedure below.

- a. Apply power to wheelchair ramp.
- b. Deploy ramp onto a workbench or onto fixture that will support the weight of the ramp tray. Ramp tray will be removed to access CAM shaft.
- c. Remove power from ramp or vehicle.
- d. Detach two (2) Front Cable from Front Cover Assembly.
- e. Refer to **Figure 2-8**. Remove and retain eight (8) screws from Front Cover Assembly.

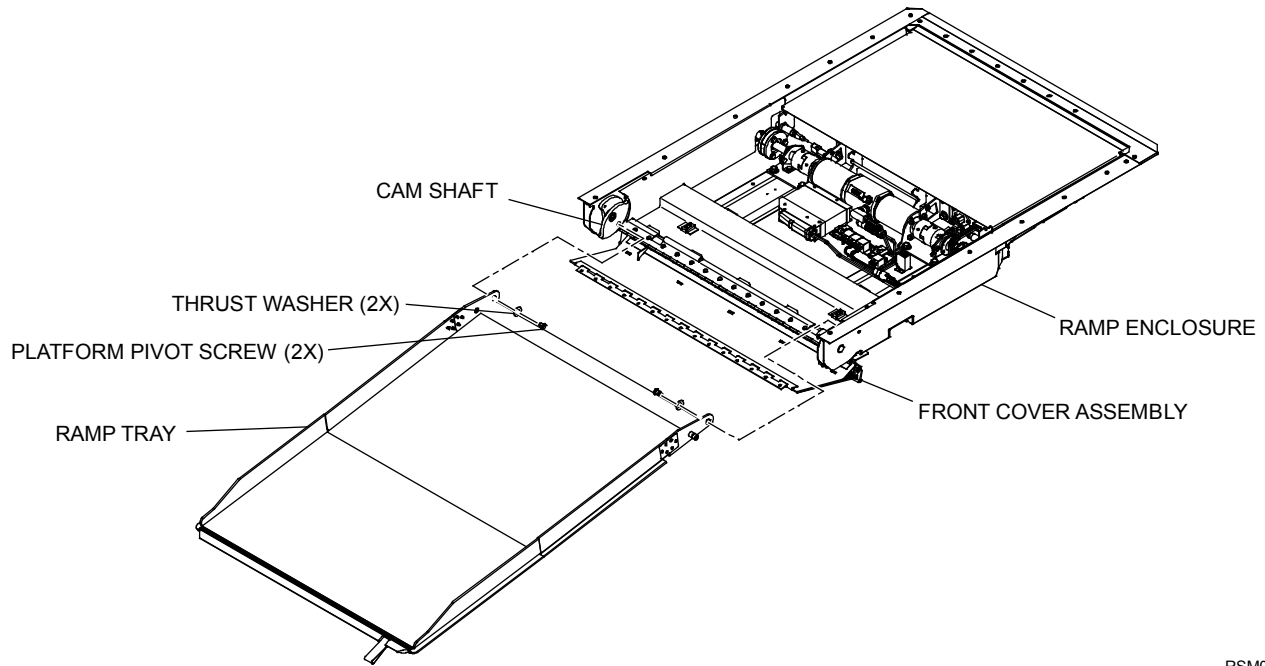

RSM0065500

**FIGURE 2-8: RAMP TRAY REMOVAL**

- f. Refer to **Figure 2-8**. Remove and retain two (2) platform pivot screws and two (2) thrust washers.
- g. Refer to **Figure 2-8**. Carefully detach ramp platform from ramp enclosure.
- h. Refer to Section B.1 (Chain Removal) to remove Chain Covers and Chain Assembly.
- i. Refer to **Figure 2-9**. Remove and retain large Sprocket #40.

**NOTE:** For preventative maintenance, check large Sprocket #40 if signs of wear are visible. Refer to **Chapter IV** for replaceable spare parts.

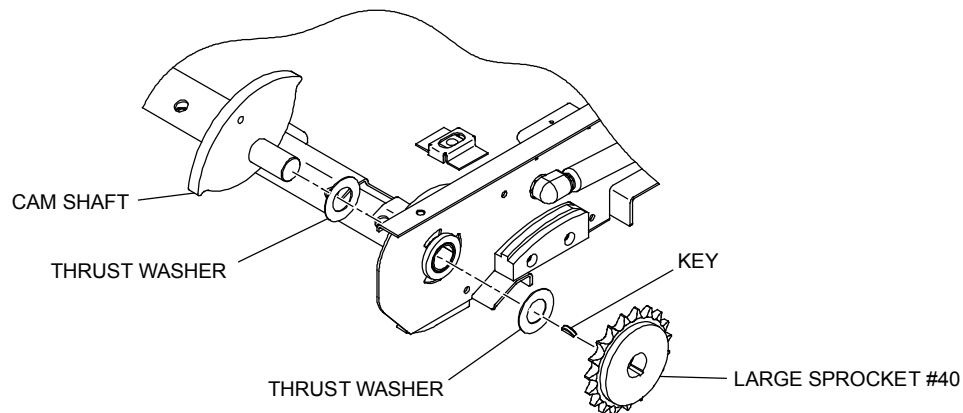

RSM0065600

**FIGURE 2-9: CAM SHAFT REMOVAL**

- j. Refer to **Figure 2-9**. Remove and retain Key from CAM Shaft then remove and retain thrust washer.
- k. Refer to **Figure 2-9**. Detach CAM Shaft from enclosure and replace.
- l. Insert thrust washer over shaft of CAM then insert into enclosure.
- m. Align CAM Shaft hole with Front Cover Plate hole that is attached to enclosure.
- n. Refer to **Figure 2-10**. Insert a tool into the hole of CAM Shaft and Front Cover Plate hole.

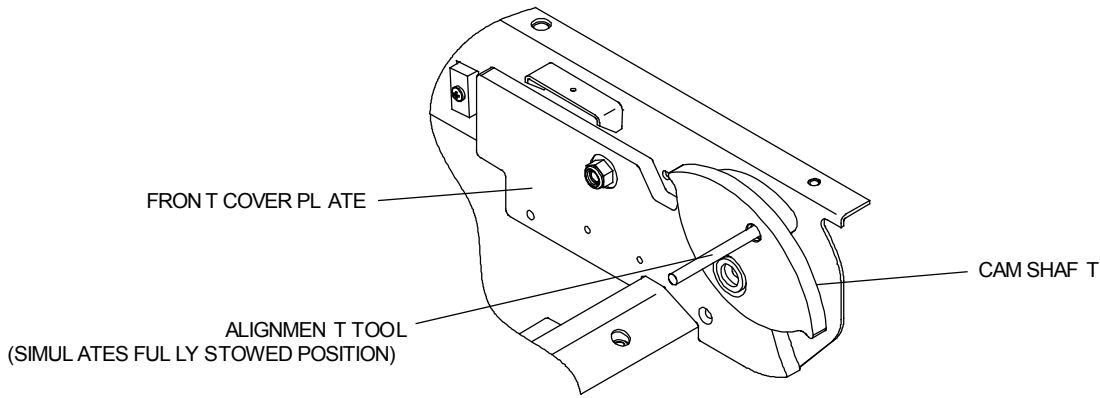

RSM0065700

**FIGURE 2-10: CAM SHAFT ALIGNMENT**

**NOTE:** Tool inserted into hole of CAM Shaft and Front Cover Plate is done to keep CAM Shaft aligned in the fully stowed position while installation of large sprocket and chain assembly is performed.

- o. Insert thrust washer on outer end of CAM Shaft then insert Key into slot of CAM Shaft.
- p. Use pliers to clamp down on Key and onto CAM Shaft slot to lock Key in place.
- q. Insert large Sprocket #40 while lining up Key with slot of sprocket.
- r. Follow procedure to install Chain Assembly in Section B.2 (Chain Replacement).
- s. Follow procedure for ramp deployment timing.

**4. COUPLER ADJUSTMENT**

As noted in the Chain Assembly Installation, unequal tension on the springs may cause different torques on ramp tray sprockets and will possibly cause ramp tray asymmetry error. The adjustable coupler will allow for adjustment and alignment of the chain assembly.

- a. Refer to **Figure 2-11**. Loosen three bolts and nuts of the adjustable coupler.

**NOTE:** Do not completely remove bolts and hex nuts. Only loosen enough to be able to adjust coupler. Nuts will need to be torque adjusted before completing procedure.

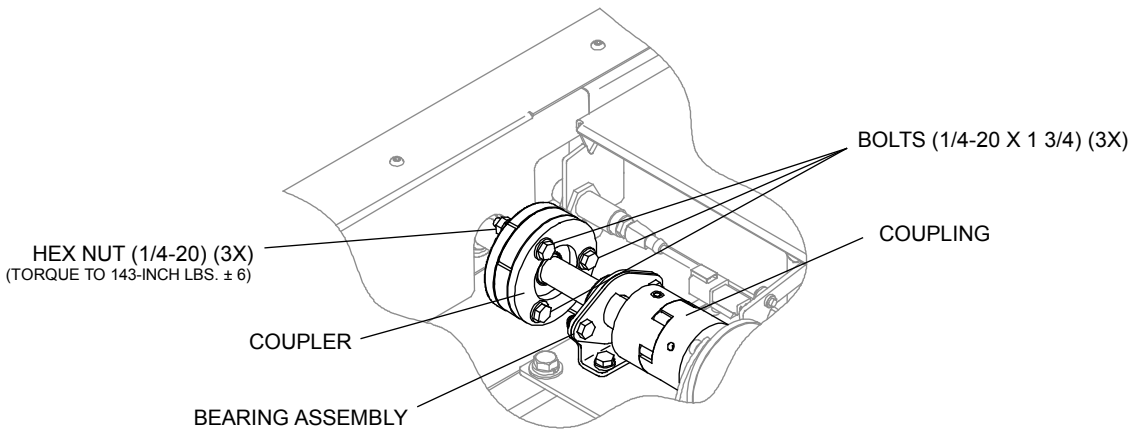

RSM0065300

**FIGURE 2-11: ADJUSTABLE COUPLER**

- b. Adjust Chain Assembly to align and balance chain tension.
- c. Set torque wrench to 143 inch-lbs.

**NOTE:** Ensure the torque wrench is calibrated before each use.

- d. Refer to **Figure 2-11**. Torque each of three coupler hex nuts to 143 inch lbs ± 6 inch lbs.

**NOTE:** Secure bolt (1/4-20 X 1 3/4) with a box end wrench to prevent bolt from rotating while torque is applied.

- e. Use a black fine point marker and write torque value near each of three nuts that have been torqued.

**5. TIMING ADJUSTMENT**

The stow/deploy timing is associated to the overall function of the ramp stow and deployment and aids in the control of the ramp self-alignment. The ramp stow/deploy timing is pre-adjusted at the factory. In the

event any components such as the motor, drive shaft, or CAMs are replaced, the deployment timing must be adjusted.

**NOTE:** The stow/deploy timing must be adjusted with the unit starting in the stowed position. Therefore, the ramp assembly must be removed from the vehicle and placed onto a workbench or work stand to access enclosure components. Moving the ramp assembly to a workbench or work stand may require two people.

Follow all safety requirements before proceeding with any of the following procedures.

- Remove power from ramp or vehicle.
- Refer to **Figure 2-8**. Refer to Section B.3, step a through step g (CAM Shaft Replacement) to remove ramp tray from enclosure.
- Remove Front Cover Assembly.
- Refer to **Figure 2-12**. Turn the motor to line up CAM Shafts and chain assembly to simulate ramp tray in fully stowed position.

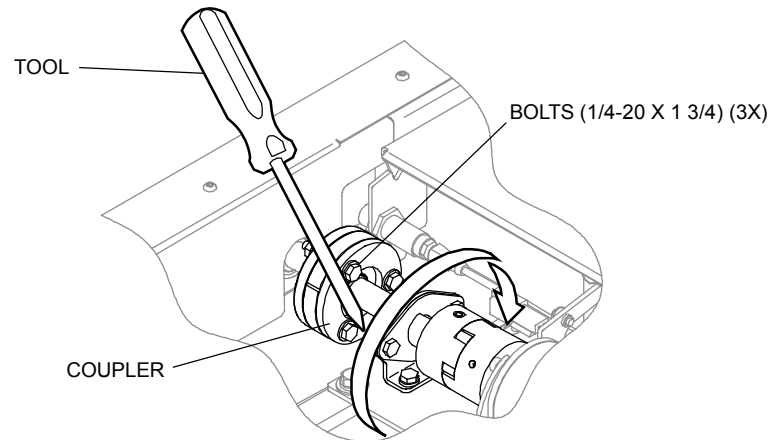

RSM0065900

**FIGURE 2-12: TURN MOTOR**

**NOTE:** Use a tool to carefully turn the motor clockwise (CW) to turn the CAM shaft to the fully stowed position. Ensure sprocket and chain assembly marking is also aligned to the fully stowed position.

- Once the CAM shaft and Chain Assembly are aligned, refer to Section B.4 (Coupler Adjustment) follow procedure to adjust coupler.
- Loosen but do not remove set screw.
- Refer to **Figure 2-13**. Turn Spiral Plate clockwise (CW) so that Rod Switch travels to end of slot.

**NOTE:** Turning Spiral Plate to end of slot aligns the ramp tray in the fully stowed position.

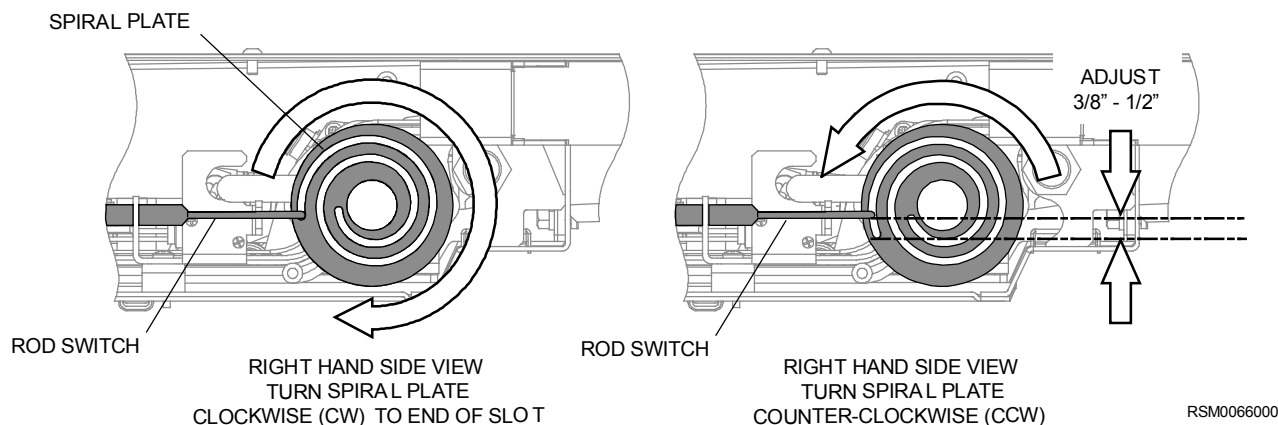

RSM0066000

**FIGURE 2-13: SPIRAL PLATE**

- Turn Spiral Plate counter-clockwise (CCW)  $3/8''$ - $1/2''$  to allow for motor overdrive.

**CAUTION**

Leaving the Spiral Plate at the end of the slot without adjusting for motor overdrive can cause damage to the Spiral Plate and to the system. Turn the Spiral Plate  $3/8''$ - $1/2''$  to allow for motor overdrive.

- i. Tighten set screw to secure Spiral Plate.
- j. Refer to **Figure 2-14**. Turn the motor counter-clockwise (CCW) to align the CAM shafts to a horizontal position. This will allow for installation of the ramp tray.

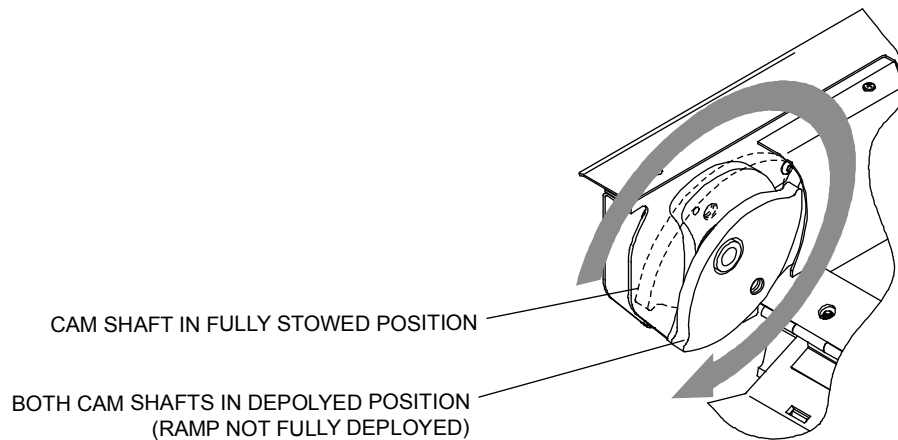

RSM0066100

**FIGURE 2-14: CAM SHAFT DEPLOYED TO HORIZONTAL POSITION**

- k. Refer to **Figure 2-8**. Install ramp tray with two (2) platform pivot screws and two (2) thrust washers.
- l. Attach front ramp cover to ramp tray.
- m. Refer to **Figure 2-15**. Apply power to ramp then raise ramp tray to vertical position.

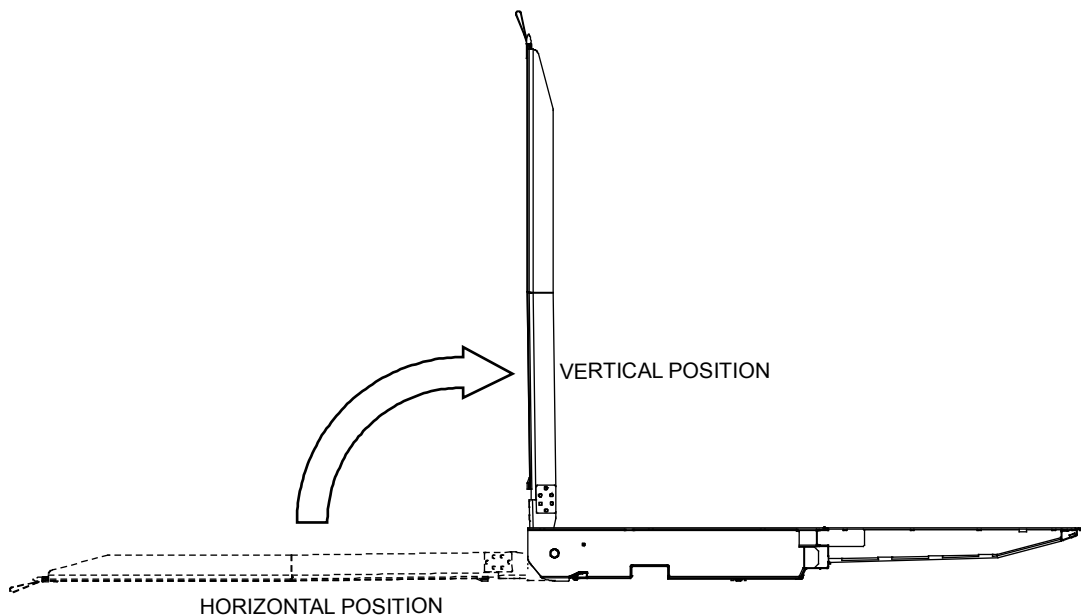

RSM0066200

**FIGURE 2-15: RAMP TRAY ROTATED TO VERTICAL POSITION**

- n. Locate Spiral Switch Plunger and inspect location and position. If the Spiral Switch Plunger is off of position from Limit Switch (Stow) as shown in **Figure 2-16**, then adjustment is necessary.
- o. Refer to **Figure 2-16**. Loosen the Spiral Switch Plunger set screw. Move Spiral Switch Plunger up or down as necessary so that the limit switch is set for fully stowed position.



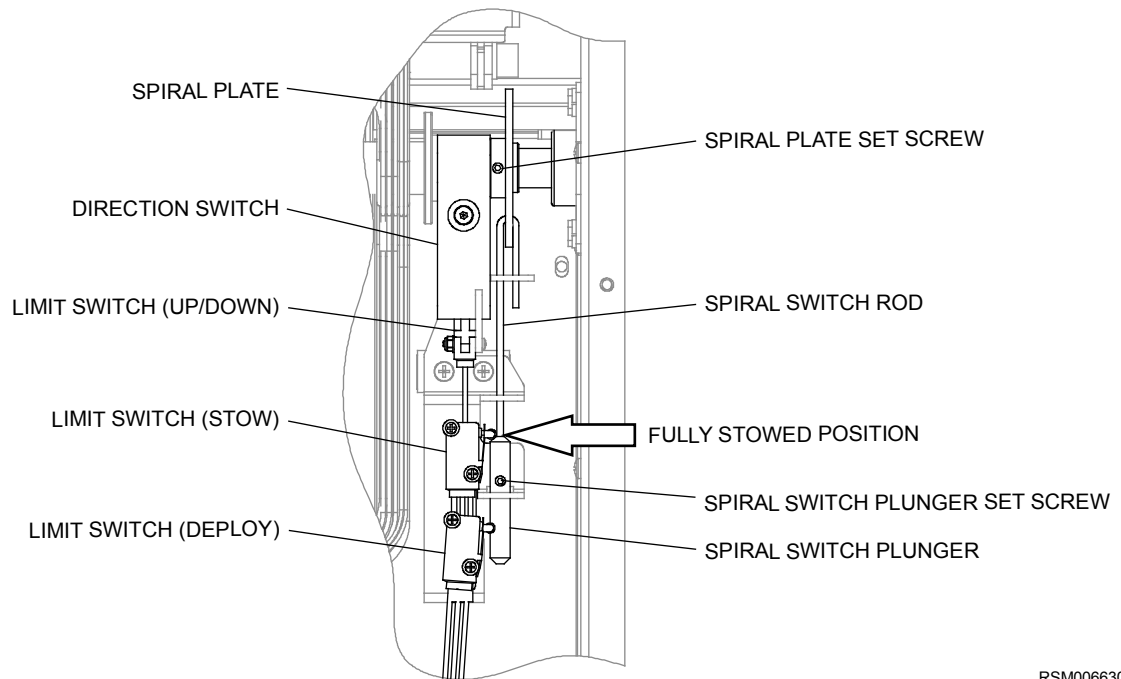

RSM0066300

**FIGURE 2-16: LIMIT SWITCH ADJUSTMENT**

- p. Deploy ramp tray to its fully deployed position. If the Spiral Switch Plunger is off of position from Limit Switch (Deploy) as shown in **Figure 2-17**, then adjustment is necessary.
- q. Tighten Spiral Switch Plunger set screw.

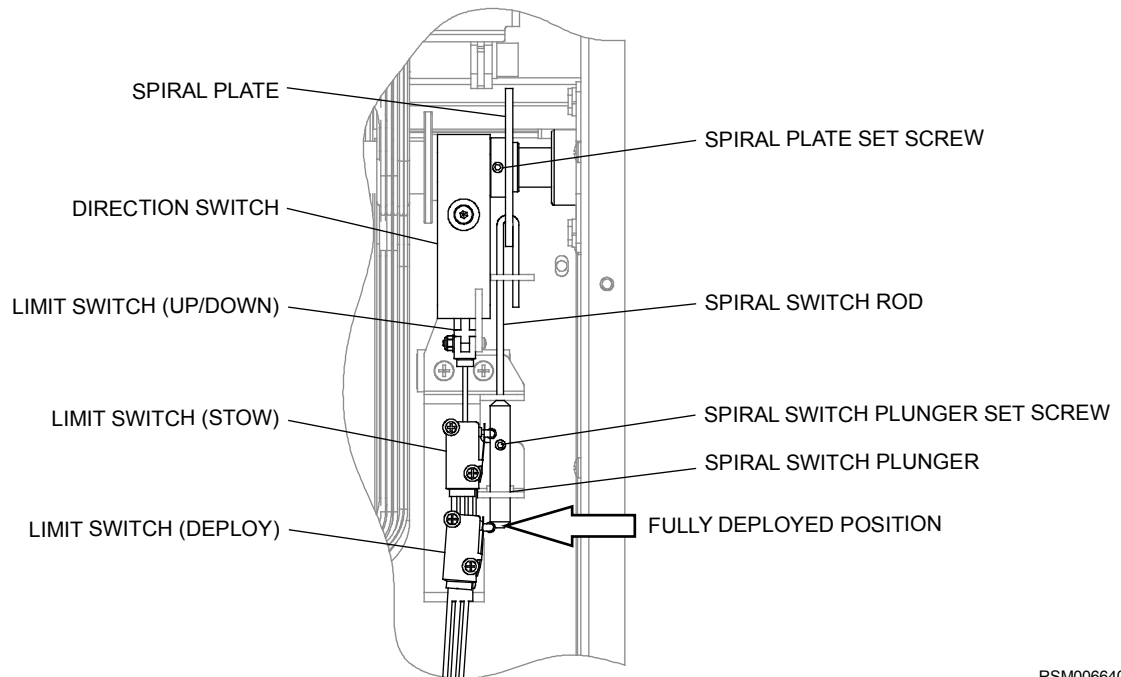

RSM0066400

**FIGURE 2-17: LIMIT SWITCH ADJUSTMENT**

- r. Refer to **Figure 2-17**. Loosen the Spiral Switch Plunger set screw. Move Spiral Switch Plunger up or down as necessary so that the limit switch is set for fully deployed position.
- s. Tighten Spiral Switch Plunger set screw.
- t. Cycle the ramp in the stowed and deployed position 2-3 cycles.
- u. Ensure all enclosure components are working properly without binding.
- v. Re-install slanted ramp plate cover.
- w. Remove power from ramp assembly.
- x. Re-install ramp assembly into vehicle.



## 6. SENSOR TARGET ADJUSTMENT FOR POSITION AND GAP

- Verify that the ramp is completely stowed. This establishes a reference position for ramp during target adjustment.

**NOTE:** Use a straightedge as an artificial target to simulate ramp tray barrier when fully stowed.

- Refer to **Figure 2-18**. Loosen jam nuts on sensor body. Adjust position of both nuts to achieve a gap between nose of sensor and outside diameter of target that is  $0.06" \pm 0.03"$  (gap is set on inside of ramp tray barrier). Do not allow sensor to contact target. Tighten jam nuts and recheck gap.

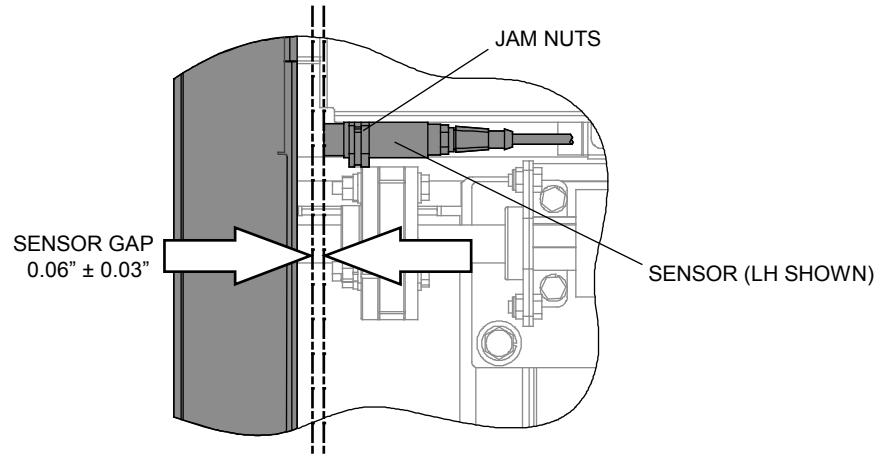

RSM0065400

**FIGURE 2-18: SENSOR GAP ADJUSTMENT (LH SIDE SHOWN)**

## 7. FINAL INSPECTION

- Visually inspect ramp for loose or missing hardware and fittings, and confirm that pockets are free of debris.
- Verify that slanted plated cover is secure and closed on ramp.
- Verify that non-skid flooring is clean, functional, and securely fastened.
- Verify that manual operation strap is undamaged.

### III. FOLDOVER® SSR-SERIES SINGLE-SLOPE RAMP MAINTENANCE

The maintenance information in this chapter applies to the Ricon SSR-Series FoldOver® Single-Slope ramp when installed in transit vehicles. The information consists of safety precautions, a maintenance schedule, component information, and diagrams for the electrical system. This chapter is intended to supplement related sections of the vehicle manufacturer Owner Manual and Quick-Start Guide.

#### A. GENERAL SAFETY PRECAUTIONS



#### WARNING!

THIS RAMP IS DRIVEN WITH AN ELECTRO-MECHANICAL MOTOR DRIVE SYSTEM. USE EXTREME CAUTION WHEN DOING MAINTENANCE AND REPAIRS. DO NOT DISCONNECT ELECTRICAL CABLES OR FITTINGS WHEN RAMP IS IN MOTION OR WHEN POWER IS APPLIED TO THE RAMP.

Follow these safety precautions during service of the Ricon FoldOver Single-Slope ramp:

- Under no circumstances is maintenance, repair, or adjustment of the FoldOver Single-Slope ramp to be performed without the presence of an individual capable of giving aid.
- Give immediate attention to all injuries, and administer first-aid or seek medical attention as necessary.
- Protective eye shields and clothing should be worn during maintenance, repair, and adjustment of the FoldOver Single-Slope ramp.
- The user must be cautious when operating the ramp. Be certain that hands, feet, legs, and clothing are not in the path of ramp movement.
- Batteries contain acid that can burn. Wear protective clothing and eye protection at all times. If acid comes in contact with skin, immediately flush affected area with water and wash with soap. Do not place anything electrically conductive on top of battery. Do not smoke or use an open flame near battery.
- Work in a properly ventilated area.
- Read and understand all instructions before attempting to operate the FoldOver Single-Slope ramp.
- Inspect the ramp before use for unsafe conditions, unusual noises, or erratic movements. Do not use ramp if any of these are present, and arrange to have a Ricon dealer or qualified service technician inspect ramp.
- Keep others clear of the ramp while it is operating.
- Ricon strongly recommends that the vehicle be parked on level ground when using ramp. Using the ramp when vehicle is sloped may result in a ramp angle that is too steep for safe use. In addition, the sloped vehicle may not allow the ramp to make complete contact with the ground.
- The FoldOver Single-Slope ramp and other system components require periodic maintenance. Ricon recommends a thorough vehicle inspection by a Ricon dealer or qualified service technician at least once every six months. To maximize safety, the ramp and related components should be maintained at their highest level of performance.
- Read and comply with warning labels attached to ramp.

**B. DAILY INSPECTION**

Check ramp daily, following the Daily Inspection outlined in **Table 3-1**. Meet all inspection criteria before allowing passengers on ramp.

TABLE 3-1: DAILY INSPECTION	
INSPECTION POINT	CHECK
Ramp controller	<ul style="list-style-type: none"> <li>• Power ON/OFF switch operates correctly.</li> <li>• Power On indicator illuminates when Power ON/OFF switch is ON.</li> <li>• DEPLOY and STOW switches operate correctly.</li> <li>• No unusual noises or erratic movements when ramp is deploying or stowing.</li> </ul>
Ramp and surrounding area	Vestibule area is free of loose objects and trim pockets are free of debris.
Ramp non-slip surfaces	<ul style="list-style-type: none"> <li>• Surface is clean and free of slippery or sticky substances that could compromise user safety.</li> <li>• Surface is intact and secure, and loose edges, if present, cannot create a stumbling hazard.</li> </ul>
<b>END OF TABLE</b>	

**C. MAINTENANCE SCHEDULE**

Regular maintenance and inspection of the Ricon FoldOver Single-Slope ramp provides optimum performance and reduces the need for repairs. Maintain the ramp as directed in **Table 3-2**. Perform ramp maintenance more frequently during heavy use (more than 20 cycles per day).

<b>⚠ CAUTION!</b>
~ This Ricon Product Is Complex ~
Required warranty period maintenance and repairs must be done at a Ricon dealer or qualified service facility. Improper maintenance, use of non-Ricon replacement parts, or product modification will void warranty and can result in unsafe operating conditions. We recommend that a Ricon dealer or qualified service facility continue maintenance inspections when warranty ends.

TABLE 3-2: MAINTENANCE SCHEDULE	
INSPECTION POINT	ACTION
<b>– 6,000 MILE INSPECTION –</b>	
Electrical System	Check all electrical cables and fittings; tighten or replace as necessary
Cover Fasteners	Check all threaded fasteners for looseness, and retighten as necessary.
Non-slip surface	Visually check for damage to surface, and for loose or missing non-slip material.
Ramp Interior	Visually check ramp interior area and remove accumulated dirt and debris.
Decals	Visually check for illegibility or damage, replace as necessary.
<b>– 12,000 MILE INSPECTION –</b>	
Wiring harnesses	Check wiring insulation for heavy abrasions, and connectors for looseness. Replace as necessary.
Fasteners	Check all threaded fasteners for tightness and retighten as necessary.
Non-slip surfaces	Check non-slip surface for excessive wear or damage (rips, tears, peeling, etc.), and replace as necessary.

TABLE 3-2: MAINTENANCE SCHEDULE	
INSPECTION POINT	ACTION
<b>– 24,000 MILE INSPECTION –</b>	
Self-Aligning Assembly	Grease or oil to lubricate parts is NOT recommended. Keep components clean and free of debris. Refer to installation section for self-aligning assembly replacement.
<b>END OF TABLE</b>	

**D. RAMP COMPONENT INFORMATION**

Ricon FoldOver Single-Slope Ramp uses electrical power from the host vehicle to deploy and stow the ramp. Vehicle electrical power is converted to mechanical force, which is used to move the ramp. Electrical components are described below. Please refer to **Figure 3-4** for electrical diagram.

**1. MOTOR DRIVE SYSTEM**

The ramp employs an electro-mechanical motor drive system (contained within the ramp enclosure). Settings are programmed in the motor drive system and is preset at Ricon.

Ricon recommends operating the ramp while the vehicle engine is running in order to minimize current drain on the vehicle battery.

**2. SELF-ALIGNING ASSEMBLY**

Two factory adjusted self-aligning assemblies control the Stow and Deploy motion of the FoldOver Single-Slope ramp. Their adjustment determines the degree to which the ramp will rotate opened or closed.

**3. ELECTRONIC CONTROLLER**

The electronic controller interprets DEPLOY and STOW requests and controls ramp functions. It contains integrated circuits (ICs), relays, fuses, and associated parts. The ICs cannot be accessed externally. The 55-pin ramp connector receives 24V to power the controller and sends 24V to power the motor drive system.

Refer to **Figure 3-1** for connector and controller connection. Controller only requires one 55-pin connector connection.

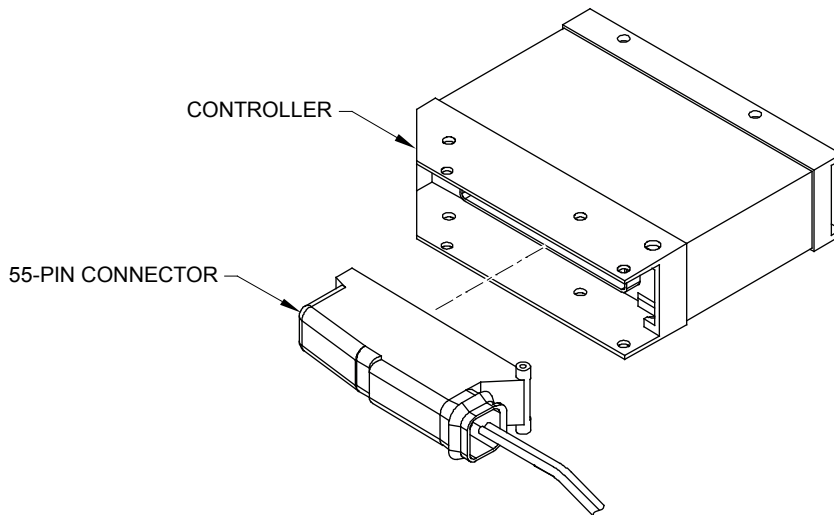

RSM0030600

**FIGURE 3-1: CONTROLLER**

**NOTE:** Voltage levels are 24 to 28 VDC in this application.

**4. SENSOR LIGHT ACTIVITY DURING RAMP MOVEMENT**

The FoldOver Single-Slope ramps has two ramp positions that are monitored by the controller. These positions are fully stowed and deployed position. The ramp must be in the fully stowed area before the electrical interlock output signal will turn on (24VDC). This is done to reduce the possibility of a passenger

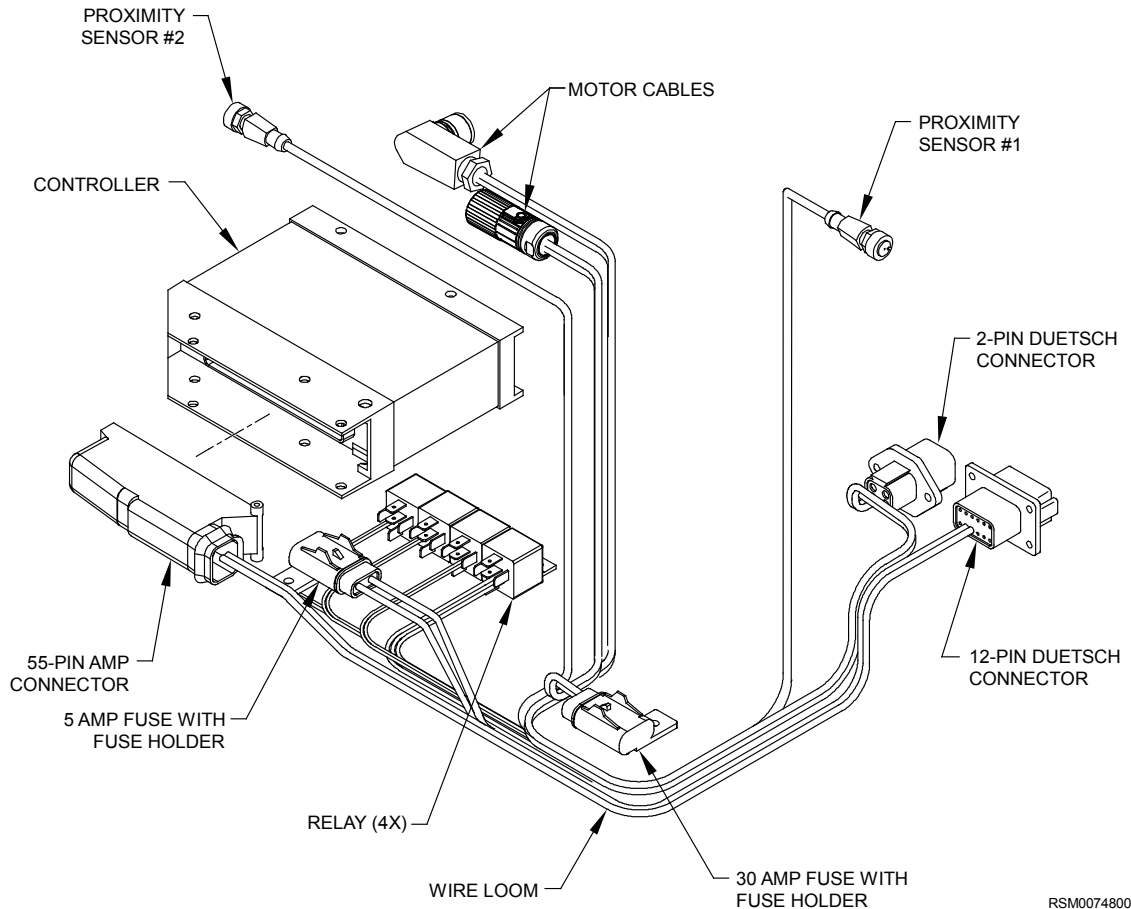

RSM0074800

tripping on the front edge of the ramp when it is not stowed completely as well as preventing the bus from operating or moving when ramp is deployed.

Refer to **Table 3-3**. The status of the sensor lights (on or off) and the interlock output (0VDC or 24VDC) occur when the ramp is either STOWED or DEPLOYED. Note that the interlock output has both a normal and an inverted output. This table applies to the normal output.

TABLE 3-3: SENSOR LIGHT AND INTERLOCK OUTPUT STATUS			
POSITION	DEPLOY LIGHT	STOW LIGHT	INTERLOCK OUTPUT
STOWED	OFF	OFF	0VDC
DEPLOYED	ON	OFF	24VDC
End of Table			

**5. CIRCUIT BREAKERS AND FUSES**

The bus builder installs a 50-amp circuit breaker for 24V applications to protect ramp control circuits. Refer to **Table 3-4** for harness fuses.

**6. ELECTRICAL DIAGRAMS**

Refer to **Figure 3-2** for a description of plug and receptacle designations used on schematic.

Refer to **Figure 3-4** for an overall wiring diagram of the ramp system. The wiring diagram is located at the end of this chapter.

FIGURE 3-2: CONNECTOR CONFIGURATION

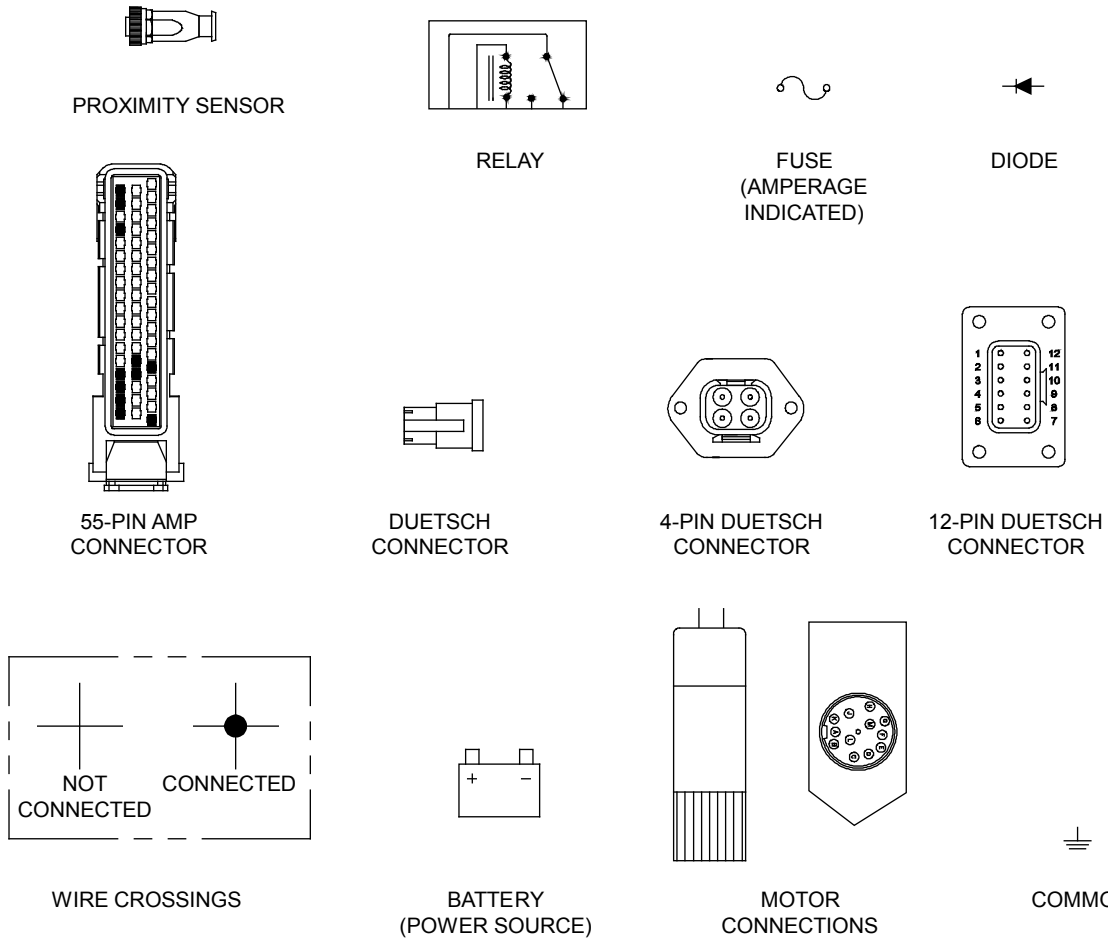

RSM0043700

FIGURE 3-3: SCHEMATIC SYMBOLS

TABLE 3-4: HARNESS FUSES		
FUSE	RATING	CIRCUIT
F1	5 AMP	Lift Enable (Ramp Switch)
F2	30 AMP	24V High Voltage (Motor Power)
END OF TABLE		

E. WIRING DIAGRAM

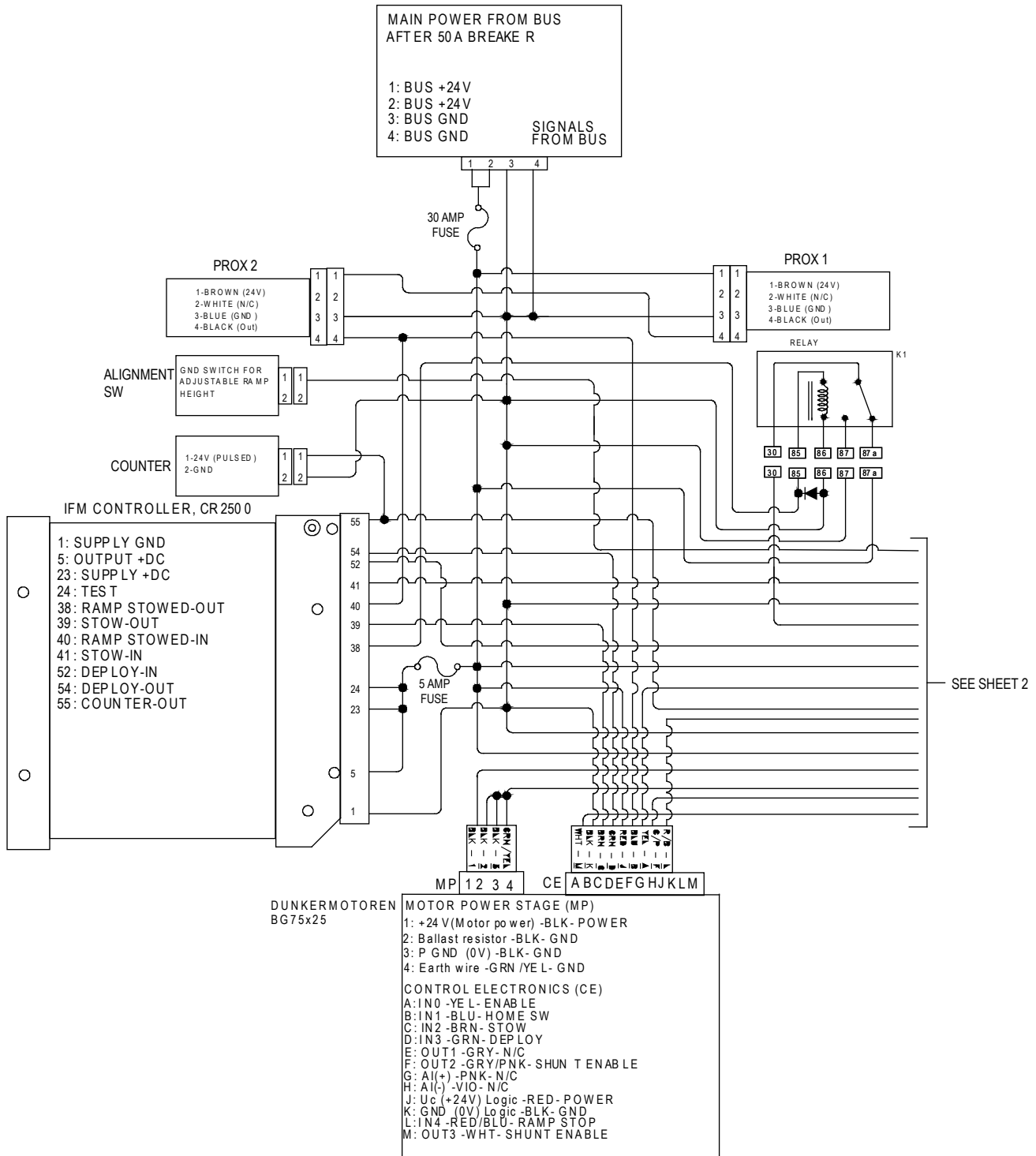
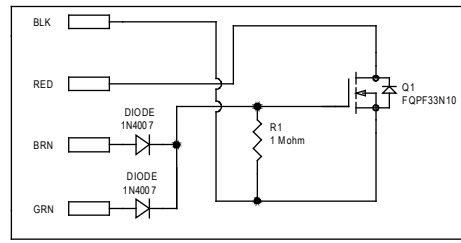
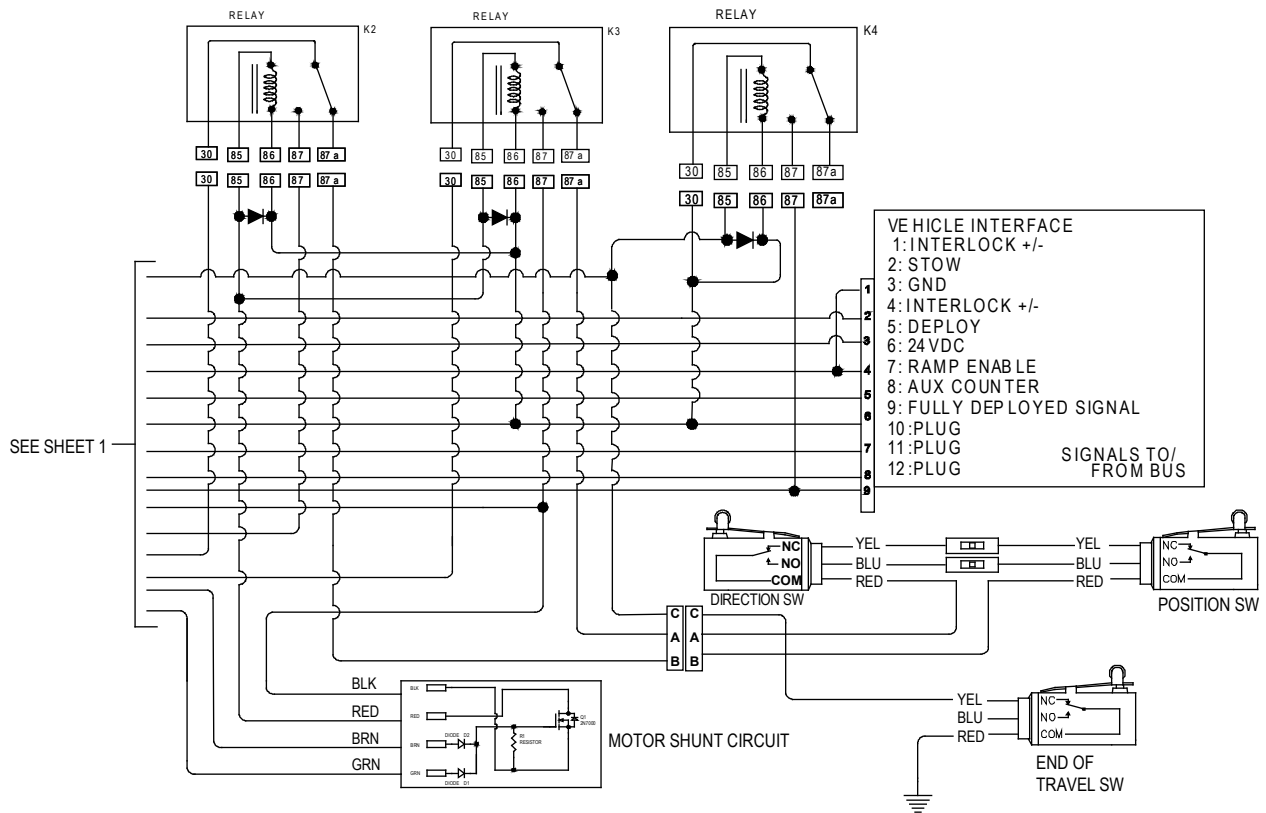

FIGURE 3-4.1: SSR-SERIES SINGLE-SLOPE RAMP HARNESS DIAGRAM (SHEET 1 OF 2)

RSM0061300



DETAIL A



SEE SHEET 1

RSM0061400

FIGURE 3-4.2: SSR-SERIES SINGLE-SLOPE RAMP HARNESS DIAGRAM (SHEET 2 OF 2)



This page intentionally left blank.

### IV. FOLDOVER® SSR-SERIES SINGLE-SLOPE RAMP SPARE PARTS

The parts layouts and lists in this chapter apply to the Ricon FoldOver® SSR-Series Ramp when installed in a transit vehicle. Replaceable ramp parts are illustrated in exploded views of major lift assemblies, which show smaller assemblies and components with reference numbers. Each associated parts list contains reference numbers, parts descriptions, and Ricon part numbers.

Each accompanying parts list contains figure item numbers, part descriptions, quantities used, configurations, and the Ricon part number. To order parts, locate part on an appropriate diagram and note the figure item number. Find the figure item number on the accompanying parts list and use the part number in the far right column. Note that parts identified with (REF) in the QTY column of the spare parts list are for reference purposes only and are not sold for spare parts.

**NOTE:**

- Most items that are described as “kits” contain a single part (plus hardware). Therefore, you may need to order more than one kit if the part is used more than once on the assembly shown.
- Small, inexpensive hardware items are supplied in a minimum quantity of ten, and are packaged in a bag. A single bag may provide more parts than you need, or you may need multiple bags when working on a large assembly. The QTY column indicates how many individual parts are used on the assembly shown; you will need to determine the number of bags required for your task.
- The reference numbers for some parts have more than one part number listed. This occurs when variations of a part are used on different ramp models. These parts are followed by a model designation (SSR00, etc).

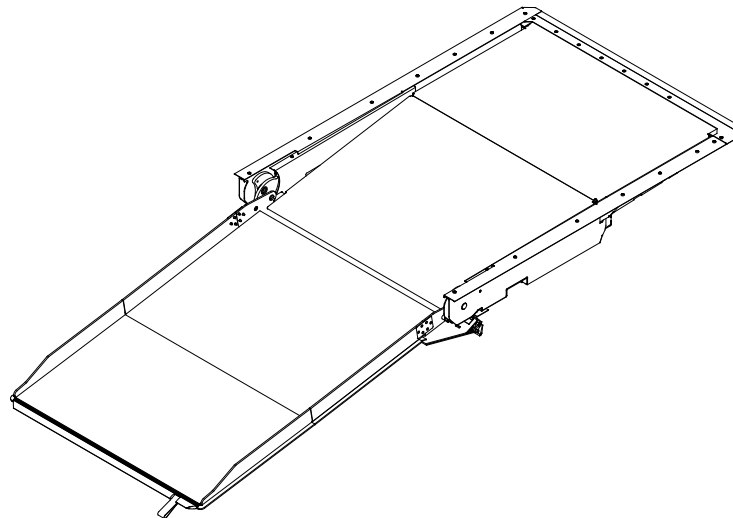

PRODUCT MODEL AND KIT NUMBERS	
PRODUCT NUMBER	SSR
DOCUMENTATION KIT NUMBER	55405

**PARTS DIAGRAMS**

**PAGE**

FIGURE 4-1: SSR-SERIES DECAL PART NUMBERS AND LOCATIONS ..... 4-2

FIGURE 4-2: SSR-SERIES RAMP ASSEMBLY ..... 4-4

FIGURE 4-3: SSR-SERIES MOTOR DRIVE ASSEMBLY ..... 4-10

FIGURE 4-4: SSR-SERIES ELECTRICAL HARNESSES AND CONNECTORS ..... 4-12

**LIFT SPECIFICATIONS ..... 4-15**

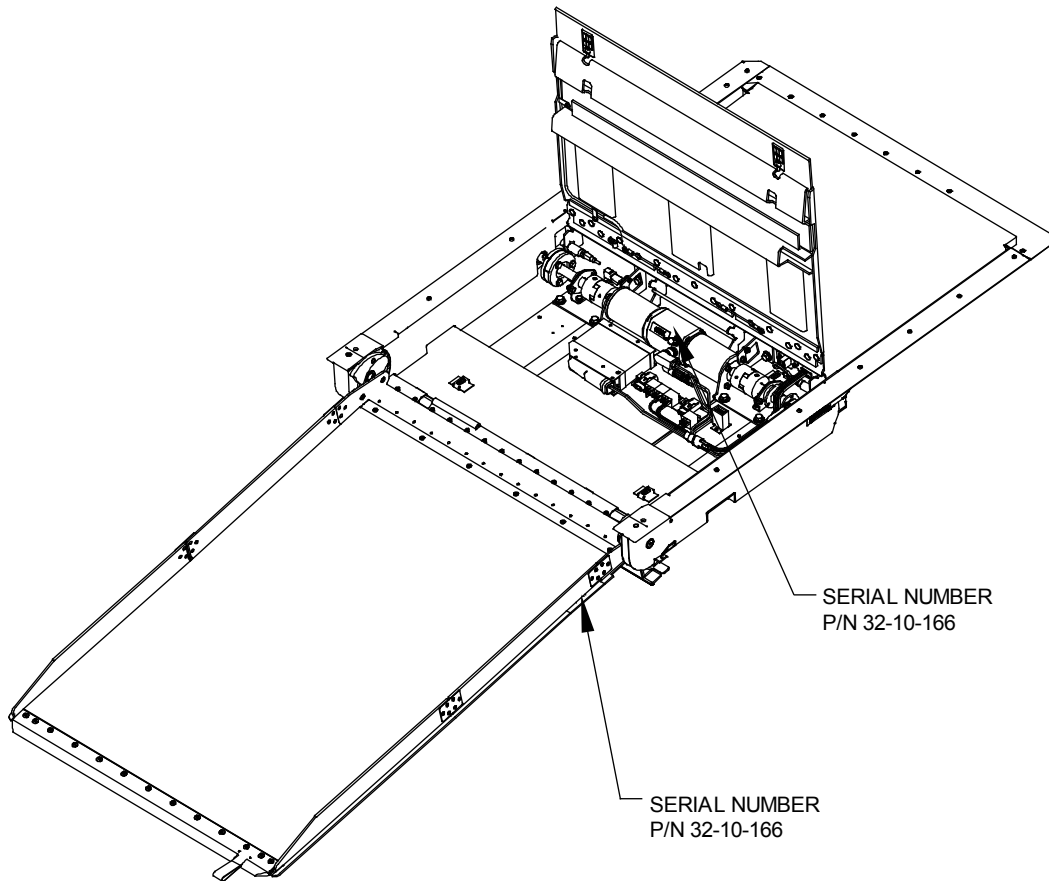

RE 4-1: SSR-SERIES DECAL PART NUMBERS AND LOCATIONS

RSM0074900 FIGU

This page intentionally left blank.

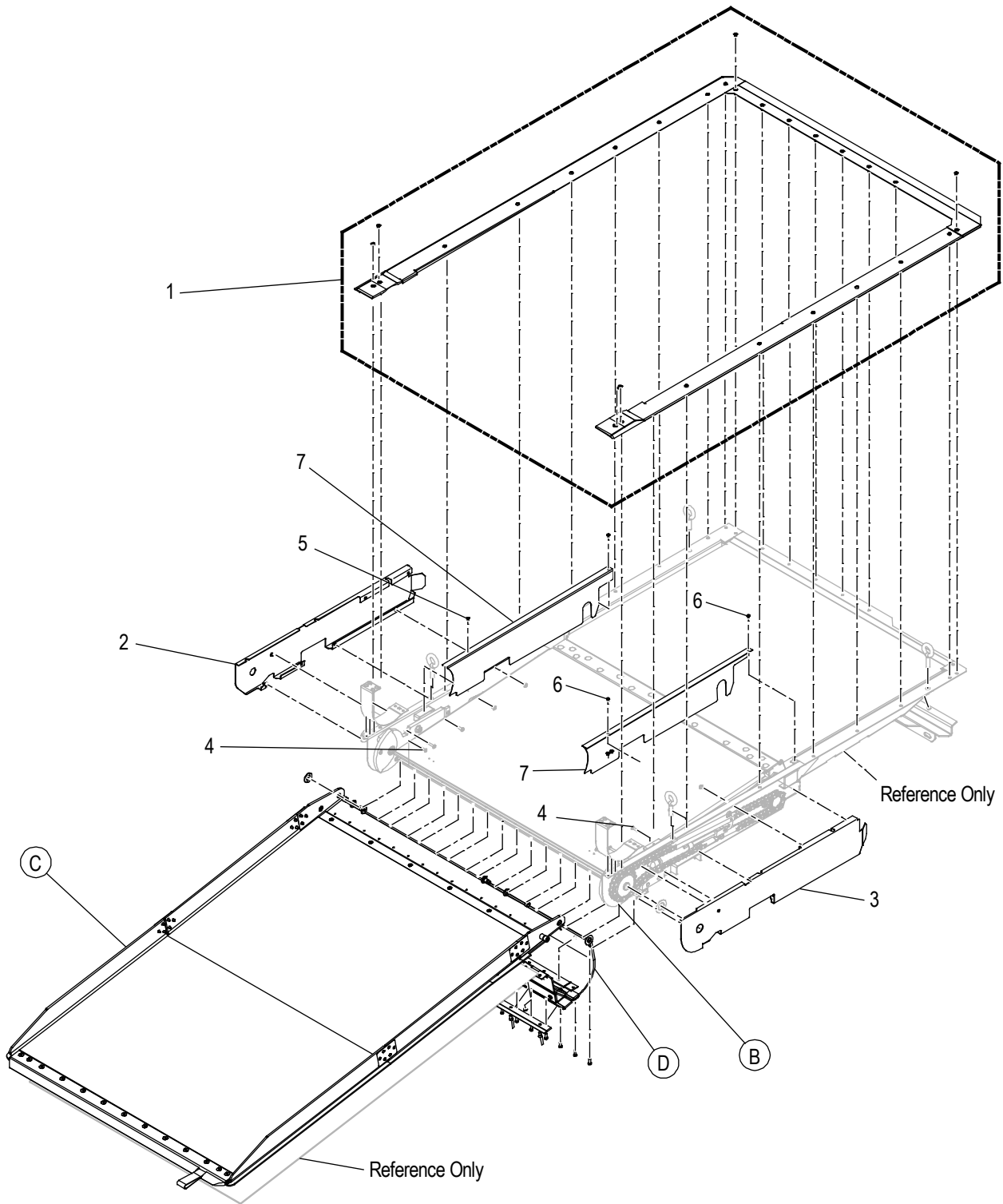

FIGURE 4-2.1: SSR-SERIES RAMP ASSEMBLY (SHEET 1 OF 4)

RSM0075000

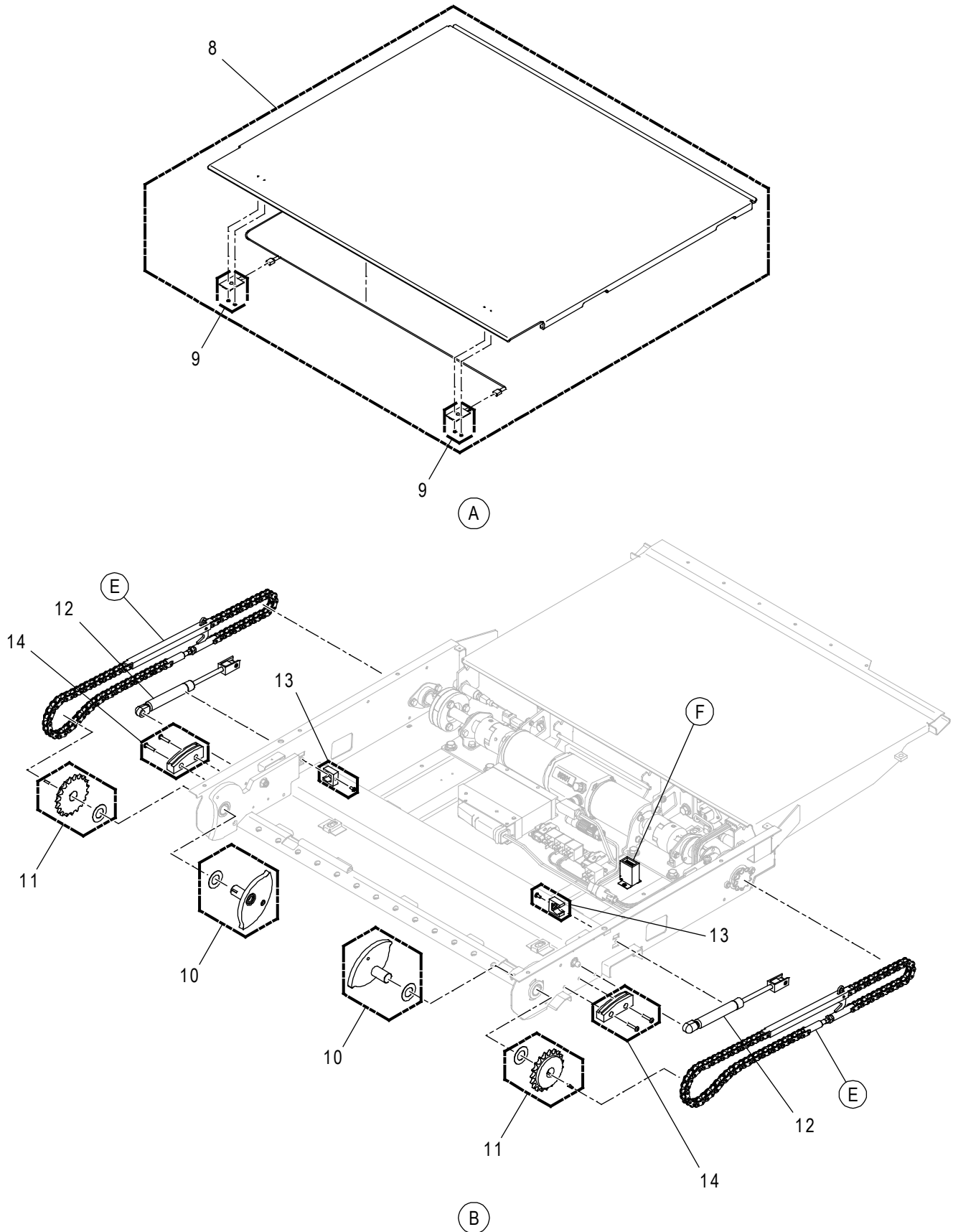
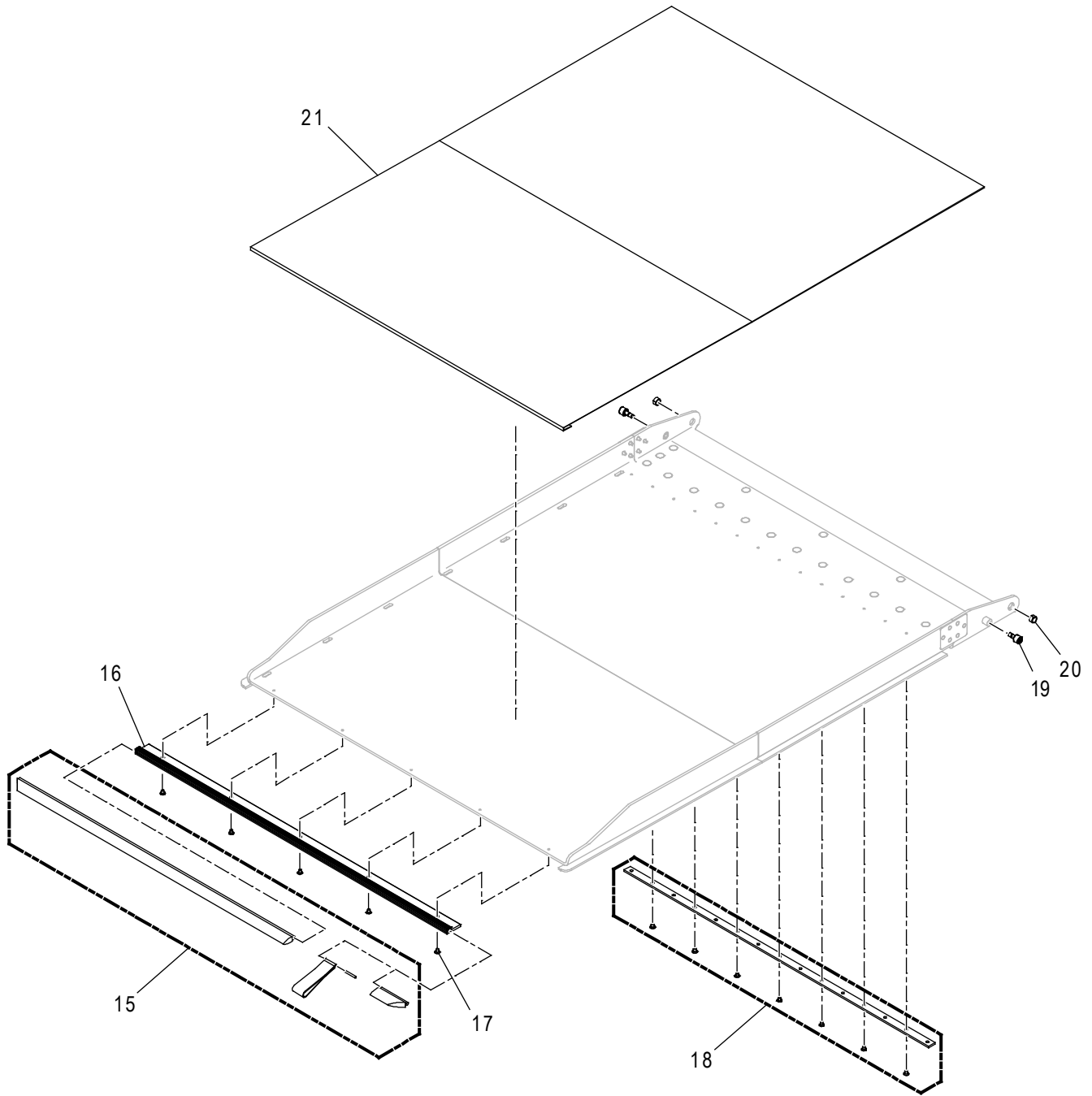

FIGURE 4-2.2: SSR-SERIES RAMP ASSEMBLY (SHEET 2 OF 4)

RSM0075300



(C)

RSM0075400

FIGURE 4-2.3: SSR-SERIES RAMP ASSEMBLY (SHEET 3 OF 4)

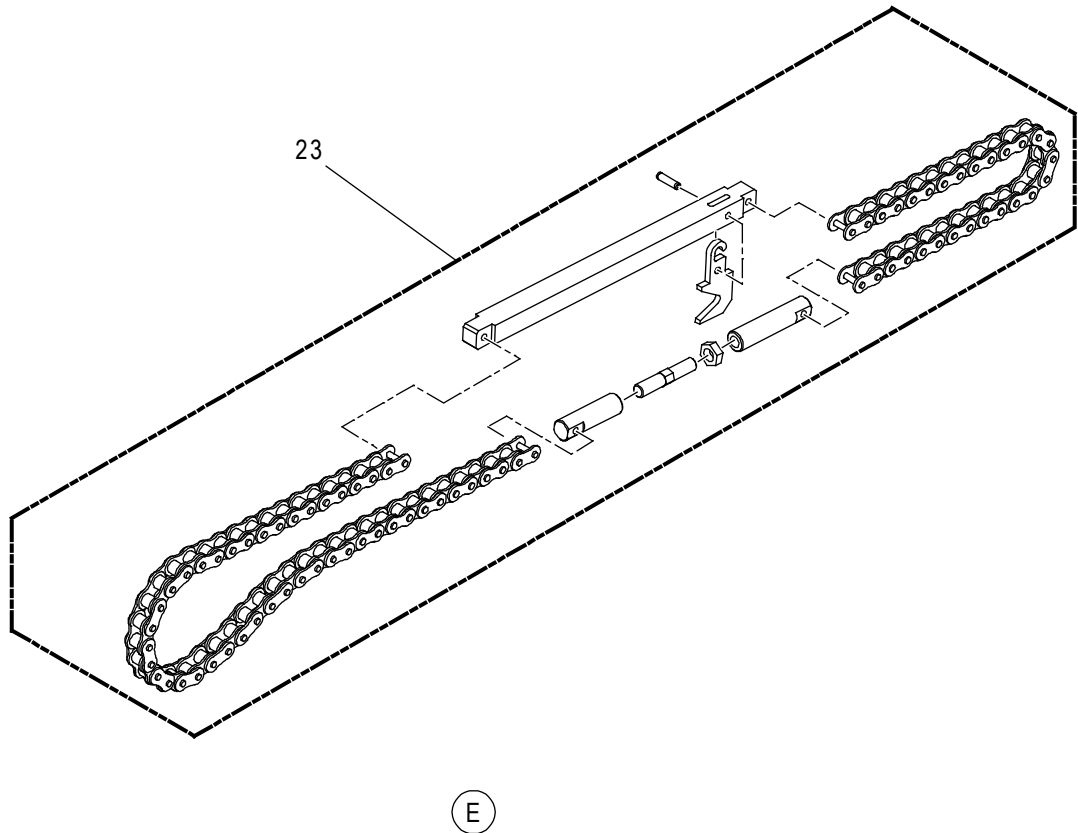
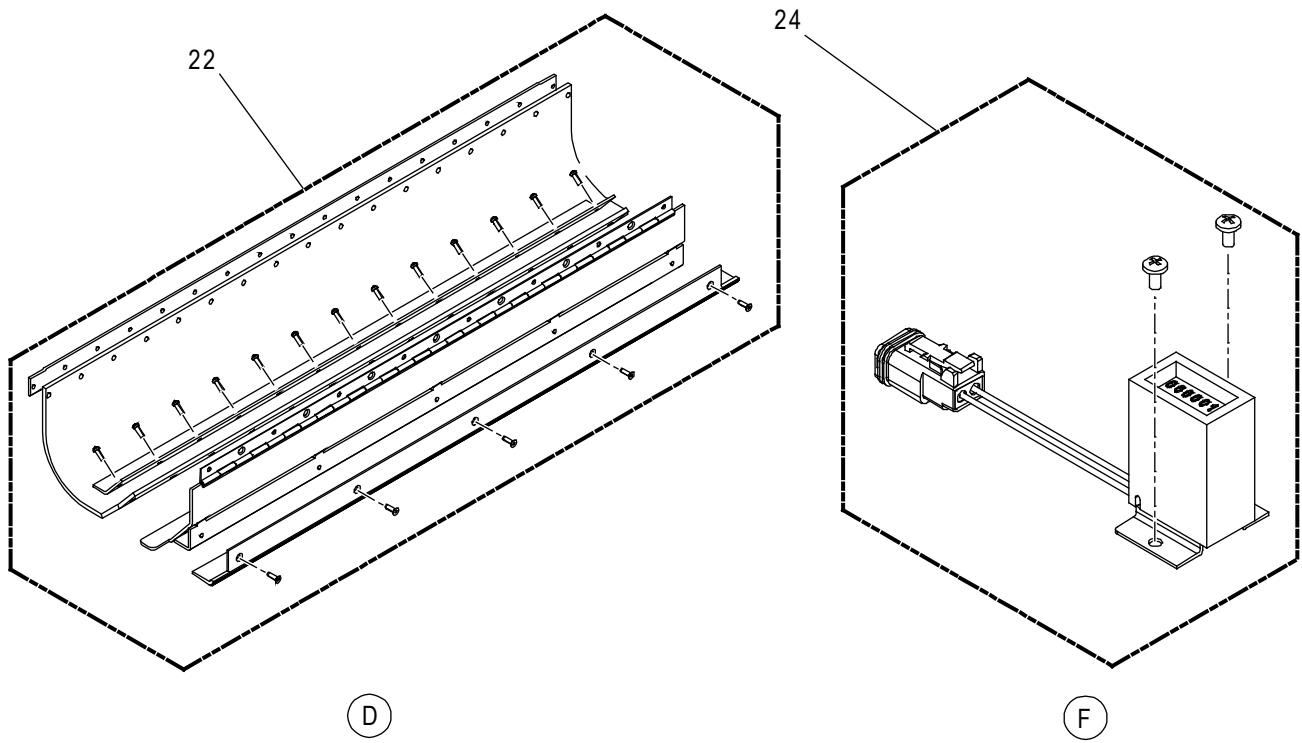

FIGURE 4-2.4: SSR-SERIES RAMP ASSEMBLY (SHEET 4 OF 4)

RSM0075100



This page intentionally left blank.

FIGURE 4-2: SSR-SERIES RAMP ASSEMBLY

FIG. ITEM	DESCRIPTION	QTY	CONFIG.	PART NO.
1	KIT, FLANGE, RUBBER GATE	1		59048
2	COVER, CHAIN, RUBBER GATE, LH	1		56696
3	COVER, CHAIN, RUBBER GATE, RH	1		56697
4	SCREW, FHP, 10-24 x 5/8 SST (BAG OF 10)	2		28122
5	COVER, CHAIN, LH	1		42744
6	COVER, CHAIN, RH	1		42776
7	SCREW, PHP, 6-32 x 1/4 MS SST (BAG OF 10)	4		280425
8	KIT, FLOOR ASSY	1		56675
	KIT, FLOOR ASSY	1		60792
9	KIT, SWITCH ASSY	2		55465
10	KIT, CAM, SHAFT	2		55466
11	KIT, SPROCKET, NO.40, 19 TEETH, MACHINED	2		55467
12	KIT, GAS SPRING	2		46513
13	KIT, SPRING GUIDE	2		55468
14	KIT, CHAIN GUIDE	2		55469
15	KIT, RUBBER EXTRUSION WITH LOOP HANDLE	1		55473
16	KIT, EXTRUSION, ALUMINUM, 29.50" LONG	1		55474
17	SCREW, FHP, 10-24x1/4 UNDERCUT (BAG OF 10)	5		55475
18	KIT, BAR, SPACER, FRONT GATE WITH HARDWARE	1		55476
19	CAM Follower, 1/2"DIA ROLLER, 1/4"DIA STUD (BAG OF 2)	1		55477
20	BEARING, DU, 06DU04 (BAG OF 2)	2		56634
21	*** SAFETREAD, 4FT x 60FT, BLK, 3M #310	REF		17792
22	KIT, FRONT COVER ASSEMBLY WITH HARDWARE	1		61527
23	KIT, CHAIN ASSEMBLY	2		61729
24	KIT, COUNTER & CONNECTOR ASSY, WITH HARDWARE	1		44219

**NOTE:** (REF) in QTY column is for Referenced Parts Only and are not sold as spare parts.

**NOTE:** \* Item or configuration not shown.

**NOTE:** \*\* Some applications require alternate flange trim for alternate applications. Refer to Config. Column for alternate applications.

**NOTE:** \*\*\* Platform Assembly for reference only. Flooring and extruded parts are assembled in the factory. Contact Product Support.

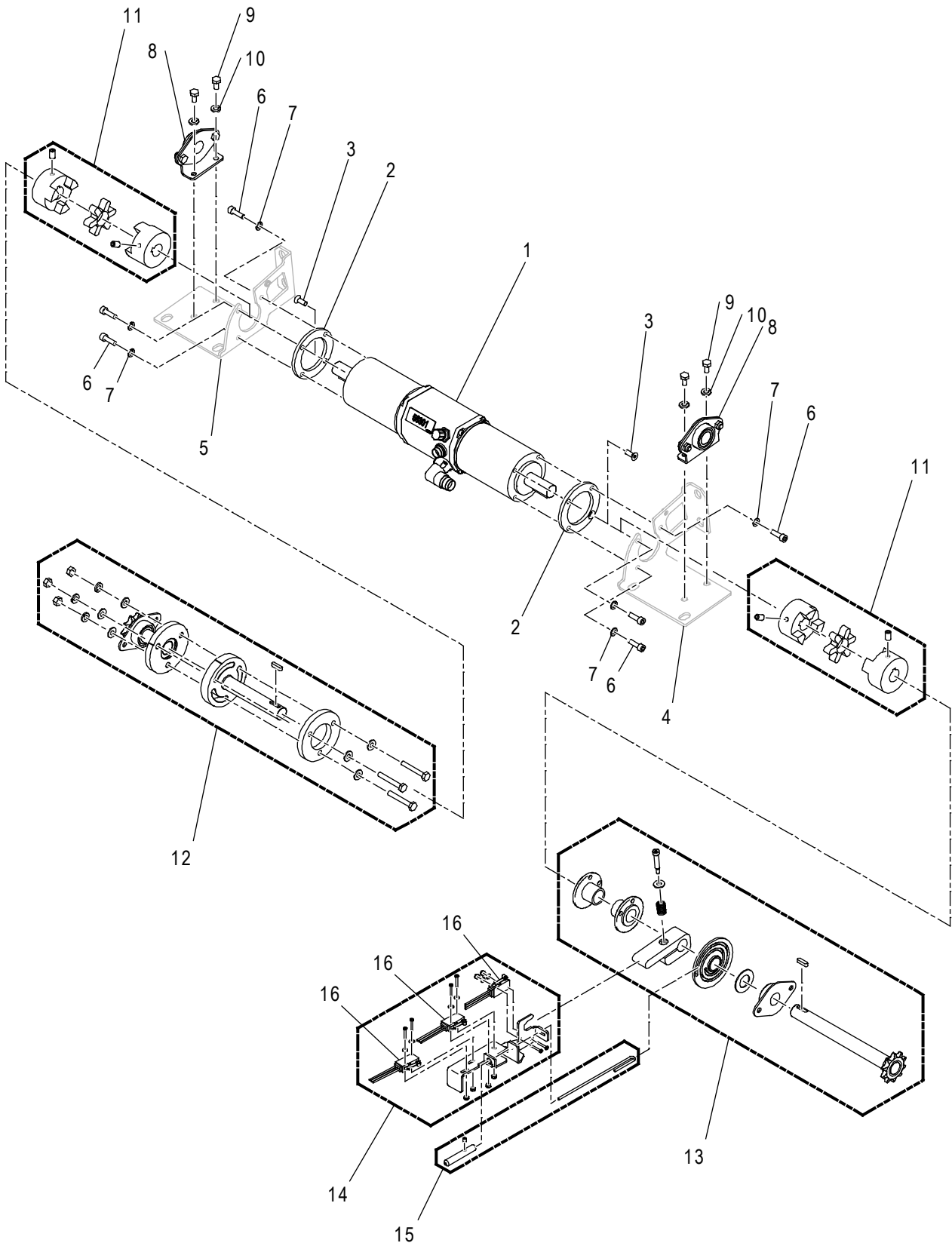

RSM0075500

FIGURE 4-3: SSR-SERIES MOTOR DRIVE ASSEMBLY

FIGURE 4-3: SSR-SERIES MOTOR DRIVE ASSEMBLY

FIG. ITEM	DESCRIPTION	QTY	CONFIG.	PART NO.
1	MOTOR, DUAL GEAR BOX ASSY, PROGRAMMED	1		56301
2	SPACER, GEAR MOTOR	2		43960
3	SCREW, FHH, M6-1 X 16MM SST	REF		19217
4	BRACKET, MOTOR MOUNT LEFT HAND	REF		55375
5	BRACKET, MOTOR MOUNT RIGHT HAND	REF		55374
6	SCREW, SHC, M6-1.0 X 20MM LNG, SST (BAG OF 10)	6		45846
7	WASHER, SPL, M6 X 11.8MM X 1.6MM THK SST (BAG OF 10)	6		20921
8	BEARING/BRKT ASSEMBLY	2		43043
9	SCREW, HEX, 1/4-20 X 1/2 GR5 (BAG OF 10)	4		34518
10	WASHER, SPL, 1/4" (BAG OF 10)	4		45815
11	KIT, COUPLING, TYPE L	2		55481
12	KIT, SHAFT & CLUTCH ASSY	1		55482
13	KIT, SHAFT ASSY, RH	1		55483
14	KIT, SWITCH ASSY	1		55485
15	KIT, PLUNGER SWITCH	1		55484
16	SWITCH, LIMIT ROLLER, SPDT, 15A MAX	3		264104

**NOTE:** (REF) in QTY column is for Referenced Parts Only and are not sold as spare parts.

**NOTE:** \* Item or configuration not shown.

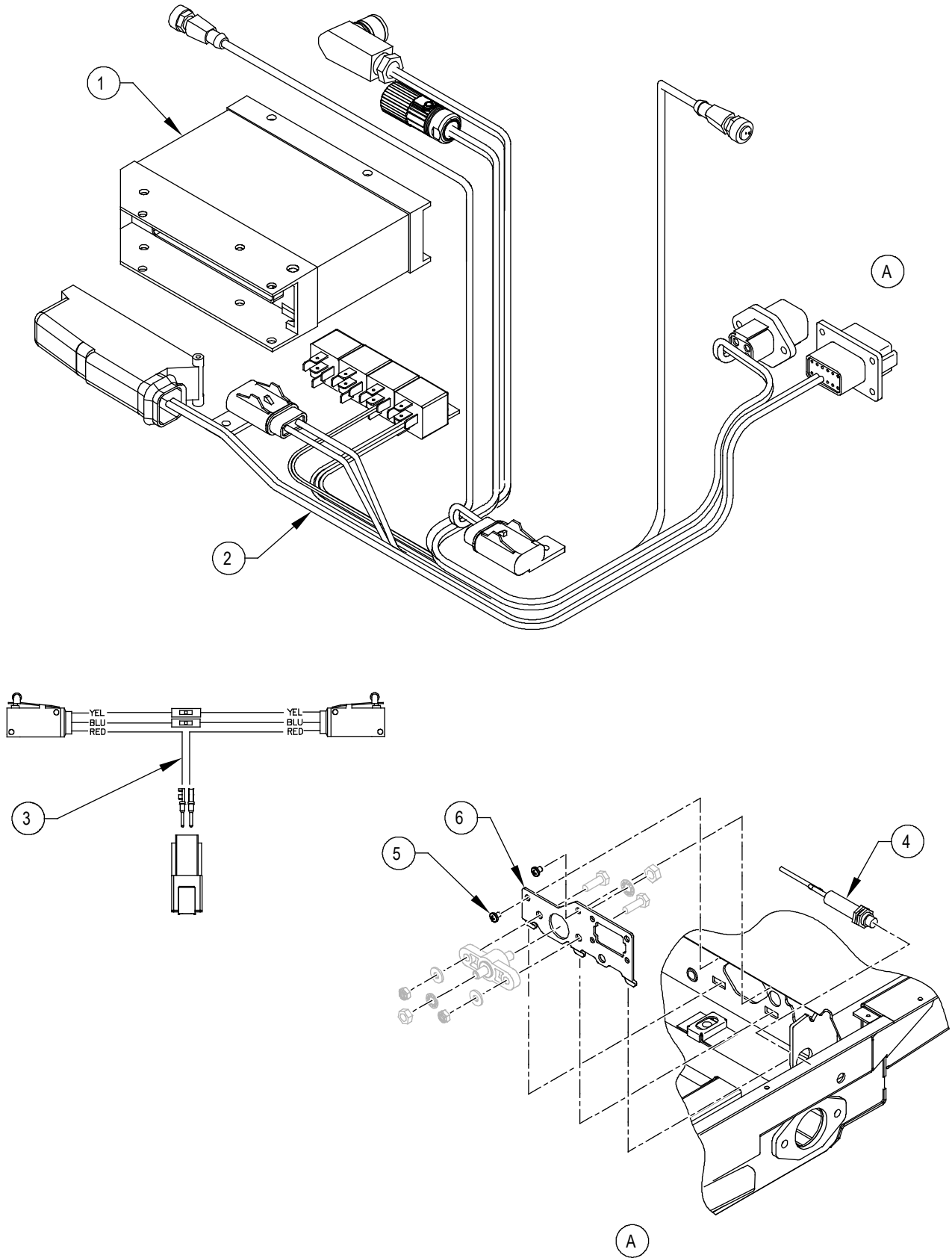

FIGURE 4-4: SSR-SERIES ELECTRICAL HARNESSES AND CONNECTORS

RSM0075200

FIGURE 4-4: SSR-SERIES ELECTRICAL HARNESSES AND CONNECTORS

FIG. ITEM	DESCRIPTION	QTY	CONFIG.	PART NO.
1	CONTROLLER	1		55205
2	HARNESS FOR STUDS, IFM CONTROLLER CR2500	1		55802
3	HARNESS, POSITION/DIRECTION	1		47888
4	INDUCTIVE PROXIMITY SENSOR	2		43951
5	SCREW, PHP, 10-24 x 1/4" SST (BAG OF 10)	2		25633
6	PLATE, ELECTRICAL	1		45390

**NOTE:** (REF) in QTY column is for Referenced Parts Only and are not sold as spare parts.

**NOTE:** \* Item or configuration not shown.

This page intentionally left blank.

APPENDIX 1

**TABLE 2-4: RICON SINGLE-SLOPE LOW-FLOOR-VEHICLE ACCESS 1:6 RAMP SPECIFICATIONS**

Power System .....	Electro-mechanical motor drive system
Power Requirements:	
Electric .....	24 VDC
Continuous Current .....	1.5 amps
Operating Current .....	5 amps
Rated Load Capacity .....	1000lbs. (453kg)
Ramp Weight .....	210 lbs. (95kg)

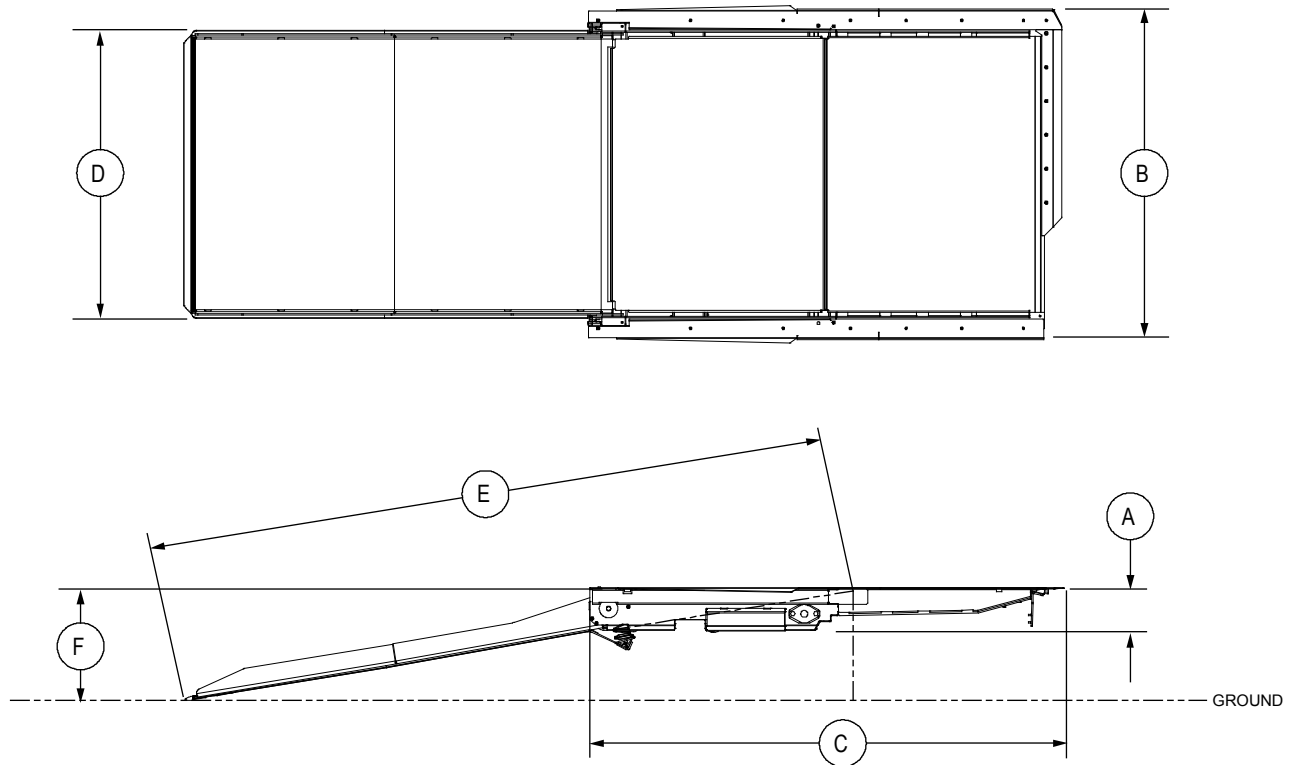

RSM0043600

**DIMENSIONS – Inches (mm)**

	A	B	C	D	E*	F**
MODEL	Ramp Frame Height	Ramp Trim Width	Ramp Trim Length	Useable Platform Width	Sloped Surface Length	Floor-To-Ground Travel
SSR-0	4.5 (114)	35.6 (904)	51.4 (1306)	30 (762)	71.9 (1826)	12 (305)

**END OF TABLE**

**NOTE:** Ramp may be configured to meet specific requirements.

**NOTE:** \* The effective ramp length takes into account the allowable vertical transitions. Actual length will be slightly shorter.

**NOTE:** \*\* In applications where the vertical height exceeds the specified amount, the length of the unit must be increased to maintain 1:6, rise over run relationship.



NOTES: