



**Ricon**®

**A Wabtec subsidiary**

*FoldOver*®

621SA-Series

Low Floor Bus Multi-Slope Ramp

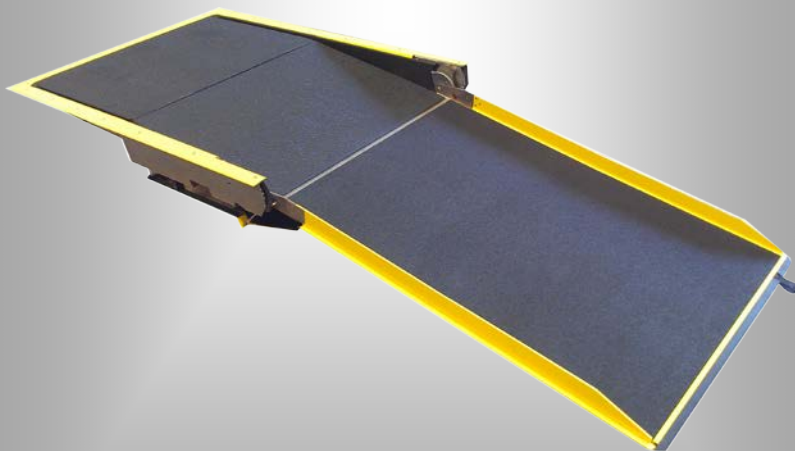

## Operator Manual

<https://ricondealer.wabtec.com>

02/23/14

32D6SA01.A

©2014 RICON CORPORATION

All Rights Reserved

[HOME](#)

U.S. Patent No. 13/063,384  
Other U.S. and foreign patents pending.  
Printed in the United States of America

This RICON product must be installed and serviced by a Ricon dealer or qualified service technician.

The operator must refer to this manual for operating instructions, then retain it for future reference.

<b>Customer Information</b>	
<b>Customer name</b>	
<b>Installing dealer</b>	
<b>Date installed</b>	
<b>Serial number</b>	

**REVISION RECORD**

REV	PAGES	DESCRIPTION OF CHANGE	ECR/ECO
32D6SA01. A		New Release.	

<u>Chapter:</u>	<u>Page</u>
<b>I. FOLDOVER MULTI-SLOPE RAMP INTRODUCTION .....</b>	<b>1-1</b>
A. RICON PRODUCT SUPPORT .....	1-1
B. PRODUCT TWO-YEAR WARRANTY .....	1-2
C. SHIPMENT INFORMATION .....	1-3
D. GENERAL SAFETY PRECAUTIONS.....	1-3
<b>II. FOLDOVER MULTI-SLOPE RAMP DESCRIPTION .....</b>	<b>2-1</b>
A. RAMP FEATURES .....	2-1
1. INTERLOCK SUPPORT .....	2-1
2. AUDIBLE ALERT .....	2-1
3. RAMP CONTROL PANEL .....	2-1
B. MAJOR COMPONENT DESCRIPTIONS.....	2-8
<b>III. FOLDOVER MULTI-SLOPE RAMP OPERATING INSTRUCTIONS .....</b>	<b>3-1</b>
A. SAFETY PRECAUTIONS.....	3-1
B. DAILY INSPECTION .....	3-2
C. RAMP OPERATION .....	3-2
1. OPERATING RAMP WITH CONTROL PANEL .....	3-3
2. OPERATING RAMP MANUALLY.....	3-5
<b>IV. FOLDOVER MULTI-SLOPE RAMP MAINTENANCE .....</b>	<b>4-1</b>
A. MAINTENANCE SCHEDULE .....	4-1
B. RAMP DECALS .....	4-2

This page intentionally left blank.

# I. FOLDOVER® 621SA-SERIES MULTI-SLOPE RAMP

This operator manual contains an introduction, product description, operating instructions, and a maintenance schedule for the Ricon 621SA-Series® Multi-Slope ramp when installed in transit vehicles

The unique, patent-pending, cam-based design of the Ricon FoldOver® 621SA-Series Multi-Slope ramp automatically adjusts to bus stop conditions to provide the least possible, continuous slope and the easiest access for passengers using wheeled mobility aids.

The Ricon FoldOver® 621SA-Series Multi-Slope ramp integrates a fully electric drive system with 1,000lb rated load capacity.

## A. PRODUCT SUPPORT

If there are questions about this manual, or you need copies, please contact Ricon Product Support at the following location:

Ricon Corporation  
 1135 Aviation Place  
 San Fernando, CA 91340.....(818) 267-3000  
 Outside (818) Area Code.....(800) 322-2884  
 Website .....www.riconcorp.com

Vapor Ricon Europe Ltd.  
 Meadow Lane  
 Loughborough, Leicestershire.....0044 (0) 1509 635 920  
 LE 1HS United Kingdom  
 Website .....www.riconuk.com

## B. PRODUCT WARRANTY

### RICON FOLDOVER® 621SA MULTI-SLOPE RAMP TWO-YEAR LIMITED WARRANTY

**Ricon Corporation (Ricon)** warrants to the original purchaser of this product that Ricon will repair or replace, at its option, any parts that fail because of defective material or workmanship as follows:

- Repair or replace parts for a period of two (2) years starting from the in-service date. Obtain a complete list of parts covered by this warranty from Ricon Product Support.
- Labor costs for specified parts replaced under this warranty for a period of two (2) years from date put into service. A Ricon rate schedule determines parts covered and labor allowed.

**If You Need to Return a Product:** Return this product to Ricon, following the Ricon RMA procedure. Please give as much advance notice as possible, and allow a reasonable amount of time for repair.

**This Warranty Does Not Cover:**

- Malfunction or damage to product parts caused by accident, misuse, lack of proper maintenance, neglect, improper adjustment, modification, alteration, the mechanical condition of the vehicle, road hazards, overloading, failure to follow operating instructions, or acts of nature (i.e., weather, lightning, flood).

**NOTE:** Ricon recommends that this product be inspected by a Ricon dealer or qualified service technician at least once every six months, or sooner if necessary. Required maintenance should be performed at that time.

#### WARNING

THIS PRODUCT HAS BEEN DESIGNED AND MANUFACTURED TO EXACT SPECIFICATIONS.  
ANY MODIFICATION OF THIS PRODUCT CAN BE HAZARDOUS

**This Warranty is Void If:**

- The product has been installed or maintained by someone other than a Ricon dealer or qualified service technician.
- The product has been modified or altered in any respect from its original design without written authorization by Ricon.

Ricon disclaims liability for any personal injury or property damage that results from operation of a Ricon product that has been modified from the original Ricon design. No person or company is authorized to change the design of this Ricon product without written authorization by Ricon.

Ricon's obligation under this warranty is exclusively limited to the repair or exchange of parts that fail within the applicable warranty period and the authorized labor to accomplish said repair.

Ricon assumes no responsibility for expenses or damages, including incidental or consequential damages. Some states do not allow the exclusion or limitation of incidental or consequential damages, so the above limitation or exclusion may not apply.

Important: The warranty registration card must be completed and returned to Ricon within 20 days after installation of this Ricon product for the warranty to be valid. The warranty is not transferable.

The warranty gives specific legal rights. There may be other rights that vary in each state.

### C. SHIPMENT INFORMATION

- When the product is received, unpack the product and check for freight damage. Claims for damage should be made to the freight carrier immediately.
- Be sure the installation kit contains all items listed on the kit packing list. Please report any missing items immediately to Ricon Product Support.
- The warranty and owner registration cards must be completed and returned to Ricon within 20 days to validate the warranty.

The sales or service personnel must review the Warranty and Operator Manual with the user to be certain that they understand how to safely operate the product and instruct the user to follow the operating instructions without exception.

### D. GENERAL SAFETY PRECAUTIONS

The following general safety precautions apply to the Ricon 621SA Multi-Slope ramp and must be followed during operation and maintenance:

- Read and thoroughly understand the operating instructions before attempting to operate the wheelchair ramp.
- Inspect product before each use. If unsafe conditions, unusual noises or movements, do not operate lift until the problem is corrected.
- Exercise caution when operating wheelchair lift to avoid injury, and be certain that hands, feet, legs or clothing are not in the path of product movement.
- Stand clear of doors and platform and keep others clear during operation.
- The wheelchair ramp requires regular periodic maintenance. A thorough inspection is recommended at least once every six months. The product should be maintained at the highest level of performance.



This page intentionally left blank.

## II. FOLDOVER® 621SA-SERIES RAMP DESCRIPTION

The Ricon FoldOver® 621SA-Series Multi-Slope ramp is installed in the entrance area of a transit vehicle and folds into the floor when not in use. The ramp is provided to assist passengers that use mobility-aid-equipment or passengers who have difficulty climbing steps. All 621SA-Series ramps have a 1000 lb (453kg) load limit.

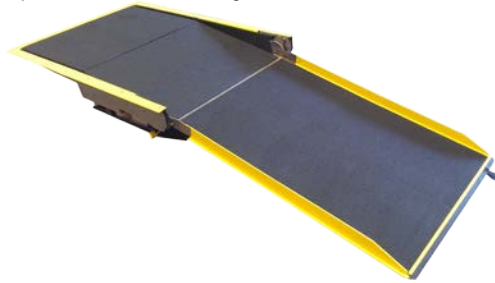

The FoldOver® 621SA-Series Multi-Slope ramp automatically adjusts to bus stop conditions to provide the least possible, continuous slope and the easiest access for passengers using wheelchair mobility aids. Unique ramp platform design provides high flexural rigidity while low torsional stiffness helps edge alignment with uneven curb or road surfaces.

### A. RAMP FEATURES

#### 1. INTERLOCK SUPPORT

The ramp electronic circuits can be connected to the vehicle interlock circuitry to keep the vehicle at a stop whenever the ramp is deployed. The ramp circuitry senses the position of the ramp (stowed or deployed) and makes this information available to the vehicle. Vehicle interlock circuits typically require that the following conditions be met before ramp operating power is made available to the ramp:

- Vehicle is safely parked and parking brake is ON.
- Transmission is in neutral.
- Vehicle doors adjacent to the ramp are open.

#### 2. AUDIBLE ALERT

**NOTE:** This feature is optional and may not have been connected during ramp installation. The ramp supports an audible alert device that sounds while the ramp is in motion.

#### 3. RAMP CONTROL PANEL

Refer to Figure 2-1. Ricon typically does not provide a control panel for the ramp. However, the ramp can be operated with one similar to that shown (the actual panel appearance will vary between transit authorities and vehicles). The control panel is normally installed in the driver area. It should have a power ON/OFF switch, a power on indicator light, and a spring-loaded, three position ramp control switch (center position is off). The ramp receives power from the vehicle when the interlock conditions are met and the control panel power switch is ON. The control panel can then be used to transmit deploy or stow signals to the ramp.

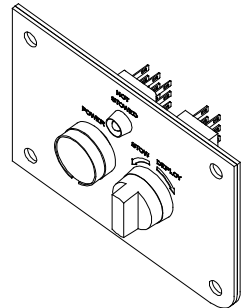

**FIGURE 2-1: TYPICAL CONTROL PANEL**

## B. MAJOR COMPONENT DESCRIPTIONS

Figure 2-2 shows major components of the Ricon FoldOver Multi-Slope ramp. A description of each component is provided in Table

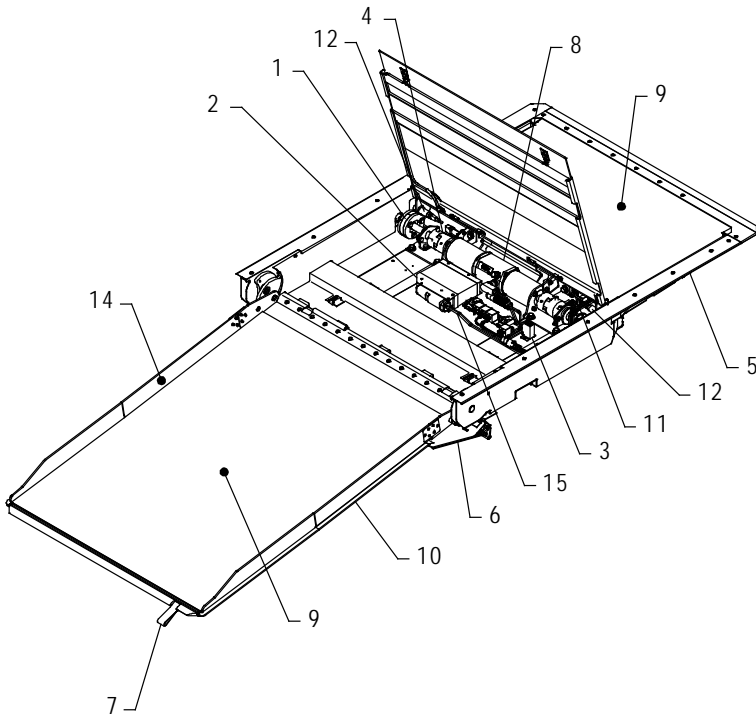

RSM006 1100

<b>TABLE 2-2: MAJOR RAMP COMPONENTS</b>	
<b>Item</b>	<b>Description</b>
Front, Rear, Left and Right	Reference point from outside the vehicle looking inward.
1	Adjustable Coupler - Use for adjustment and alignment of chain sprocket.
2	Controller – Translates electrical commands from bus control panel into signals that control ramp electro-mechanical components. Monitors ramp position and drives counter.
3	Counter – Counts each cycle.
4	Couplings - (Left & Right) Transmits rotary motion and attaches the drive motor shaft assemblies to the dual gearboxes.
5	Flange Kit - Perimeter trim pieces that are installed after the ramp has been installed in vehicle.
6	Front Cover - Front edge of ramp that opens and closes when platform is deployed or stowed.
7	Harness – Integrates conduits, relays, etc.
8	Lifting Strap - Use to assist in manual deploy or stow ramp.
9	Motor Drive System - Electro-mechanical motor-gearbox combination used to operate the ramp.
10	Non-Slip Surface – Flooring over which passengers traverse.
11	Platform Assembly - Area where passengers traverse over to enter and exit vehicle.
12	Positive Connection Block – Connection through which the ramp receives power from vehicle.
13	Proximity Sensors - Magnetic sensor devices that send signals to the ramp controller to indicate when the ramp is fully stowed (locks electromagnets) or deployed (unlocks electromagnets).

**TABLE 2-2: MAJOR RAMP COMPONENTS**

<b>Item</b>	<b>Description</b>
14	Ramp Tray Barrier - Left and Right side barrier of platform.
15	Slanted Floor Plate (Access Cover) - Portion of ramp that passenger traverses over to enter and exit vehicle which also provides access to electro-mechanical ramp components.

### III. MAINTENANCE

Read the operating instructions carefully before operating the Ricon FoldOver® 621SA-Series Multi-Slope Low-Floor Bus Ramp in a transit vehicle.

#### A. SAFETY PRECAUTIONS

Comply with these safety precautions:

- Perform the daily inspection described in **Table 3-1** (refer to **Section B** in this chapter).
- Refer to **Figure 3-1**. Do not deploy ramp when vehicle is parked on a sloping surface or a steeply crowned roadway. The increased ramp angle may pose a risk to ramp users.

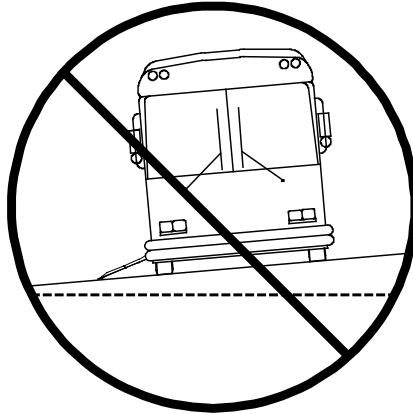

RSM0015100

**FIGURE 3- 1: RAMP MIDPOINT DURING DEPLOY**

- The ramp operator must supervise ramp while it is in use. Be certain passengers using the ramp board and exit the vehicle slowly and carefully.
- Check area around ramp for objects that might interfere with ramp operation.
- Inspect ramp before loading passengers. Do not use ramp if it exhibits unusual noise or erratic movement.
- Keep others at a safe distance when the ramp is deploying or stowing.
- Do not allow anyone (including operator) near moving ramp parts.
- Be certain mobility equipment fits ramp (outside width of mobility equipment must be less than ramp width).
- Passengers using mobility equipment (e.g., wheelchairs and scooters) must travel facing **forward** on ramp when they enter and exit; **it is never safe to travel backwards on ramp**.
- Ramp users must enter and exit vehicle one at a time (with or without mobility equipment). Do not exceed the ramp load capacity of 1000lbs (453kg).
- Caution ramp users to use care during wet conditions; shoes, wheels, brakes, etc. may slip on wet ramp surface.
- Do not allow anyone to play, sit, or rest on or near ramp.

- Supervise ramp while deployed. Retract ramp to its stowed position when not in use.
- Read and comply with warning labels affixed to ramp.

## B. DAILY INSPECTION

Check ramp daily following the Daily Inspection outlined in **Table 3-1**. Meet all inspection criteria before allowing passengers to use ramp.

<b>TABLE 3-1: DAILY INSPECTION</b>	
<b>Inspection Points</b>	<b>Check</b>
Ramp control panel (typical)	<ul style="list-style-type: none"> <li>▪ Power ON/OFF switch operates correctly.</li> <li>▪ Power On indicator illuminates when Power ON/OFF switch is ON.</li> <li>▪ DEPLOY and STOW switches operate correctly.</li> </ul>
Ramp and surrounding area	<ul style="list-style-type: none"> <li>▪ No indication of unusual noise or erratic movement when ramp is deploying or stowing.</li> <li>▪ Vestibule area must be clear of loose objects and must be free of debris.</li> </ul>
Ramp non-slip surface	<ul style="list-style-type: none"> <li>▪ Surface must be clean, and free of slippery or sticky substances that could compromise user safety.</li> </ul>

## C. RAMP OPERATION



### **WARNING!**

IMPROPER USE OF RAMP CAN RESULT IN PERSONAL INJURY. OPERATOR MUST READ AND FOLLOW THE OPERATING INSTRUCTIONS IN THIS MANUAL. ADDITIONAL COPIES OF THIS MANUAL ARE AVAILABLE FROM:

**RICON CORPORATION**  
**1135 AVIATION PLACE**  
**SAN FERNANDO, CA 91340**  
**(818) 267-3000 or (800) 322-2884 (in US)**

- CHECK RAMP AND RELATED COMPONENTS BEFORE USE FOR PROPER FUNCTION, REQUIRED MAINTENANCE, OR DAMAGE. DO NOT USE RAMP IF A PROBLEM EXISTS, AND SEEK A RICON DEALER OR QUALIFIED SERVICE TECHNICIAN FOR INSPECTION.
- DO NOT EXCEED RAMP LOAD CAPACITY OF 1000 POUNDS (453 KILOGRAMS).
- THE RAMP IS DESIGNED FOR PERSONS USING MOBILITY-AID EQUIPMENT OR FOR PASSENGERS THAT CANNOT CLIMB STEPS.

RICON CORPORATION DISCLAIMS LIABILITY FOR DAMAGE OR PERSONAL INJURY RESULTING FROM IMPROPER INSTALLATION, MODIFICATION TO THE RAMP OR OTHER COMPONENTS, LACK OF MAINTENANCE OR REPAIR, NEGLIGENCE, ABUSE OR FAILURE TO FOLLOW THE OPERATING INSTRUCTIONS.

- Perform the daily safety check described in **Table 3-1** before putting vehicle into service. If a problem exists, do not use ramp; seek a Ricon dealer or qualified service technician for repair.
- Comply with the Safety Precautions at the beginning of this chapter.
- Control of the vehicle transmission and brakes is removed while ramp is deployed; control is restored when ramp is fully stowed.

**1. OPERATING RAMP WITH A CONTROL PANEL**

**a. Prepare Vehicle**

- 1.) Park vehicle where deployment and use of ramp is safe.
- 2.) Apply parking brake, place transmission in neutral and open door adjacent to ramp.

**NOTE:** Ramp can only be deployed when the parking brake is set, the transmission is in neutral, and the vehicle door adjacent to the ramp is open.

- 3.) When deploying to street level, kneel vehicle prior to deploying ramp. When deploying to standard curb, kneeling is not required.
- 4.) Caution people inside and outside to clear the area because the ramp is about to deploy.

**b. Deploy Ramp**

 <b>WARNING!</b>
<b>MAKE SURE PEOPLE ARE A SAFE DISTANCE FROM RAMP AREA BEFORE OPERATING.</b>

- 1) Apply power to ramp by activating power switch on ramp control panel; Power On indicator should illuminate.
- 2) Refer to **Figure 3-2**. Turn and hold the DEPLOY switch until ramp reaches its level position and the FULLY DEPLOYED light turns on. Motor drive system will stop automatically when ramp reaches its level position.

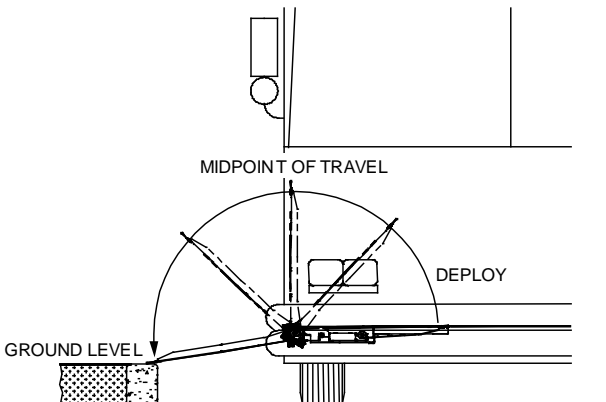

RSM0015200

**FIGURE 3- 2: RAMP DURING DEPLOY**



- NOTE:** Pressing the DEPLOY button will have no further affect after motor drive system cutoff.
- NOTE:** The vehicle audible alert will sound (if connected) while ramp is in motion.
- NOTE:** You can reverse the direction of ramp movement at any time by turning switch to the STOW position.
- NOTE:** Ramp users are required to enter and exit vehicle **one at a time**. Passengers using mobility equipment (e.g., wheelchairs and scooters) should **travel facing forward** when on ramp.

### c. Stow Ramp



## WARNING!

MAKE SURE PEOPLE ARE A SAFE DISTANCE FROM RAMP AREA BEFORE OPERATING.

- 1) Refer to **Figure 3-3**. Turn and hold the STOW button until ramp is fully stowed and the NOT FULLY STOWED light turns off. Motor drive system will shut off.

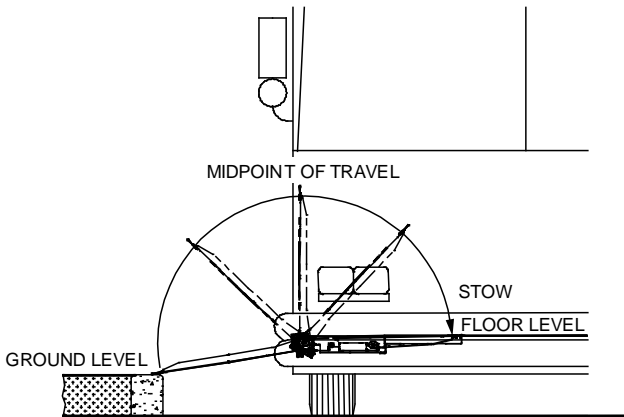

RSM0015201

**FIGURE 3- 3: RAMP DURING STOW**

- NOTE:** The audible alert sounds, if connected, while ramp is in motion.
- NOTE:** You can reverse the direction of ramp movement at any time by turning the DEPLOY position.
- NOTE:** Motor works as brake after ramp has passed 90°.
- NOTE:** Ramp users are required to enter and exit vehicle **one at a time**. Passengers using mobility equipment (e.g., wheelchairs and scooters) should **travel facing forward** when on ramp.
- 2) Close vehicle door.
- NOTE:** Be certain ramp is fully stowed before you close door or operate vehicle.

## 2. MANUAL OPERATION

### a. Prepare Vehicle

 <b>WARNING!</b>
COMPLY WITH SAFETY PRECAUTIONS AT BEGINNING OF THIS CHAPTER.

- 1.) Park vehicle in a safe, level area. Lower vehicle, if this function is available and working.
- 2.) Apply parking brake.
- 3.) Put transmission in neutral, and open door adjacent to ramp.

### b. Deploy Ramp

- 1) Turn power to ramp OFF. Energized ramp will not allow for manual deployment.
- 2) Grasp lifting strap, located on ramp platform, then pull to deploy platform from stowed position.

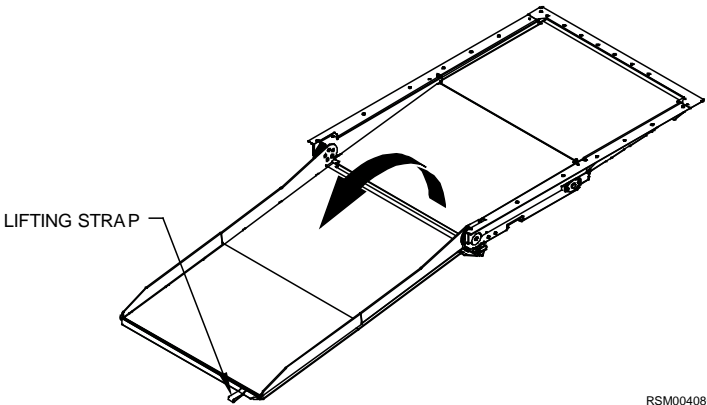
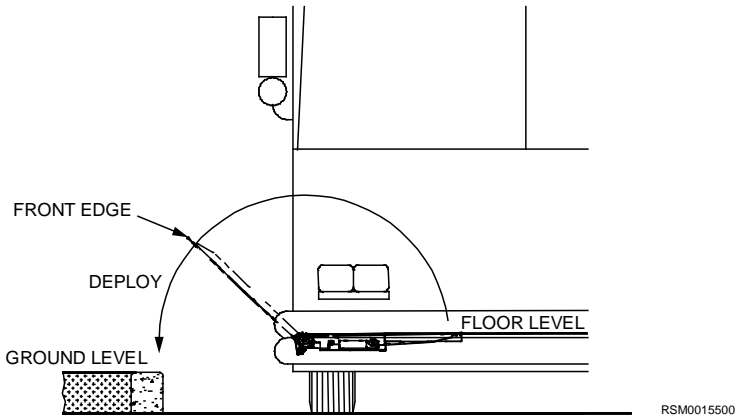

FIGURE 3- 4: MANUAL DEPLOY

- 3) Lift ramp platform sufficiently to obtain a handhold on front edge of ramp.

 <b>WARNING!</b>
KEEP YOUR BACK VERTICAL AND LEGS TOGETHER WHEN LIFTING RAMP.

- 4) Grip front edge of ramp with both hands, and begin to slowly unfold from its stowed position.



**FIGURE 3- 5: RAMP DURING MANUAL DEPLOY**

- 5) Unload passengers. Passengers using mobility-aid equipment (e.g., wheelchairs and scooters) must **travel forward** when on ramp.

### c. Stow Ramp



#### **WARNING!**

COMPLY WITH SAFETY PRECAUTIONS AT BEGINNING OF THIS CHAPTER.

- 1) Grasp lifting strap at front edge of ramp (refer to **Figure 3-4**).



#### **WARNING!**

AVOID PINCHING YOUR FINGERS WHEN MANUALLY LIFTING RAMP. KEEP YOUR BACK VERTICAL AND LEGS TOGETHER WHEN LIFTING RAMP.

- 2) Lift ramp slightly to obtain a handhold on front edge of ramp.



#### **CAUTION!**

Do not use **excessive** force when lifting ramp because damage to the ramp components could result.

- 3) Lift ramp and begin to push it toward the stowed position.

**NOTE:** Be certain ramp is fully stowed before closing door or operating vehicle.

### III. MAINTENANCE

This chapter contains regular maintenance and inspection of the Ricon FoldOver® 621SA-Series Multi-slope Low-Floor Bus Ramp provides optimum performance and reduces the need for repairs. Maintain the ramp as directed in **Table 4-1**, adhering to the cautions noted below. Perform ramp maintenance more frequently during heavy use (more than 20 cycles per day). Refer to the Ricon FoldOver 621SA-Series Multi-Slope Low-Floor Bus Ramp Service Manual 32D62102 for complete maintenance and troubleshooting information

#### A. ADDITIONAL MAINTENANCE INFORMATION

Additional maintenance information is available in the RICON FoldOver® 621SA service manual, part number 32D6SA02. This manual is available from Ricon in printed hard copy, or at the Ricon website in PDF format. The website is located at [www.RiconCorp.com](http://www.RiconCorp.com). At the website, click on “Technical Documents”, “I agree”, and then “Service Manuals”.

 <b>WARNING</b>
<p>THIS RICON PRODUCT IS HIGHLY SPECIALIZED. MAINTENANCE AND REPAIRS MUST BE PERFORMED BY A RICON DEALER OR QUALIFIED SERVICE TECHNICIAN USING RICON REPLACEMENT PARTS. MODIFYING OR FAILING TO PROPERLY MAINTAIN THIS PRODUCT WILL VOID THE WARRANTY, AND MAY RESULT IN UNSAFE OPERATING CONDITIONS.</p>

#### B. CLEANING

Regular cleaning with mild soap (i.e. liquid hand soap or car wash liquid) and drying thoroughly will protect lift painted surfaces. Cleaning is especially important in areas where roads are salted in winter. Make sure that lift pivot points are clean and dry prior to lubrication.

#### C. MAINTENANCE SCHEDULE

Refer to cycle counter located on rear side of hydraulic power unit. Under normal operating conditions, maintenance inspections are required at the frequencies listed in **Table 4-1**. Ten cycles is considered an average number of cycles for one day.

<b>TABLE 4-1: MAINTENANCE SCHEDULE</b>	
<b>Inspection Point</b>	<b>Action</b>
<b>– 6,000 MILE INSPECTION –</b>	
Electrical system	<ul style="list-style-type: none"> <li>• Check all cables and fittings; tighten or replace as necessary.</li> <li>• Check chain spring assembly for wear or missing parts.</li> </ul> <p><b>NOTE:</b> Refer to Service Manual for details.</p>
Cover Fasteners	Check all threaded fasteners for looseness, and tighten as necessary.
Ramp interior (for debris)	Check ramp interior area and remove accumulated dirt and debris.
(continued)	

TABLE 4-1: MAINTENANCE SCHEDULE	
Inspection Point	Action
Non-slip surfaces	Check for excessive wear, as well as loose edges; replace as necessary.
Decals	Check for illegibility or looseness; replace as necessary.
<b>– 12,000 MILE INSPECTION –</b>	
Wiring harnesses	<ul style="list-style-type: none"> <li>▪ Check wiring insulation for heavy abrasion or cuts; replace as necessary.</li> <li>▪ Check connectors for looseness. Secure as necessary.</li> </ul> <p><b>NOTE:</b> Harnesses are routed below ramp floor and between ramp assembly and vehicle.</p>
Cover Fasteners	Check all threaded fasteners for looseness, and retighten as necessary.
<b>– 24,000 MILE INSPECTION –</b>	
CAM Shaft Assembly	Grease or oil to lubricate parts is NOT recommended. Keep components clean and free of debris
END OF TABLE	

**D. RAMP DECALS**

Refer to **Figure 4-1**. Inspect decals at intervals in **Table 4-1**. Inspect for chipping, peeling, fading, and illegibility. Replace a decal by ordering the part number shown in figure, and applying it where shown. Surface must be clean and free of debris before applying decal.

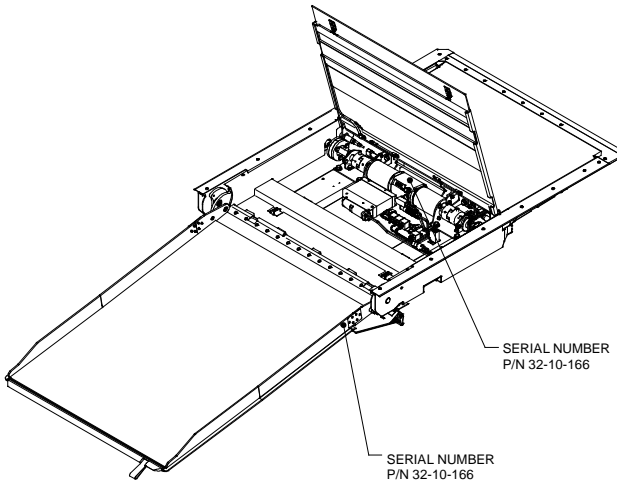

RSM0061200

**FIGURE 4-1: DECAL LOCATIONS**