

RICON®

INNOVATION IN MOBILITY

Innovator™ Personal Use Wheelchair Lift

PRINT ENTIRE MANUAL (2888K)

TABLE OF CONTENTS

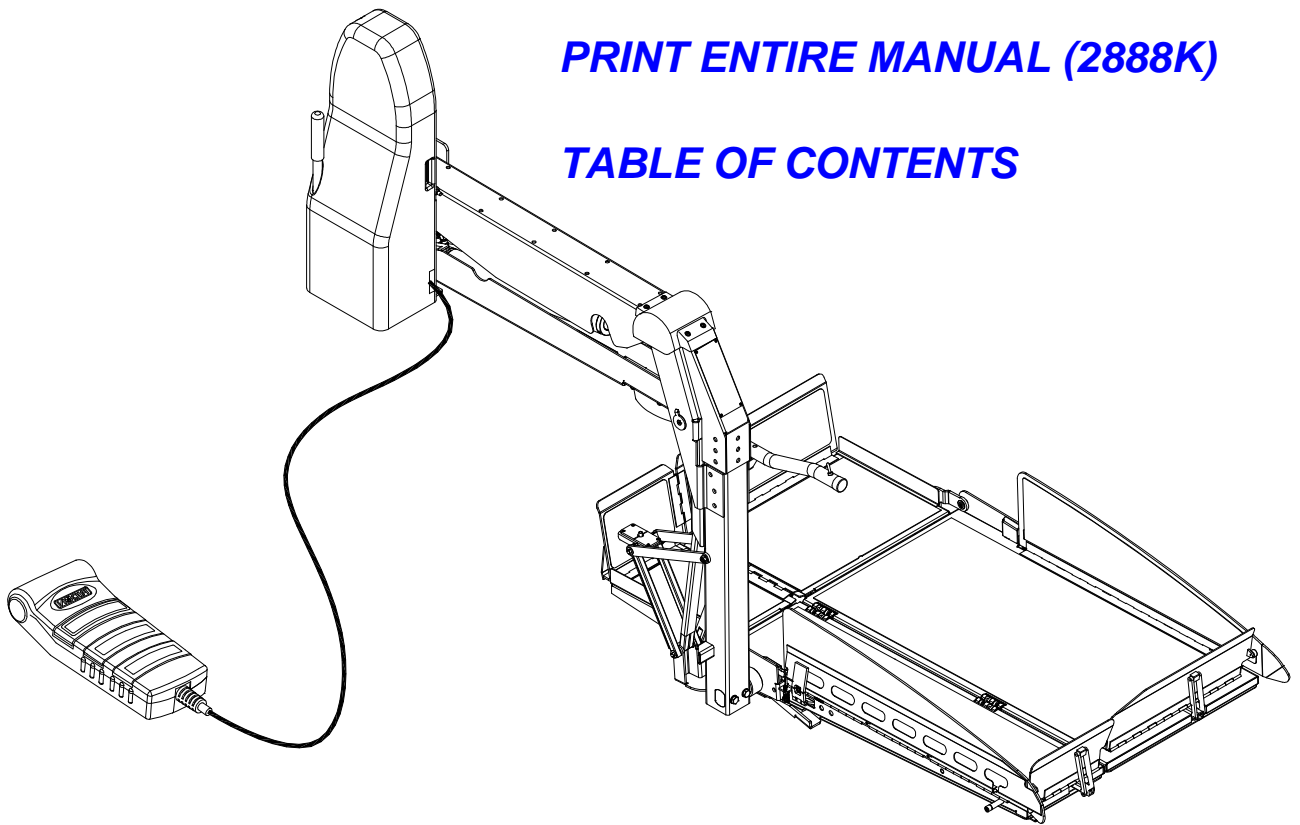

Service Manual

This Ricon service manual is for use by qualified service technicians, and is not intended for use by non-professionals (do-it-yourselfers). The manual provides essential instructions and reference information, which supports qualified technicians in the correct installation and maintenance of Ricon products.

Qualified service technicians have the training and knowledge to perform maintenance work properly and safely. For the location of a Ricon authorized service technician in your area, call Ricon Product Support at 1-800-322-2884.

Customer Name:	_____
Installing Dealer:	_____
Date Installed:	_____
Serial Number:	_____

REVISION RECORD

REV	DATE	PAGES	DESCRIPTION OF CHANGE	ECO
32DFL02. E	10/13/03	3-1	Edited Table 3-1. "Maintenance Checklist".	5191 5123 5067
		3-3	Edited Table 3-2, "Troubleshooting Guide".	
		3-7	Edited section C.2 "Electrical System Diagnostic Display".	
		3-10	Added Table 3-4 "Numerical Display Descriptions".	
		3-11	Edited Table 3-5 "Display Number Descriptions for Deploy Motion".	
		3-12	Edited Table 3-6 "Display Number Descriptions for Down Motion".	
		3-13	Edited Table 3-7 "Display Number Descriptions for Up Motion".	
		3-14	Edited Table 3-8 "Display Number Descriptions for Stow Motion".	
		4-5	Changed p/n for the following items: 2- from 21205 to 29080; 10- from 19066 to 29297; 14- V2-ES-93 to offering it in kit V2-ES-61. Added item 20- V2-ES-82.	
		4-8/4-9	Changed p/n for item 13- from 29241 to 25550. Callouts for Items 12-15 were missing from the drawing. Removed item 16-29051 from list.	
		4-15	Switched item 1 with item 2. Switched item 4 with item 13.	
		4-16	Changed items 8 and 15.	
		4-17	Switched item 10 with item 11.	
		4-19	Changed item 8- from 24581 to 29745.	
		4-21	Changed item 5- from 29216 to 29747.	
4-28 & 4-29	Added figure and parts list for pump assembly.			
		4-2	Changed part number for item 2, from 21205 to PM212000008.	5191 5198
END OF TABLE				

TABLE OF CONTENTS

<i>Chapter</i>	<i>Page</i>
I. INTRODUCTION	1-1
A. RICON SERVICE SUPPORT	1-1
B. RICON ONE-YEAR WARRANTY	1-1
C. SHIPMENT INFORMATION	1-3
D. GENERAL SAFETY PRECAUTIONS	1-3
E. INNOVATOR COMPONENT TERMS	1-4
II. INSTALLATION	2-1
A. MECHANICAL INSTALLATION	2-2
1. VEHICLE PREPARATION	2-2
2. LIFT INSTALLATION NOTES	2-2
3. LIFT INSTALLATION.....	2-2
B. ELECTRICAL INSTALLATION	2-4
1. CONTROL INTERFACE AND DOOR OPERATOR	2-4
2. MAIN CIRCUIT BREAKER	2-4
3. MAIN POWER CABLE	2-4
4. LIFT ELECTRICAL GROUNDING.....	2-5
C. FINAL ADJUSTMENTS	2-6
1. PLATFORM LIMIT SWITCHES.....	2-6
2. ANTI-STOW PRESSURE SWITCH	2-7
D. VERIFY INSTALLATION	2-8
1. LOAD TEST	2-8
2. DECAL INSPECTION	2-8
3. MISCELLANEOUS	2-8
E. CUSTOMER ORIENTATION	2-8
III. MAINTENANCE AND TROUBLESHOOTING	3-1
A. CLEANING	3-1
B. MAINTENANCE CHECKLIST	3-1
C. TROUBLESHOOTING	3-2
1. TROUBLESHOOTING GUIDE	3-2
2. ELECTRICAL SYSTEM DIAGNOSTICS DISPLAY	3-7
D. HYDRAULIC SYSTEM	3-13
E. LIFT ELECTRICAL WIRING	3-14
1. DIAGRAM LEGENDS	3-14
2. ELECTRICAL CONNECTORS.....	3-15
3. WIRING DIAGRAM LABELS.....	3-15
4. WIRING DIAGRAMS.....	3-16
IV. SPARE PARTS	4-1
FIGURE 4-1: DECAL PART NUMBERS AND LOCATIONS	4-2
FIGURE 4-2: TOWER ASSEMBLY	4-4
FIGURE 4-3: TOWER ELECTRICAL CABLES	4-6
FIGURE 4-4: TRAVELING FRAME ASSEMBLY	4-8
FIGURE 4-5: PLATFORM LEVELING ASSEMBLY	4-10
FIGURE 4-6: REAR PLATFORM ASSEMBLY	4-12
FIGURE 4-7: FRONT PLATFORM ASSEMBLY SHEET-1	4-14
FIGURE 4-8: FRONT PLATFORM ASSEMBLY SHEET-2	4-16

FIGURE 4-9: FRONT PLATFORM ASSEMBLY SHEET-3..... 4-18
FIGURE 4-10: FRONT PLATFORM ASSEMBLY SHEET-4..... 4-20
FIGURE 4-11: PLATFORM WRAP MOTOR ASSEMBLY 4-22
FIGURE 4-12: ROLLSTOP AND SIDE BARRIER MOTOR ASSEMBLY..... 4-24
FIGURE 4-13: BRIDGEPLATE MOTOR ASSEMBLY 4-26
FIGURE 4-14: PUMP ASSEMBLY 4-28

APPENDIX 1 4-30

-GO TO NEXT CHAPTER-