

THE RICON® TITANIUM™ LINE

THE TITANIUM™ LINE S-SERIES® AND K-SERIES® WHEELCHAIR LIFTS



The heavy-duty Titanium Line of S-Series and K-Series wheelchair lifts feature the industry-leading Ricon Safety Zone and advanced engineering that delivers the most reliable, high capacity, low-maintenance performance for all paratransit applications.

- Full 3-year warranty
- True 1,000lb capacity
- Dura-Touch™ hand control pendant
- Dual twist-n-lock pendant connection points
- EZ-Roll™ platform to vehicle transition
- LED handrail lights
- Rollerized outboard rollstop



NEW TITANIUM™ LINE S-SERIES® AND K-SERIES® LIFTS DELIVER BEST-IN-CLASS PERFORMANCE AND VALUE

Innovation and Leadership Since 1971

Millions of people in over 30 countries worldwide rely on Ricon wheelchair lifts every day. Since 1971 we have dedicated our business to the design and manufacture of innovative commercial access products to meet the growing demands of the global passenger transportation industry.

Today, as a Wabtec company and operating from our modern facility in the Los Angeles area, Ricon Corporation is the largest manufacturer of its kind in the world.



Ricon was the first North American wheelchair lift manufacturer to achieve ISO 9001:2000 certification and all Ricon paratransit product designs are tested to meet or exceed the most rigorous elements of FMVSS 403/404, 49 CFR, part 38 (ADA), CSA D409, and the California Vehicle Code (CA Title 13).

ADVANCED RICON TITANIUM DESIGN FEATURES BENEFIT THE OEM INSTALLER, THE GROWING COMMUNITY OF MOBILITY-CHALLENGED PASSENGERS, DRIVER OPERATORS AND AGENCIES.

The new Titanium Line of S-Series and K-Series wheelchair lifts provide unparalleled performance and lasting value. Ricon lifts set the industry standard for secure access, reliability and ease of use, whether you are transporting passengers across town or children to school. Heavy-duty Titanium Line designs comply with all applicable ADA and FMVSS regulations and include many exclusive best-in-class features.

- FMVSS and ADA compliant
- Full 3-year warranty
- True 1,000lb capacity
- Dura-Touch™ hand control pendant
- Dual twist-n-lock pendant connection points
- EZ-Roll™ platform to vehicle transition
- LED handrail lights
- Rollerized outboard rollstop
- Lubrication-free bearings and pins
- Patented Sto-Loc™ technology

MADE IN THE U.S.A.

EXCLUSIVE DURA-TOUCH CONTROL PENDANT – Tough and versatile new pendant features shock-resistant polypropylene case with bumper edges, water-resistant buttons and heavy-duty coiled cord. Dual pendant interfaces enable mounting, without modification, on either side of the lift.



QUICK-RELEASE PUMP COVER – Provides easy access to internal components without the need for tools. Adjustments and manual operation may be performed with the pump cover in place.



EZ-ROLL™ INBOARD ROLLSTOP – New EZ-Roll™ inner barrier lays completely flat for smooth platform to vehicle and vehicle to platform transitions.



K-Series Lift

The Ricon K-Series®, KlearVue™ heavy-duty reinforced platform automatically folds to provide an unobstructed view by the passenger and driver.

FEATURING THE INDUSTRY-LEADING RICON SAFETY ZONE,
SPACE-SAVING FOOTPRINT AND USER-FRIENDLY DESIGN



LOW PROFILE THRESHOLD WARNING BEACON – Provides 360° visibility of threshold warning signal.



HYDRAULIC CYLINDERS WITH ENGINEERED POLYMER SEALING TECHNOLOGY – And integral, easy-to-reach flow control valves eliminate the need to remove hose or fitting providing years of worry-free operation. Melonite® coated pins with Teflon® coated bearings require no lubrication.



THE RICON SAFETY ZONE

Surrounds passenger with safety features for optimal security during lift operation.

CYCLE COUNTER – Tracks usage for service and maintenance reference.



S-Series Lift

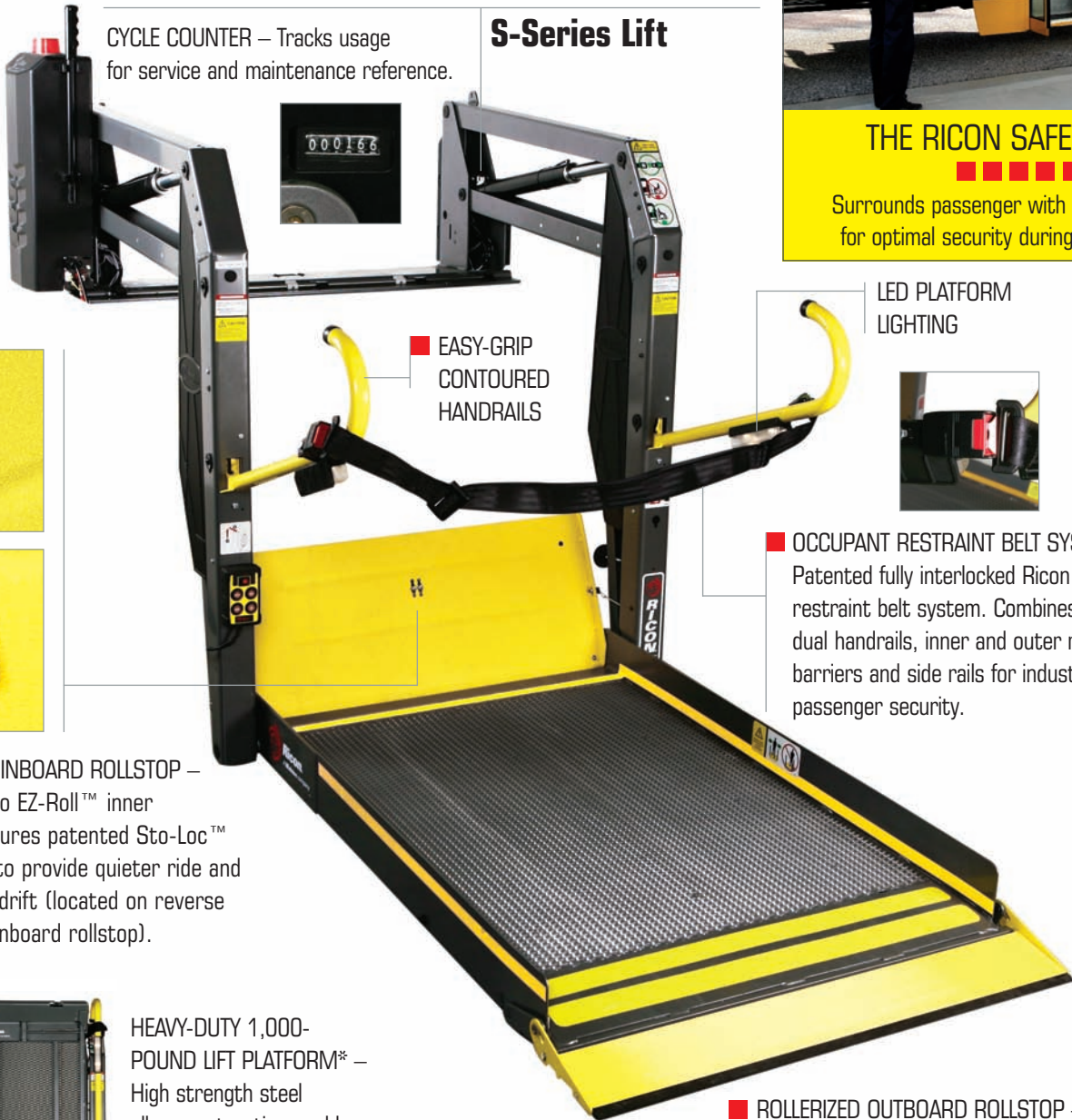

LED PLATFORM LIGHTING



OCCUPANT RESTRAINT BELT SYSTEM – Patented fully interlocked Ricon occupant restraint belt system. Combines with dual handrails, inner and outer rollstop barriers and side rails for industry-leading passenger security.

EASY-GRIP CONTOURED HANDRAILS

AUTOMATIC INBOARD ROLLSTOP – In addition to EZ-Roll™ inner barrier, features patented Sto-Loc™ technology to provide quieter ride and prevent lift drift (located on reverse side of the inboard rollstop).



HEAVY-DUTY 1,000-POUND LIFT PLATFORM* – High strength steel alloy construction enables a true, 1,000lb lifting capacity. Durable, titanium gray polyester powder coat finish complements most vehicle interiors.



ROLLERIZED OUTBOARD ROLLSTOP – Advanced design features one-piece extruded aluminum barrier with quiet-touch rubber tip and solid mechanical actuator assisted by rollers for smooth operation on widest range of surfaces.

* Requires vehicle specific application engineering – not intended for retrofit.

FOR MORE INFORMATION, CALL 800-322-2884 OR VISIT US ONLINE AT RICONCORP.COM



THE TITANIUM™ LINE OF S-SERIES® AND K-SERIES® WHEELCHAIR LIFTS

S-SERIES® LIFT: Models: S2005-S5510

Rated Load CapacityUp to 1,000 lbs / 454 kg*
 Lift WeightApprox. 400 - 425 lbs / 181 -193 kg
 PowerElectro-Hydraulic
 Hydraulic Cylinders(2) each, 1.5" Power-Up / Gravity Down
 Motor Rating @ 12V DC65 amp avg. / cycle 1750 psi
 Manual Backup (up)Hand Pump
 Manual Backup (down)Pressure Release Valve

* Requires vehicle specific application engineering – not intended for retrofit.

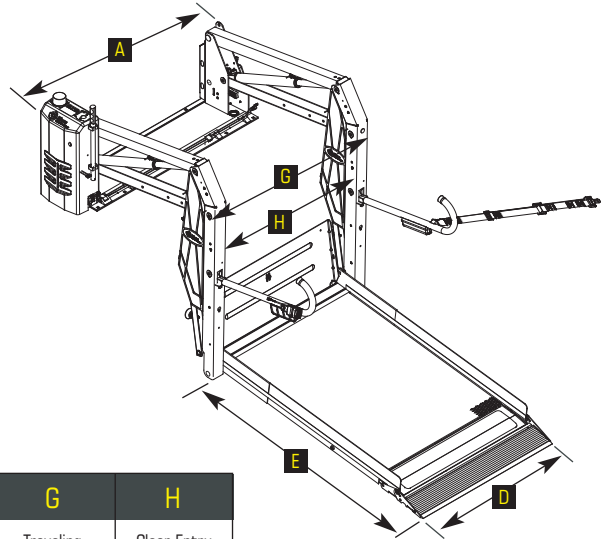

Dimensions Inches/Millimeters

MODEL	A	B	C	D	E	F	G	H
	Stationary Frame Width	Height (folded)	Installation Depth (folded)	Usable Platform Width	Usable Platform Length	Floor-to-Ground Travel	Traveling Frame Width	Clear Entry Width
S2005	47/1194	54/1372	14/356	32/813	51/1295	42/1067	40.5/1029	32/813
S2010	49/1245	57/1448	14/356	34/864	54/1372	42/1067	42.5/1080	34/864
S5505	47/1194	57.5/1461	15/381	32/813	51/1295	51/1295	41/1041	32/813
S5510	49/1245	57.5/1461	15/381	34/864	54/1372	51/1295	43/1092	34/864

- Audible/Visual Threshold Warning Display
- Optical Threshold Warning Sensors
- Inboard Rollstop Interlock
- Automatic Inner Barrier Rollstop
- Two-Tiered Outer Barrier
- Onboard LED Platform Lighting
- Cycle Counter

K-SERIES® LIFT: Models: K2005-K5510

Rated Load CapacityUp to 1,000 lbs / 454 kg*
 Lift WeightApprox. 400-425 lbs / 181 -193 kg
 PowerElectro-Hydraulic
 Hydraulic Cylinders(2) each, 1.5" Power-Up / Gravity Down
 Motor Rating @ 12V DC65 amp avg. / cycle 1750 psi
 Manual Backup (up)Hand Pump
 Manual Backup (down)Pressure Release Valve

* Requires vehicle specific application engineering – not intended for retrofit.

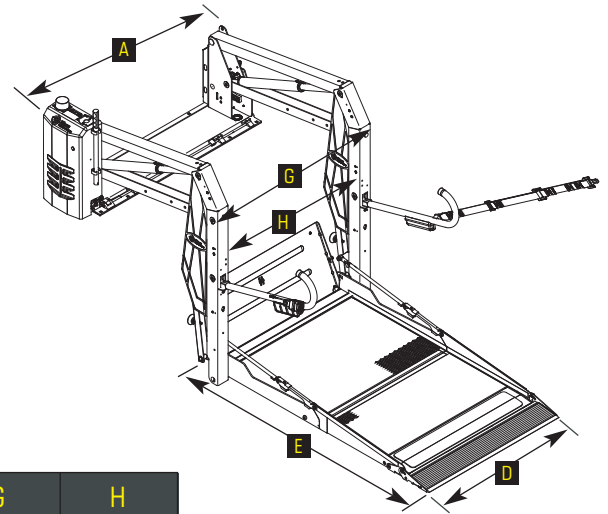

Dimensions Inches/Millimeters

MODEL	A	B	C	D	E	F	G	H
	Stationary Frame Width	Height (folded)	Installation Depth (folded)	Usable Platform Width	Usable Platform Length	Floor-to-Ground Travel	Traveling Frame Width	Clear Entry Width
K2005	47/1194	54/1372	16.5/419	31/787	51/1295	37/940	40.5/1029	31.25/794
K2010	49/1245	54/1372	16.5/419	33/838	54/1372	37/940	42.5/1080	33.75/857
K5505	47/1194	57.5/1461	17.5/445	31/787	51/1295	48/1219	41/1041	31.25/794
K5510	49/1245	57.5/1461	17.5/445	33/838	54/1372	48/1219	43/1092	33.75/857

- Audible/Visual Threshold Warning Display
- Optical Threshold Warning Sensor
- Inboard Rollstop Interlock
- Automatic Inboard Rollstop
- Two-Tiered Outer Barrier
- Onboard LED Platform Lighting
- Cycle Counter

CALL TOLL-FREE: 1-800-322-2884

RICONCORP.COM

RICON CORPORATION 7900 Nelson Road Panorama City, CA 91402

Copyright 2012 Ricon Corporation. Ricon, Titanium, S-Series, K-Series, KlearVue, Sto-Loc and EZ-Roll are trademarks of Ricon Corporation. All Rights Reserved. Ricon Corp. reserves the right to discontinue models or options at any time or change specifications, materials, equipment, or pricing without notice and without incurring obligation.

PN 32SL629 (05 12 1M)

