



Ricon®

A Wabtec company

Slide-Away® Export Use Wheelchair and Standee Lift

-PRINT-

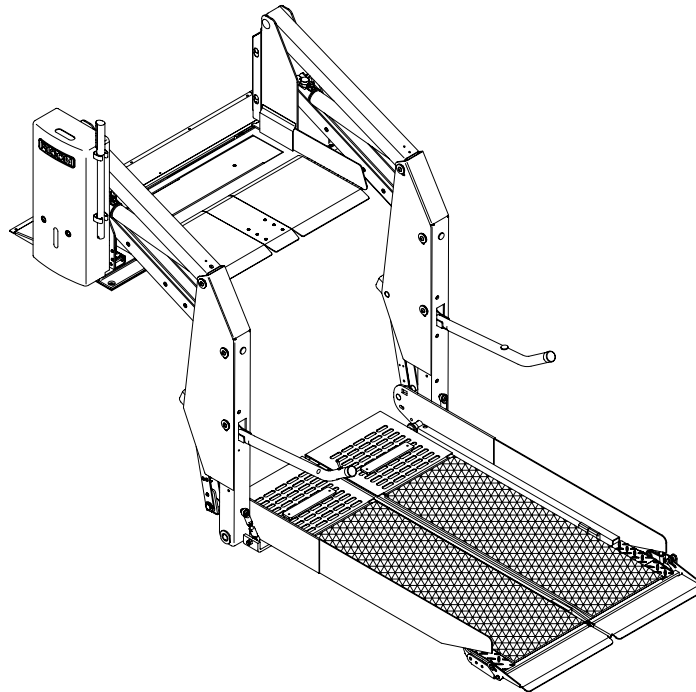

Service Manual

-HOME-

This Ricon service manual is for use by qualified service technicians, and is not intended for use by non-professionals. The manual provides essential instructions and reference information, which supports qualified technicians in the correct installation and maintenance of Ricon products.

Qualified service technicians have the training and knowledge to perform maintenance work properly and safely. For the location of a Ricon authorized dealer or qualified service technician in your area, call Ricon Product Support at 1-800-322-2884.

Customer Name: _____

Installing Dealer: _____

Date Installed: _____

Serial Number: _____

REVISION RECORD

REV	PAGES	DESCRIPTION OF CHANGE	ECR/ECO
32DSW04. D.1 02/24/11	Cvr	Update to trademark symbol.	550064
	1-1	Update to weight specification.	
	1-2	Update to warranty text.	
	2-2, 2-13	Update to weight specification.	
	3-1, 3-3, 3-4, 3-16	Update to caution note text.	
	4-1	Update to trademark symbol.	

TABLE OF CONTENTS

<i>Chapter</i>	<i>Page</i>
I. INTRODUCTION	1-1
A. WARRANTY INFORMATION	1-2
B. SHIPMENT INFORMATION	1-3
C. GENERAL SAFETY PRECAUTIONS	1-3
D. PRIVATE USE MAJOR LIFT COMPONENTS	1-4
II. INSTALLATION	2-1
A. MECHANICAL INSTALLATION REQUIREMENTS	2-1
1. VEHICLE DOOR SIZE REQUIREMENTS.....	2-1
2. MINIMUM FLOOR LOADING CAPACITY.....	2-2
3. LIFT LOCATION.....	2-2
4. LIFT INSTALLATION GUIDELINES.....	2-3
B. ELECTRICAL INSTALLATION	2-4
1. ROUTE AND CONNECT MAIN POWER CABLE.....	2-5
2. CONNECT CONTROL PENDANT.....	2-7
3. GROUND (COMMON) CONNECTIONS.....	2-7
4. INTERLOCK DEVICE INSTALLATION.....	2-8
C. FINAL ADJUSTMENTS	2-8
1. LIMIT SWITCH ADJUSTMENT.....	2-8
2. PLATFORM TILT ADJUSTMENT.....	2-10
3. SPLIT PLATFORM TIE ROD ASSEMBLY ADJUSTMENT.....	2-11
4. PLATFORM PRESSURE SWITCH CHECK AND ADJUSTMENT.....	2-12
D. VERIFY INSTALLATION	2-13
E. CUSTOMER ORIENTATION	2-14
III. MAINTENANCE AND REPAIR	3-1
A. LUBRICATION	3-1
B. CLEANING	3-2
C. MAINTENANCE SCHEDULE	3-2
D. TROUBLESHOOTING	3-3
1. LIFT TROUBLESHOOTING.....	3-3
2. PUMP SOLENOID LED STATUS INDICATOR.....	3-4
3. LIMIT SWITCH STATES.....	3-5
E. TOWER ANCHOR GUIDE REPLACEMENT	3-6
F. GAS SPRING REPLACEMENT	3-9
G. MAIN ROLLER ASSEMBLY REPLACEMENT	3-11
H. STOW-LOCK LATCH REPLACEMENT	3-12
I. T-NUT ROLLER REPLACEMENT	3-15
J. PUMP REPLACEMENT	3-16
K. HYDRAULIC CIRCUIT DIAGRAM	3-18
L. ELECTRICAL WIRING DIAGRAM	3-19
1. DIAGRAM LEGENDS.....	3-19
2. WIRING DIAGRAM.....	3-21
IV. SPARE PARTS	4-1
DECAL LOCATIONS AND PART NUMBERS	4-2

SLIDE-AWAY PUMP ASSEMBLY	4-4
SLIDE-AWAY HYDRAULIC SYSTEM	4-6
SLIDE-AWAY ELECTRICAL SYSTEM.....	4-8
SLIDE-AWAY PENDANT & DOOR INTERLOCK SWITCH	4-10
SLIDE-AWAY PLATFORM ASSEMBLY	4-12
SLIDE-AWAY ARMS ASSEMBLY.....	4-14
SLIDE-AWAY BASEPLATE ASSEMBLY	4-16
SLIDE-AWAY ARMRESTS	4-20
APPENDIX 1: LIFT SPECIFICATIONS.....	5-1

I. INTRODUCTION

The Ricon Slide-Away® Export Use wheelchair lift provides wheelchair access to vans. The platform is capable of lifting up to 363 Kgs. The platform is raised with an electro-hydraulic pump and relies on gravity for lowering. The pump has a built-in manual backup pump that allows the platform to be raised or lowered manually. The platform unfolds vertically (along its centerline) while the tower simultaneously slides to the right. Stowing the lift into the vehicle involves the reverse movement. This provides vehicle access through the area where the lift is installed and allows space for the front passenger seat to be adjusted further rearward.

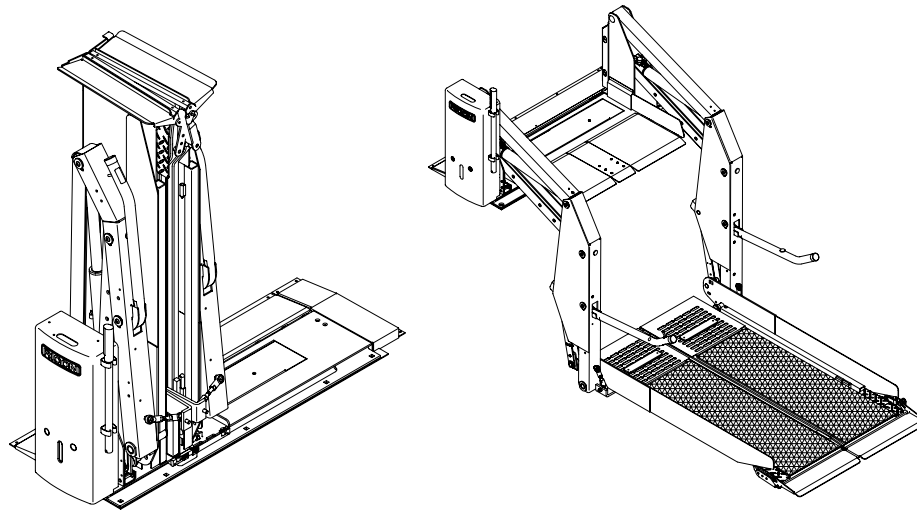

The lift control switches are used to unfold the platform from the vehicle (deploy). The exiting passenger then boards the large non-skid platform and the operator lowers the platform to the ground. After the passenger departs, the platform is raised and folded into the vehicle (stow). The platform folds vertically and the tower slides to the left after rising above floor level.

This manual contains an introduction, installation guide, maintenance and repair instructions, and spare parts. Service of the lift is safer if lift operators are completely familiar with the Operating Instructions chapter of the operator manual (32DSW03). Once the lift is installed, it is important that the lift be properly maintained by following the RICON recommended cleaning, lubrication, and inspection instructions.

If there are questions about this manual, or additional copies are needed, please contact RICON Product Support at one of the following locations:

Ricon Corporation
7900 Nelson Road
Panorama City, CA 91402(818) 267-3000
Outside 818 Area Code(800) 322-2884
World Wide Websitewww.riconcorp.com

Ricon U.K. Ltd.
Littlemoss Business Park, Littlemoss Road
Droylsden, Manchester
United Kingdom, M43 7EF(+44) 161 301 6000

RICON CORPORATION FIVE-YEAR LIMITED WARRANTY

Ricon Corporation (Ricon) warrants to the original purchaser of this product that Ricon will repair or replace at its option any parts that fail because of defective material or workmanship as follows:

- Repair or replace parts for a period of one year starting from the date of purchase. A complete list of parts covered by this warranty can be obtained from an authorized Ricon dealer.
- Labor costs for specified parts replaced under this warranty for a period of one year from the date put into service. A Ricon rate schedule determines parts covered and labor allowed.
- Repair or replace lift power train parts for a period of five years from date of purchase. A complete list of parts covered can be obtained from your authorized Ricon dealer or Ricon.

If you need to return a product: Return this Ricon product to your installing dealer or to Ricon. Please give as much advance notice as possible, and allow a reasonable amount of time for repairs.

If you are traveling: All authorized Ricon dealers honor this warranty. Consult the telephone directory or call our Product Support department for the name of the nearest authorized Ricon dealer.

This warranty does not cover: Malfunction or damage to product parts caused by accident, misuse, lack of proper maintenance, neglect, improper adjustment, modification, alteration, the mechanical condition of the vehicle, road hazards, overloading, failure to follow operating instructions, or acts of nature (i.e., weather, lightning, flood).

NOTE: Ricon recommends this product be inspected by an authorized Ricon dealer or qualified service technician once every six months or sooner, if necessary. Any required maintenance or repair should be performed at that time.

WARNING!

THIS PRODUCT HAS BEEN DESIGNED AND MANUFACTURED TO EXACT SPECIFICATIONS.
ANY MODIFICATION OF THIS PRODUCT CAN BE HAZARDOUS.

This warranty is void if:

- The product has not been installed and maintained by an authorized Ricon dealer or qualified service technician.
- The product has been modified or altered in any respect from its original design without written authorization by Ricon.

Ricon disclaims liability for any personal injury or property damage that results from operation of a Ricon product that has been modified from the original Ricon design. No person or company is authorized to change the design of this Ricon product without written authorization by Ricon.

Ricon's obligation under this warranty is exclusively limited to the repair or exchange of parts that fail within the applicable warranty period.

Ricon assumes no responsibility for expenses or damages, including incidental or consequential damages. Some states do not allow the exclusion or limitation of incidental or consequential damages, so the above limitation or exclusion may not apply.

Important: The warranty registration card must be completed and returned to Ricon within 10 days after installation of this Ricon product for the warranty to be valid. The warranty is not transferable.

The warranty gives specific legal rights. There may be other rights that vary from state to state.

A. SHIPMENT INFORMATION

- Because of the specialized nature of this product, Ricon does not sell directly to the user. Instead, the product is distributed through a worldwide network of authorized Ricon dealers, who perform the actual installation.
- When the product is received, unpack the product and check for freight damage. Claims for any damage should be made to the carrier immediately.
- Be sure the installation kit contains all the items listed on the packing list. Please report any missing items immediately to the Ricon Product Support department. The warranty and owner registration cards must be completed and returned to Ricon within 10 days to validate the warranty.

NOTE: The Sales or Service personnel must review the Warranty and the Operator Manual with the user to be certain that they understand how to safely operate the product. Instruct the user to follow the operating instructions without exception.

B. GENERAL SAFETY PRECAUTIONS

The following general safety precautions must be followed during installation, operation, service, and maintenance:

- Under no circumstances should installation, maintenance, repair, and adjustments be attempted without the immediate presence of a person capable of rendering aid.
- An injury, no matter how slight, must be attended to. Administer first aid or seek medical attention immediately.
- Protective eye shields and appropriate clothing should be worn at all times.
- To avoid injury, exercise caution when operating lift and be certain that hands, feet, legs, and clothing are not in the path of platform movement.
- Batteries contain acid that can burn. If acid comes in contact with skin, immediately flush affected area with water and wash with soap.
- Always work in a properly ventilated area. Do not smoke or use an open flame near battery.
- Do not lay anything metallic on top of battery.
- Check under vehicle before drilling to avoid drilling into frame, subframe members, wiring, hydraulic lines, fuel lines, fuel tank, etc.
- Read and thoroughly understand the operating instructions before operating lift.
- Inspect the lift before each use. If an unsafe condition, such as the presence of unusual noises or movements, do not use lift until the problem is corrected.
- Never load or stand on the platform until the installation is complete. Upon completion of installation, test load the lift mounting integrity at 100% of its rated load capacity.
- Stand clear of doors and platform and keep others clear during operation.
- The product requires regular maintenance. A thorough inspection is recommended at least every six months. The lift must always be maintained at the highest level of performance.

C. EXPORT USE MAJOR LIFT COMPONENTS

The terms used throughout this manual are illustrated in **Figure 1-1** and defined in **Table 1-1**. Refer to Chapter IV "Spare Parts" for more details.

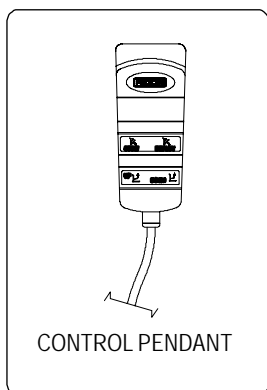
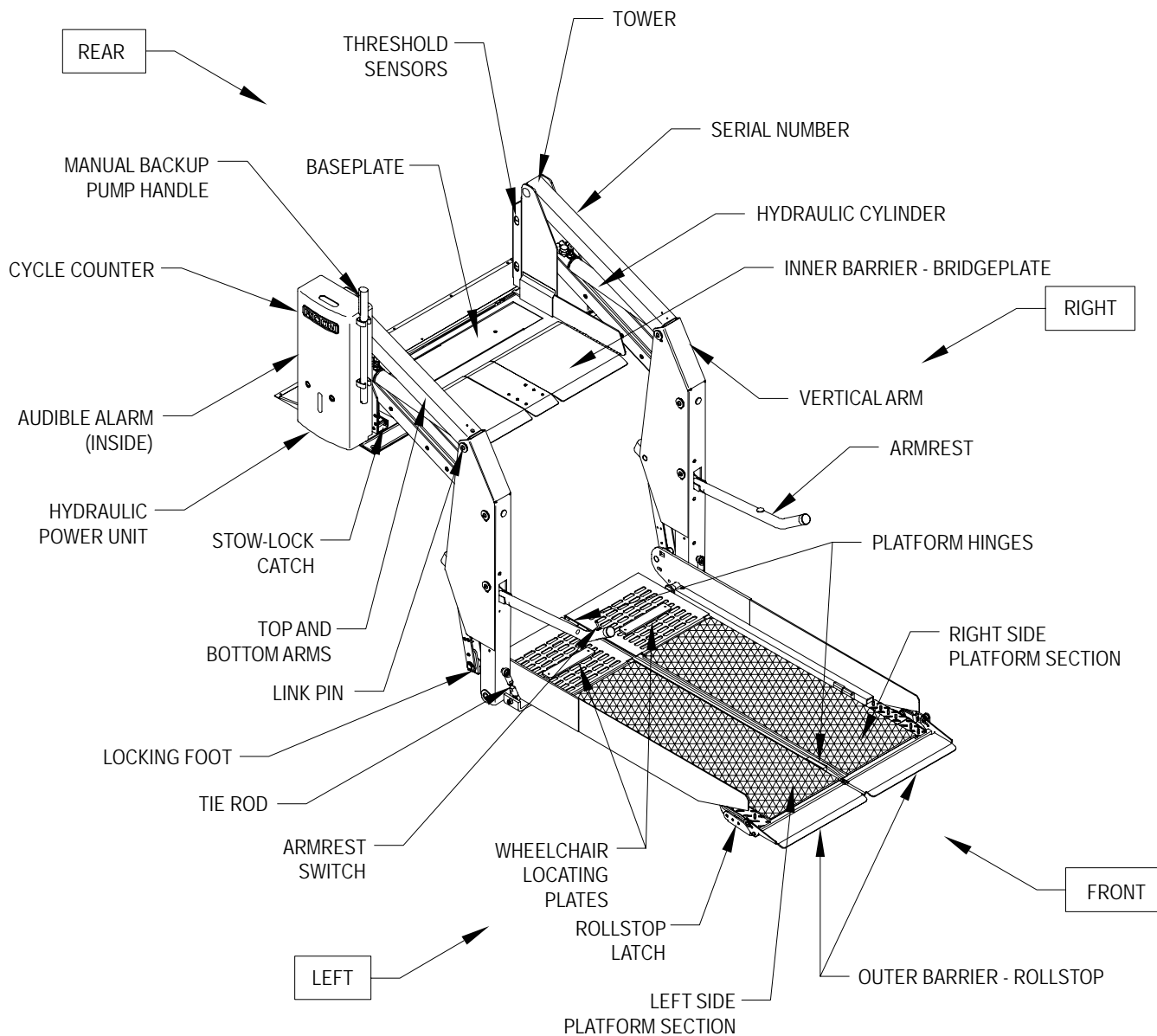

FIGURE 1-1: EXPORT USE MAJOR LIFT COMPONENTS

RSM0021900

TABLE 1-1: SLIDE-AWAY MAJOR COMPONENT TERMS

NAME	DESCRIPTION
Left, right, front, and rear	Position references when installed lift is viewed from outside of vehicle.
Armrest	(left and right) Provides handhold for passenger.
Armrest switch	Allows passenger to control "Up" and "Down" platform motions.
Audible alarm	Announces when something has passed over threshold. Activated by threshold beam.
Baseplate	Bolts to vehicle floor; provides secure foundation for lift structure.
Control pendant	Hand-held device used to control platform motions. Deploy function is not available if vehicle doors are closed.
Cycle counter	Visible at top rear of housing, it records number of times platform has moved from floor to ground and back to floor.
Hydraulic cylinder	(left and right) Telescoping single-acting cylinders convert hydraulic pressure into platform lifting and folding force.
Hydraulic power unit	Contains hydraulic pump driven by electric motor to produce pressure for raising and folding platform, plus a pressure release valve to unfold and lower it.
Inner Barrier	Plate that bridges gap between platform and baseplate when platform is at floor level.
Left side platform section	Left portion of platform that unfolds during deploy and folds during stow.
Link pin	(five per side) Pins that top, bottom, and vertical arms pivot on.
Locking foot	Engages stow lock catch to prevent the platform from drifting outward when fully stowed.
Manual backup pump handle	Used to operate manual back up-pump (located on hydraulic power unit).
Outer Barrier	(left and right) Outer barrier rollostop prevents wheelchair from inadvertently rolling off of platform during platform movement.
Platform hinges	Two hinges provide connection between left and right platform sections.
Right side platform section	Right portion of platform that unfolds during deploy and folds during stow.
Rollstop latch	(left and right) Locks rollstop in up position or unlocks rollstop to allow it to lower.
Serial number	Location of lift serial number decal.
Stow lock catch	Engages lock when platform is fully stowed. (See Locking Foot).
Threshold sensors	(upper and lower) Light-beams detect presence of objects in threshold area.
Tie-Rod	(left and right) Links on split platform that cause platform halves to fold as platform stows.
Top and bottom arms	(left and right) Upper and lower links that connect vertical arms to baseplate.
Tower	(left and right) Supports arms and platform sections when folded or deployed. Right tower slides to right while platform unfolds.
Vertical arm	(left and right) Connects platform to top and bottom arms.
Wheelchair locating plates	Plates that indicate how far back the wheelchair should be positioned on the platform.

END OF TABLE

This page intentionally left blank.

II. INSTALLATION

This chapter contains supplemental information for side installation of the Ricon Slide-Away® Export Use wheelchair lift into full size Ford vans and electrical installation instructions. Custom installations are also possible in other types of vehicles. Due to the wide range of lift applications, specific information for every possible application is not available. Contact the Ricon Product Support department for instruction about installations not covered. Before installing lift, refer to following sections and perform procedures carefully and in the order that they are presented. Be certain that installation instructions are followed exactly and do not eliminate any steps or modify product.

NOTE: The following are supplemental instructions to the installation instructions supplied with the lift. Where these procedures conflict, the supplied installation instructions take precedence. Both instructions must be read and understood completely before attempting installation.

A. MECHANICAL INSTALLATION REQUIREMENTS

1. VEHICLE DOOR SIZE REQUIREMENTS

Refer to **Figure 2-1** and **Table 2-1**.

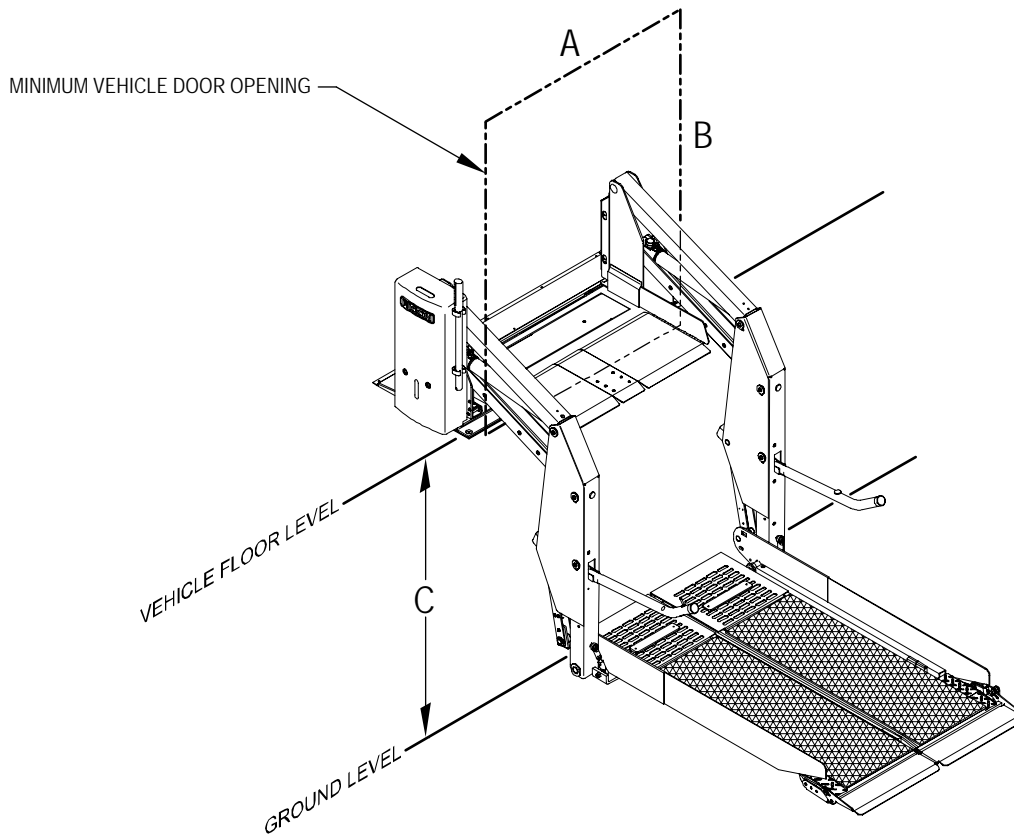

RSM0022000

FIGURE 2-1: MINIMUM DOOR SIZE REQUIREMENTS

TABLE 2-1: REQUIRED DIMENSIONS FOR VEHICLE DOOR OPENING			
MODEL	A (width)	B (height)	C (floor to ground travel)
Millimeters (Inches)			
ST00	984.25 (38.75)	1206.5 (47.5)	762.0 (30.0)
ST01	984.25 (38.75)	1358.9 (53.5)	762.0 (30.0)

2. MINIMUM FLOOR LOADING CAPACITY

Refer to **Figure 2-2** and **Table 2-2**. Rated load and test load are 363 kg (800 lbs).

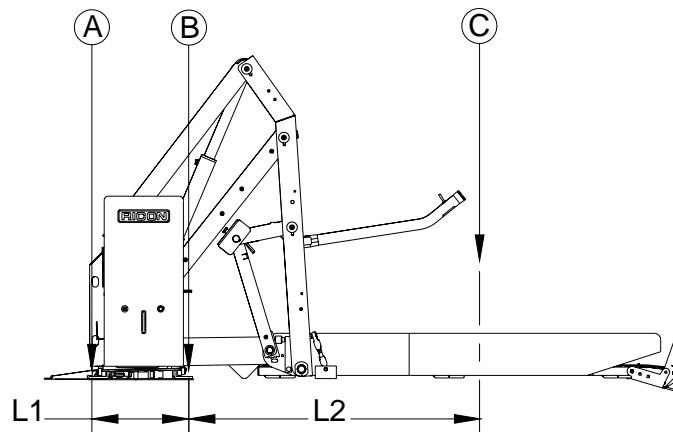

FIGURE 2-2: MINIMUM FLOOR LOAD CAPACITY

TABLE 2-2: LIFT LOADS					
MODEL	L1	L2	A *	B **	C
ST00	279 mm	921 mm	3587 kg	4676 kg	1088 kg
ST01	279 mm	1054 mm	4107 kg	5195 kg	1088kg

* The numbers in column A are the tensile load that is pulling upward at the baseplate rear edge mounting holes.

** The numbers in column B are the compressive load that is pushing downward at the baseplate front edge mounting holes.

3. LIFT LOCATION

The installation surface must be flat and level. If plywood or carpet is present, remove plywood or carpet under lift to provide steel-on-steel contact between the lift and vehicle floor. This will help prevent the mounting bolts from loosening over time. If door operators are to be used, install them prior to lift installation.

NOTE: Check for proper travel clearance through doorway.

- a. With doors fully open, place/position lift in vehicle doorway as close as possible to door, with lift's baseplate assembly parallel to side of vehicle.

⚠ **WARNING!**

LIFT WEIGHT IS APPROXIMATELY 163-177 KG. USE EXTREME CARE WHEN POSITIONING BECAUSE BRACKETS MAY TIP. THIS PROCEDURE MUST NOT BE ATTEMPTED BY ONE PERSON.

- b. Allow a distance of 19mm, if possible, between door and the part of lift closest to it. Adjust lift left and right-side locations to accommodate subframe members.
- c. Verify proper clearance of door frame, passenger seats, and outer edge of vehicle floor, and possible interference with wires, fluid lines, subframe members, etc.

4. LIFT INSTALLATION GUIDELINES

The lift mounting is a very important step. Improper mounting or fastening of baseplate can adversely affect lift performance. Although fastening details may vary from one vehicle to the next, these general principles apply:

⚠ CAUTION!

Lift must be installed on flat and level floor. Use a right angle to ensure baseplate is level with the floor. If baseplate is warped more than 1/4", the vertical arms will not be parallel. Additional shims may be used to keep baseplate level.

- ◆ Be sure to install lift on flat and level floor. Use a right angle to ensure baseplate is level with the floor. If baseplate is warped more than 1.59 mm, shim as required.
- ◆ Be certain baseplate is flush against vehicle floor.
- ◆ Before drilling, verify that lift position does not interfere with closing of vehicle doors or operation of passenger seats.

⚠ CAUTION!

Before drilling holes, verify that underlying wires and tubing will not be damaged.

- ◆ Be certain that all mounting bolts are properly installed and tightened. Bolts used to fasten baseplate assembly to vehicle floor must have a minimum strength rating of SAE Grade 5 and torqued to 28 ft lbs, dry. The most important bolts are those along the rear of lift, since these bolts retain the majority of the load.
- ◆ Refer to **Figures 2-3**. Improper torquing sequence of baseplate bolts may result in a warped or bowed baseplate, which can cause the platform to move erratically.

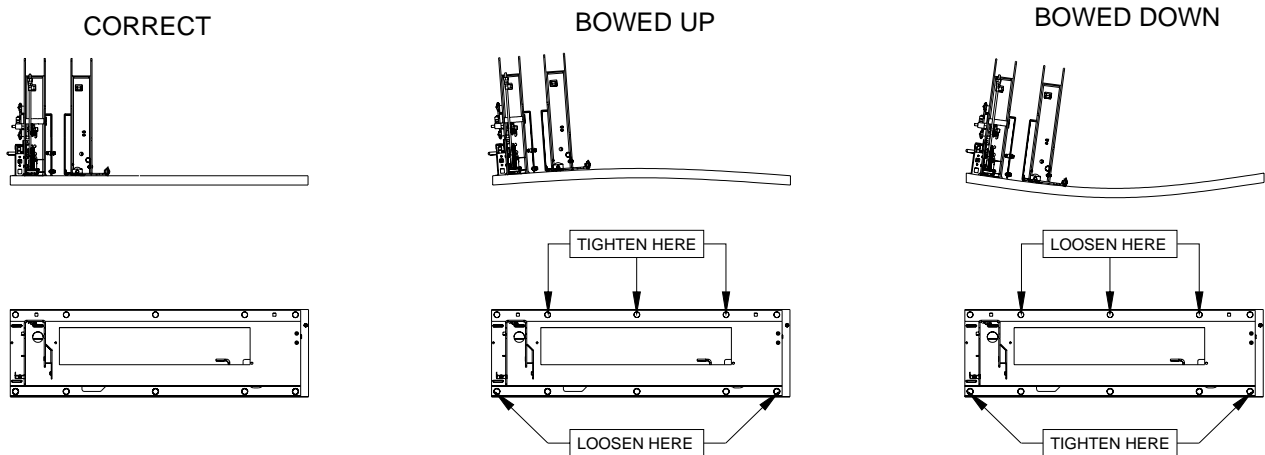

FIGURE 2-3: DISTORTED BASEPLATE

B. ELECTRICAL INSTALLATION

⚠ CAUTION!

- Do not route a wire if it is connected to the battery.
- Route wires clear of moving parts, brake lines, and the exhaust system. Secure wires to the vehicle.
- When routing an electrical wire through vehicle floor or walls, use a grommet to protect wire insulation from chafing.
- Check underside of vehicle before drilling to avoid damage to fuel lines, vent lines, brake lines, or wiring.

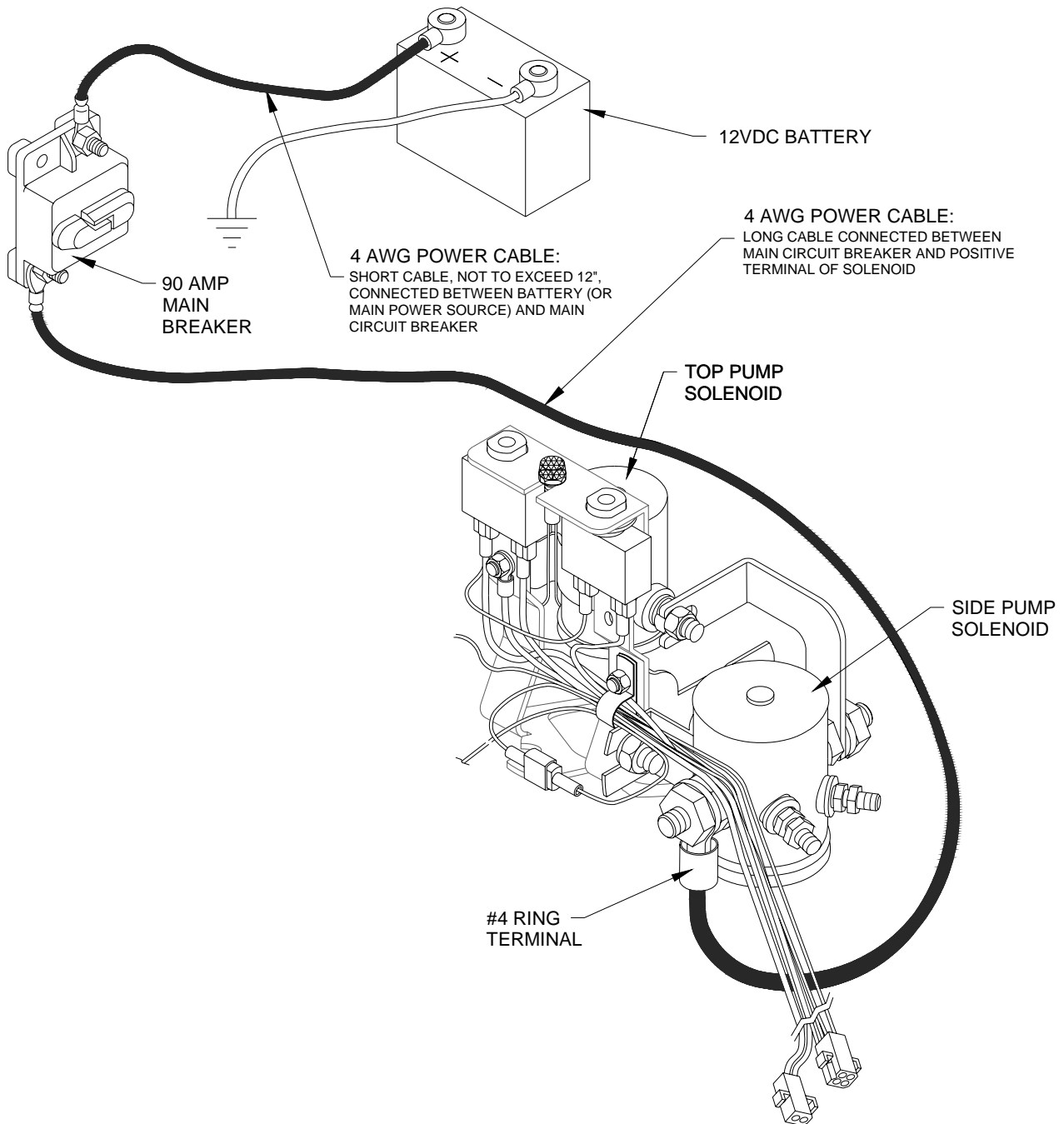

FIGURE 2-4: ELECTRICAL INSTALLATION DIAGRAM

1. ROUTE AND CONNECT MAIN POWER CABLE

- a. Fasten the supplied main circuit breaker within 250 – 300mm of battery (this will minimize the length of exposed cable).
- b. Refer to **Figures 2-4** and **2-5**. Drill one 19mm diameter hole through vehicle floor adjacent to base of hydraulic pump unit. Deburr hole and install grommet. If necessary, cut away any flooring material that is within ¼" of hole.

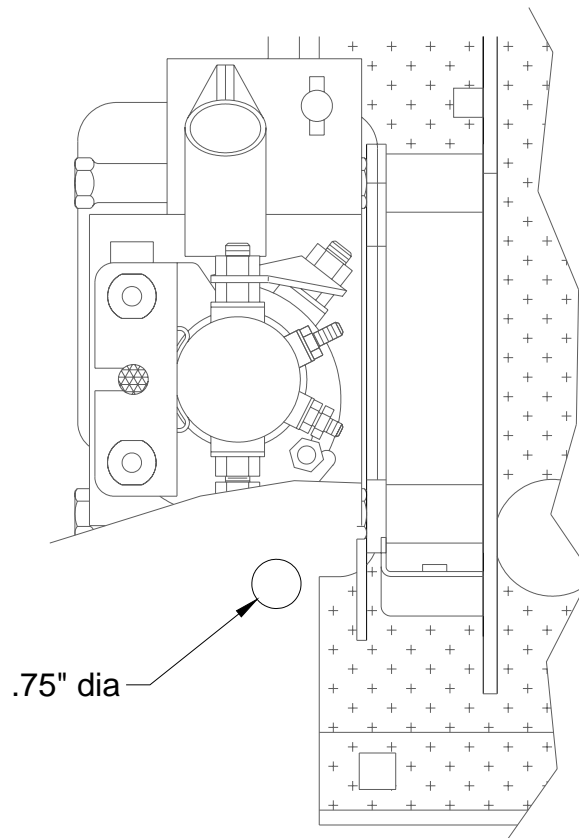

FIGURE 2-5: POWER CABLE ACCESS HOLE

- c. From beneath vehicle, insert red power cable through grommet and up to top of pump unit. Strip 13mm of insulation from cable. Using a wire crimper tool (such as Ricon hammer tool, part of kit P/N 01243) crimp a supplied ring terminal to end of cable.

⚠ CAUTION!

Be sure there is no interference with any parts that could damage power cable or other wires.

- d. Refer to **Figure 2-6**. Fasten ring terminal to side pump solenoid. Secure cable to pump assembly (wiring harness, hydraulic hose, etc) with cable ties.

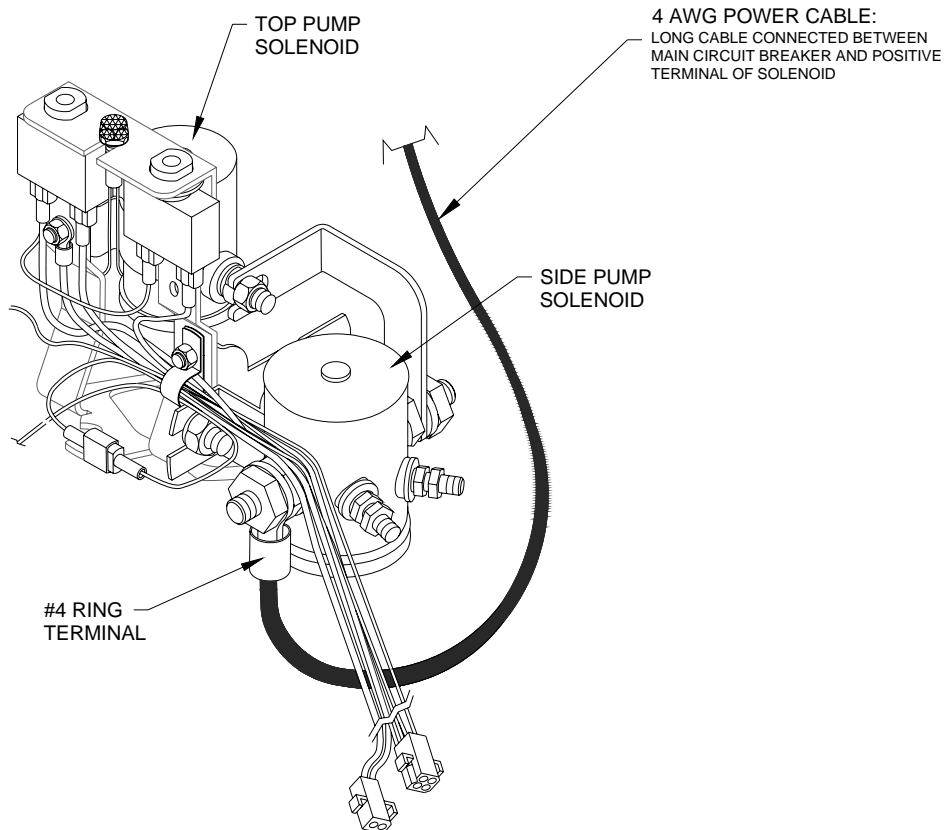

FIGURE 2-6: POWER CABLE CONNECTION TO SOLENOID

- e. From beneath vehicle, run cable along vehicle frame to main circuit breaker. Secure cable with cable clamps every 450mm.
- f. Cut excess length from cable where it reaches circuit breaker. Strip 13mm of insulation from cable.
- g. Crimp a supplied terminal to end of cable and then connect to AUX terminal of circuit breaker.
- h. Cut a 305mm length of cable from the excess previously removed. Strip 13mm of insulation from both ends and crimp supplied terminals to cable.
- i. Connect one end of 300mm cable to BAT terminal of circuit breaker.
- j. Connect other end of cable to positive terminal of vehicle battery.

2. CONNECT CONTROL PENDANT

- a. Refer to **Figure 2-7**. Connect hand-held control pendant to six-pin connector at left side of baseplate and secure cable with supplied cable clamp.

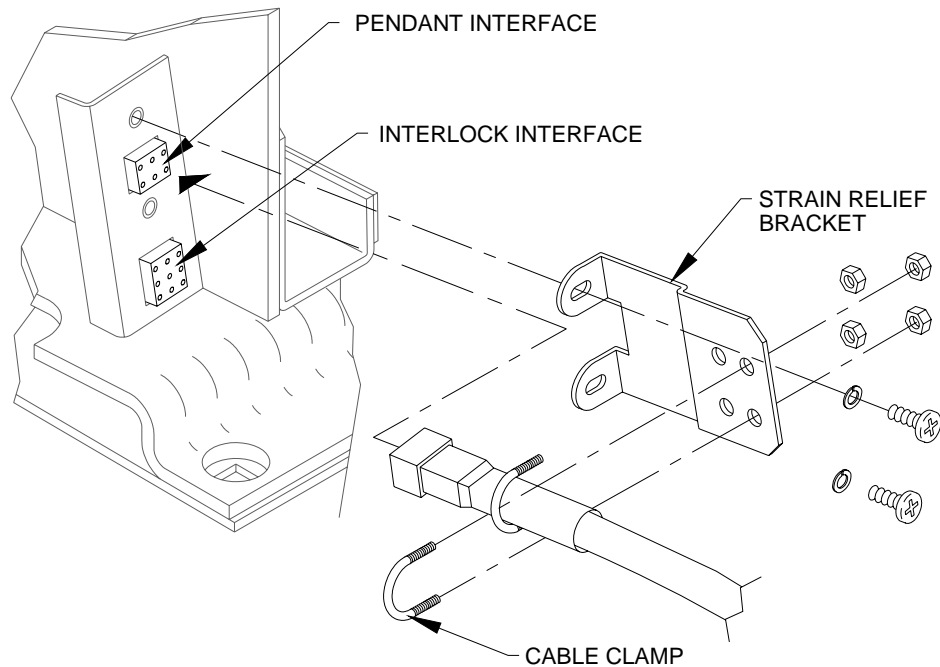

FIGURE 2-7: STRAIN RELIEF KIT

- b. Install wall portion of dovetail clip (pendant storage) in an appropriate and safe location near lift.



3. GROUND (COMMON) CONNECTION

12VDC powered lifts are normally chassis grounded and do not require a separate ground cable connection to battery.

If the common side of the lift electrical system is connected to the chassis with a cable, the cable must be attached in a manner that provides a reliable electrical connection. Refer to kit 13556 (supplied with lift) for instructions explaining the installation of the supplied cable and hardware.

If the ground cable is attached to an existing ground circuit, the circuit must be capable of conducting an additional 90 amps.

4. INTERLOCK DEVICE INSTALLATION

The supplied interlock device must be installed to prevent operation of the lift or vehicle when it is unsafe to do so. The Slide-Away lift provides an electrical interlock signal to the vehicle that prevents movement of the vehicle unless the platform is fully stowed. The interlock control also supplies power to the lift only when the vehicle parking brake is set and the transmission is in PARK.

NOTE: An 8-amp circuit breaker is located within the lift as a circuit protection device. The circuit interface used by the installer must be capable of carrying an additional 8 amps of continuous current.

Refer to **Figure 2-8**. The interlock installation kit provides a display panel for mounting on the vehicle dashboard. The figure shows an LED display panel. The Lift Power LED lights green when the vehicle transmission is in PARK and the parking brake is set. While the LED is green the lift is lowered and the platform can be deployed. The Not Stowed LED lights red when the platform is not fully stowed into the vehicle. While the LED is red the transmission cannot be shifted out of PARK.

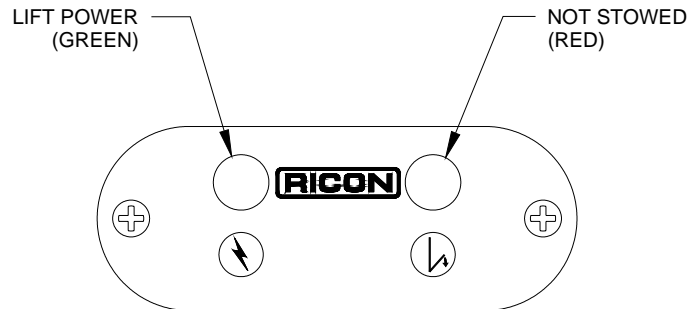

FIGURE 2-8: INTERLOCK DISPLAY PANEL

The installer must verify that none of the original equipment circuit breakers, fuses, or solenoids are bypassed, removed, or altered. Be sure that no wires are left frayed or hanging loose after installation of the interlock device. If you have any questions concerning the proper installation of this interlock device, please contact our Product Support department.

C. FINAL ADJUSTMENTS

1. LIMIT SWITCH ADJUSTMENT

Refer to **Figures 2-9, 2-10**, and the following procedure.

NOTE: To avoid operational “dead-spots”, adjust DEPLOY CUTOFF SWITCH before UP CUTOFF SWITCH.

NOTE: When loosening adjustment screws, apply enough pressure to screw to move block instead of screw. (The block might stick if insufficient pressure is applied to screw.)

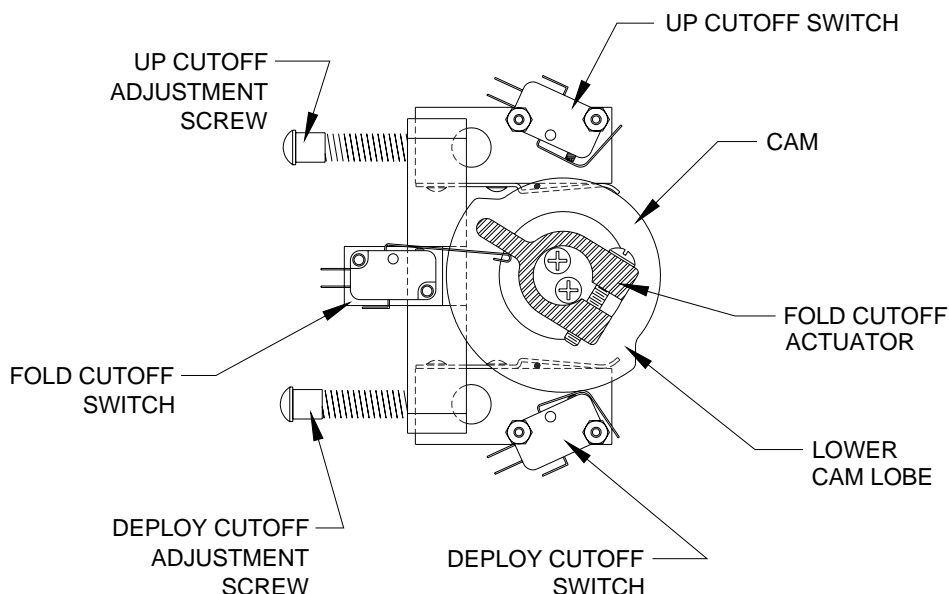

FIGURE 2-9: LIMIT SWITCH ADJUSTMENT DIAGRAM

- a. Fully DEPLOY platform.
- b. Adjust UP CUTOFF ADJUSTMENT SCREW and DEPLOY CUTOFF ADJUSTMENT SCREW 6-8 turns **counterclockwise** and then push screws FORWARD.
- c. Cycle platform to STOW then DEPLOY.
- d. When in DEPLOY position, platform should stop at an angle and NOT even with vehicle floor. If not, turn DEPLOY CUTOFF ADJUSTMENT SCREW an additional 2-3 turns **counterclockwise**, push screw forward, STOW then DEPLOY platform, then repeat this step.
- e. Cycle platform to UP position.
- f. When in UP position, platform should stop short of vehicle floor level. If not, turn UP CUTOFF ADJUSTMENT SCREW an additional 2-3 turns **counterclockwise**, push screw forward, cycle platform DOWN then UP, then repeat this step.
- g. Cycle platform to STOW then DEPLOY.
- h. Push and hold control pendant DEPLOY switch. Slowly turn DEPLOY CUTOFF ADJUSTMENT SCREW **clockwise** until platform “jogs” down to vehicle floor level. Make sure that clearance between knuckle actuator saddle and parallel arm is 3mm minimum (distance may be 19mm maximum and unequal from left or right arm), stop turning screw and release DEPLOY switch.

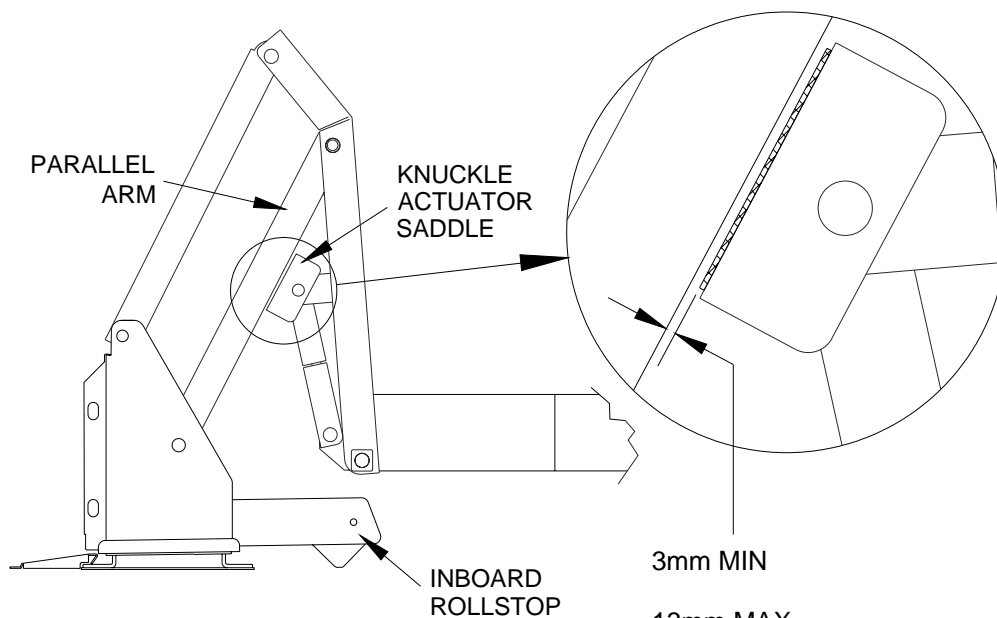

FIGURE 2-10: KNUCKLE ACTUATOR SADDLE CLEARANCE

- i. Position platform DOWN to ground level then UP until it stops.
- j. Push and hold control pendant UP switch. Slowly turn UP CUTOFF ADJUSTMENT SCREW **clockwise** until platform “jogs” up to vehicle floor level. Make sure that clearance between knuckle actuator saddle and parallel arm is 3mm minimum (distance may be 13mm maximum and unequal from left or right arm), stop turning screw and release UP switch.

NOTE: If lift does not operate after 1-2 full turns of adjustment screw, cycle platform UP and DOWN (The UP CUTOFF SWITCH is less sensitive than DEPLOY CUTOFF SWITCH.)

- k. Cycle platform through all functions (DEPLOY, DOWN, UP, and STOW) to verify correct adjustment. Refer to **Table 2-1** if necessary.

TABLE 2-3: LIMIT SWITCH ADJUSTMENT CHART			
COMPONENT	SYMPTOM	CORRECTIVE ACTION	ADJUSTMENT PROCEDURE
Fold cutoff actuator	Lift does not fold tightly.	Rotate actuator counter-clockwise.	With lift fully folded (handrails should be folded tight against vertical arms), rotate actuator so that it barely trips fold cutoff switch.
	Pump runs continuously.	Rotate actuator clockwise.	Test lift. Pump should cutoff when lift is folded tight.
Up cutoff adjustment screw	Lift stops low.	Adjust screw clockwise.	Adjust up cutoff switch so that lift stops just before first knuckle actuator saddle or roller touches underside of lower parallel arm. (Saddle or roller should be about 1/8" from lower parallel arm.)
	Lift stops high.	Adjust screw counter-clockwise.	
Deploy cutoff adjustment screw	Lift stops low.	Adjust screw counter-clockwise.	Adjust deploy limit switch so that lift stops just below "Up" cutoff described in above step. This will give the necessary overlap to avoid "dead" spots.
	Lift stops high.	Adjust screw clockwise.	
END OF TABLE			

2. PLATFORM TILT ADJUSTMENT

Correct platform tilt adjustment is crucial for proper platform rollstop operation, but cannot be adjusted at factory. Factors such as vehicle floor height, lift tilt angle and stiffness of vehicle springs will vary installation geometry.

- a. Deploy and lower lift platform to ground level.
- b. Refer to **Figure 2-11**. Adjust left and right platform set screws until platform is level at zero degrees. Turn setscrews clockwise to angle front-end of platform upward, or counter-clockwise to angle downward.

NOTE: At ground level, the distance between heel of platform and ground should be 19mm to 25mm. This distance should be measured at initial point of rollstop full deployment.

NOTE: Adjust setscrews on both sides of platform simultaneously and evenly to ensure proper leveling of platform.

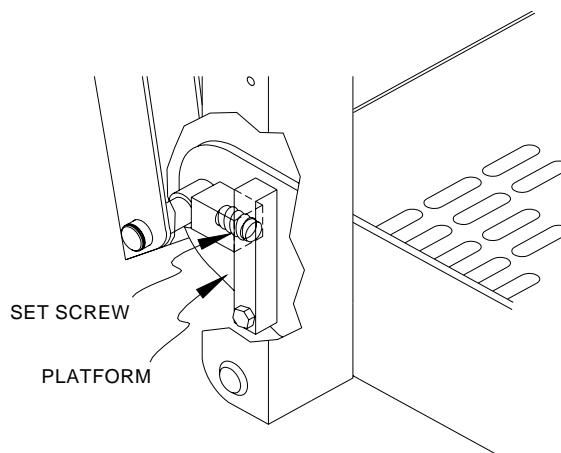



FIGURE 2-11: PLATFORM SET SCREWS

- c. Repeat steps a and b as required to achieve proper rollstop operation.

3. SPLIT PLATFORM TIE ROD ASSEMBLY ADJUSTMENT

Slide-Away lifts are equipped with left and right tie rod assemblies, which fold or unfold the platform panels as the lift is stowed and deployed. Correct adjustment of these tie rods is needed to prevent tie rod breakage.

- a. Lower platform to ground level.

 CAUTION!
Do not lengthen either tie rod assembly to point where platform panel will lift off its support tab .

- b. Refer to **Figure 2-12**. Adjust left and right tie rod assemblies. Loosen jam nuts and then lengthen or shorten tie rod studs until there is a minimum of free-play in tie rod assemblies. Tighten jam nuts.

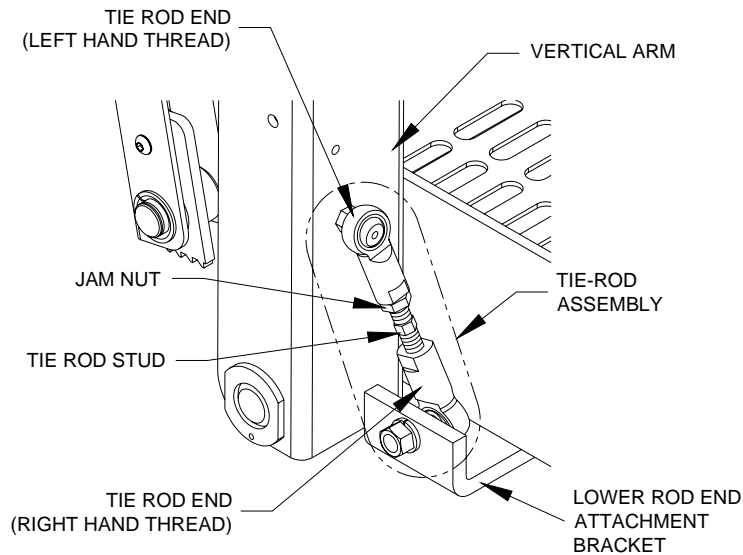

FIGURE 2-12: ADJUSTMENT HARDWARE FOR PLATFORM FOLDING LINKAGE

NOTE: There must be no tension or compression on either tie rod assembly when platform is at, or below, floor level.

- c. Stow and deploy lift several times to verify the platform folds correctly. Readjust tie rod assemblies, if necessary.

4. BRIDGEPLATE ADJUSTMENT

Refer to **Figure 2-13**. Due to the variety of vehicles in which this product is installed on, adjustment of the bridgeplate may be necessary. Screws can be adjusted to raise or lower bridgeplate so platform and bridgeplate edge do not touch during normal operation.

- a. Raise platform slowly.
- b. Adjust screws to ensure that bridgeplate edge overlaps at least 1.25" of platform.

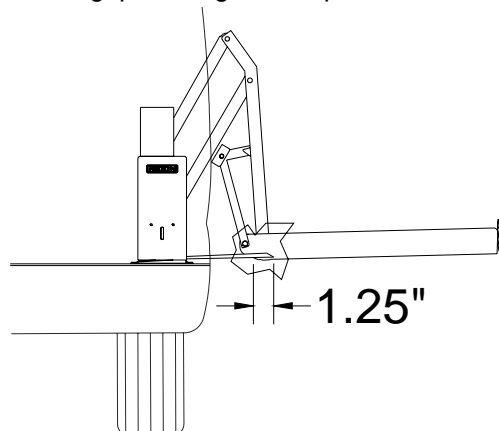

FIGURE 2-13: ADJUSTMENT OF BRIDGEPLATE

5. PLATFORM PRESSURE SWITCH CHECK AND ADJUSTMENT

Correct adjustment of this pressure switch will prevent platform from folding into vehicle when there is a load of 23kg (50 lbs.) or more, on the platform.

- a. Refer to **Figure 2-14**. Deploy and lower platform to ground. Place a 23kg (50 lb.) load in center of platform and then raise platform to floor level. Press and hold STOW switch.

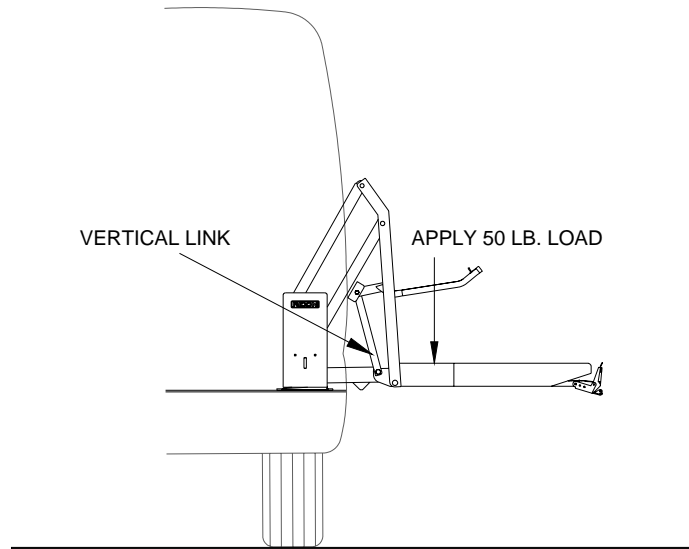

FIGURE 2-14: PRESSURE SWITCH TEST AT FLOOR LEVEL

- b. The pressure switch is correctly set if pump motor shuts off, preventing inward movement of platform. There should not be excessive on/off clicking of pump motor that would indicate switch is marginally set. Proceed to next step if pump motor does not shut off.
- c. Refer to **Figure 2-15**. Remove the 1/4-20 x 25mm setscrew (with hex recess) from end of pressure switch to gain access to adjustment screw. Save setscrew for reinstallation.

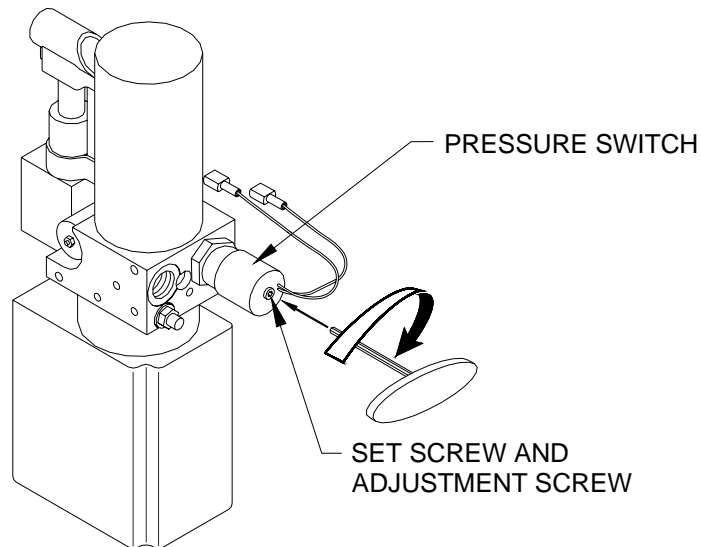
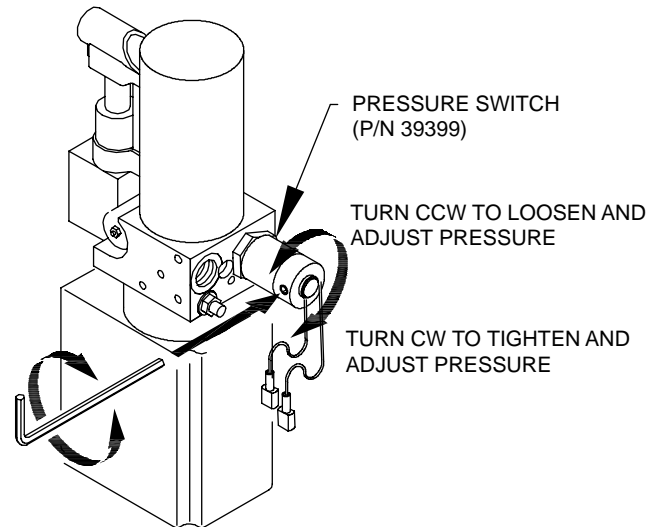

FIGURE 2-15: HYDRAULIC PUMP WITH PRESSURE SWITCH

- d. Insert a 3mm hex wrench into pressure switch and engage adjustment screw inside. Turn screw 1/8 turn clockwise, and then repeat 23kg load check described above. Repeat adjustment, as necessary, to achieve correct setting.
- e. Reinstall setscrew and tighten against adjustment screw.

NOTE: This procedure is for a hydraulic pump with a hydraulic pressure switch that is adjusted by turning the pressure switch enclosure, by hand.

- f. Refer to **Figure 2-16**. Loosen the locking set screw from the hydraulic pressure switch, using a 5/64" hex wrench to allow adjustment of the hydraulic pressure switch.



RSM0005000

FIGURE 2-16: HYDRAULIC PUMP WITH PRESSURE SWITCH

- g. Turn the hydraulic pressure switch enclosure 1/8 of a turn CW, by hand.

NOTE: Turn the hydraulic pressure switch enclosure CW to increase pressure and CCW to decrease pressure, by hand. Stow the platform to test if the motor shuts off. It should not stow with the weight on. Repeat adjustment as necessary to achieve correct setting.

- h. Tighten the locking set screw after adjustment.

D. VERIFY INSTALLATION

- Be certain that no vehicle components interfere with operation of lift.
- The lift is designed to carry the weight of a wheelchair and its passenger. The vehicle structure must be capable of supporting all loads produced during lift operation as well as those forces caused by motion of vehicle when it is driven.

 CAUTION!	
<ul style="list-style-type: none">• Lift <u>must</u> be installed on flat and level floor. Use a right angle to ensure baseplate is level with the floor. If baseplate is warped more than 1.59mm, the vertical arms will not be parallel. Additional shims may be used to keep baseplate level.• Do not operate lift when test weight is on platform. This load test is designed to test the lift mounting method, not the lift capacity. Remove test weight immediately after check.• Vehicle suspension will compress and vehicle will lean when test weight is placed on platform. If weighted platform contacts ground, remove weight, raise platform, and retest.	

- Ricon recommends that the lift be test loaded at its rated 363kg load capacity to verify integrity of installation. Position lift platform 50mm – 150mm above the ground, place 363kg in center of platform, and inspect lift mounting brackets and hardware. Remove test weight.
- Run lift through several complete cycles while checking for proper operation.
- Refer to decals illustration, **Figure 4-1**, in the Spare Parts chapter of the Service Manual (32DSW04). Inspect for chipping, peeling, fading, and illegibility. Order replacement decals with the part numbers given in **Figure 4-1** and apply where shown.

NOTE: The installing dealer affixes an Operating Instructions decal to vehicle in a location clearly visible to the lift operator.

A. CUSTOMER ORIENTATION

IMPORTANT

- Customer Orientation -

Ricon Sales or Service personnel must review the warranty card and operator manual with the customer to be certain they understand how to safely operate the lift. The customer should be instructed to follow the operating instructions without exception.

III. MAINTENANCE AND REPAIR

Regular maintenance of the Ricon Slide-Away® Export Use wheelchair lift optimizes its performance and reduces the need for repairs. This chapter contains lubrication and cleaning instructions, a maintenance schedule, troubleshooting section, and maintenance diagrams.

! CAUTION!

This Ricon product is highly specialized. Maintenance and repairs must be performed by an authorized Ricon dealer or qualified service technician using Ricon replacement parts.

A. LUBRICATION

! CAUTION!

Do not lubricate motor or other electrical components. Lubrication of electrical components may collect dirt and debris, causing short circuits.

Lubrication should be performed at least every six months or sooner depending on usage. Refer to **Figure 3-1** and the following Maintenance Schedule. Lubricate lift at points indicated with lubricants specified.

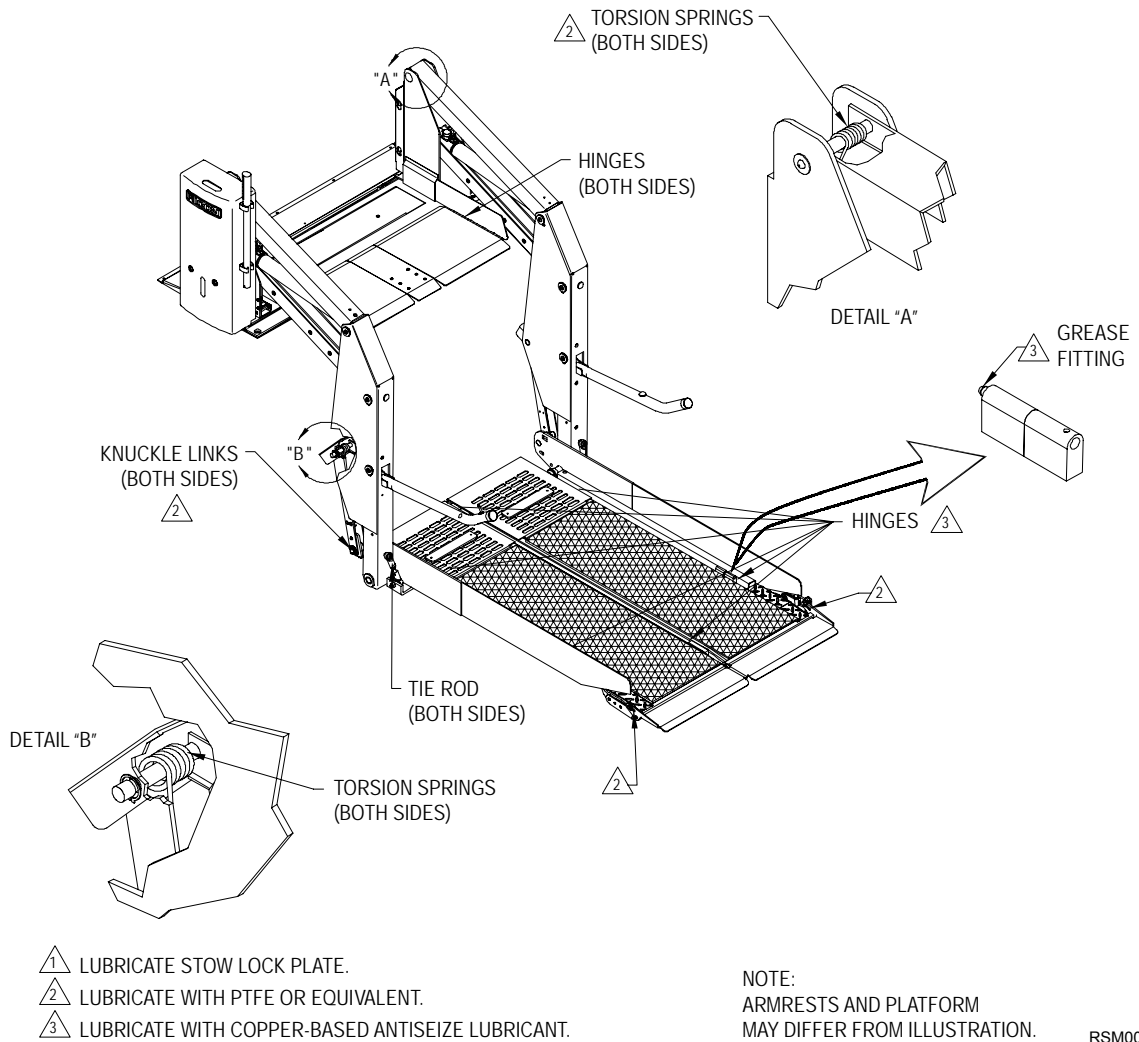

FIGURE 3-1: LIFT LUBRICATION POINTS

B. CLEANING

Regular cleaning with mild soap (i.e. hand soap, car wash liquid) and drying thoroughly will protect lift painted surfaces. Cleaning is especially important in areas where roads are salted in winter. Make sure that lift pivot points remain clear and clean prior to lubrication.

C. MAINTENANCE SCHEDULE

Under normal operating conditions, maintenance inspections are required at service increments referenced in **Table 3-1**. Service should be increased under conditions of heavy use (more than 10 cycles per day.)



TABLE 3-1: MAINTENANCE SCHEDULE	
SERVICE POINT	ACTION TO PERFORM
DAILY OPERATION	
Overall condition	Listen for abnormal noises as lift operates (i.e. grinding or binding noises.)
Control pendant	Verify that control pendant is undamaged and cable connector is tight.
Threshold warning system	Verify that system properly detects objects in the threshold area and actuates the audible alarm.
200 CYCLES	
Overall condition	<ul style="list-style-type: none"> ▪ Inspect underside of vehicle for anything that is out of place.
Electrical wiring	<ul style="list-style-type: none"> ▪ Inspect electrical wiring for frayed wires, loose connectors, etc.
Vehicle interlock	<ul style="list-style-type: none"> ▪ Place vehicle in non-interlock mode and verify that lift does not operate.
Decals	<ul style="list-style-type: none"> ▪ Verify that lift decals are properly affixed, clearly visible, and legible. Replace, if necessary.
Armrests	<ul style="list-style-type: none"> ▪ Verify that armrest fasteners are properly tightened.
Lift mounting points	<ul style="list-style-type: none"> ▪ Verify that vehicle mounting and support points are undamaged. ▪ Verify that mounting bolts are sufficiently tight and free of corrosion.
Main lifting pivots	<ul style="list-style-type: none"> ▪ Verify that link pins on arms are properly installed, free from damage, and locked in position.
Platform pivot points	<ul style="list-style-type: none"> ▪ Verify that platform moves freely, without binding, and does not wobble.
Bridgeplate	<ul style="list-style-type: none"> ▪ Verify that bridgeplate operates without binding during lift functions. ▪ Verify bridgeplate rests flat against platform.
Front rollstop	<ul style="list-style-type: none"> ▪ Verify that rollstop is opened completely when platform is at ground level. ▪ Verify that rollstop closes and locks when platform leaves ground.
1000 CYCLES	
Hydraulic power unit	 CAUTION!
	Check and add fluid when platform is at ground level. Fluid that is added when platform is raised will overflow when platform is lowered.
	<ul style="list-style-type: none"> ▪ Verify that pump hydraulic fluid level is at FULL mark when platform is at ground level. Add Texaco 01554 Aircraft Hydraulic Oil or equivalent U.S. mil spec H5606G fluid. ▪ Verify there are no hydraulic fluid leaks. ▪ Verify that manual backup pump operates properly.
Cleaning and lubrication	<ol style="list-style-type: none"> 1. Clean lift with mild soap and water and wipe dry. Prevent rust by coating all surfaces with a light weight oil. Remove excess oil. 2. Spray penetrating oil PTFE or equivalent WD-40® where specified in Figure 3-1 following directions on container. Remove excess grease from surrounding areas. 3. Inspect springs. Replace if worn or damaged.
CONTINUED	

TABLE 3-1: MAINTENANCE SCHEDULE	
SERVICE POINT	ACTION TO PERFORM
Sliding tower	For units with rollers, inspect all rollers at bottom of traveling tower. Rollers must turn freely, be free of flat spots, and secure to the roller axles.
Baseplate tracks	<ol style="list-style-type: none"> 1. Remove baseplate access cover. 2. Clear any debris from front and rear tracks with vacuum then blow out with compressed air. Inspect springs, gas spring, wire cable, electrical harness, and hydraulic lines.
Knuckle actuator saddle	<ul style="list-style-type: none"> Refer to Figure 2-11. Inspect both T-bolts on the knuckle actuator saddle for wear. Verify wear on T-bolts does not exceed 1/8" depth. Replace, if necessary.
2500 CYCLES (ANNUAL SERVICE)	
Hydraulic cylinder, hoses and fittings	 CAUTION!
	A Ricon authorized dealer must perform the following safety check.
	<ul style="list-style-type: none"> Check hydraulic cylinders for any leaks. Retighten cylinder pin retaining fasteners (2 per cylinder). Inspect hydraulic hoses for damage. Replace if damaged. Verify that all fittings are tight. Retighten all hydraulic fittings accordingly. Retighten lift mounting bolts. Replace if damaged or corroded. Retighten set screws securing platform pivot pins at bottom of each vertical arm. Secure with medium strength thread lock compound. Retighten platform pivot pin retaining plate fasteners. Secure with medium strength thread lock compound. Retighten arm pivot pins. Retighten armrest bolts to knuckle assembly.
5000 CYCLES	
Torsion springs, gas springs	 CAUTION!
	A Ricon authorized dealer must perform the following operations.
	<ul style="list-style-type: none"> Replace torsion springs. Replace deploy assist gas springs located in baseplate. Replace both bridgeplate deploy gas springs.
END OF TABLE	

D. TROUBLESHOOTING

The troubleshooting guides are designed to provide logical starting points to locate general problems that could occur with lift. However, not all possible problems or combinations of problems are listed. For troubleshooting lift, refer to **Table 3-2**. The guide does not incorporate routine safety precautions or preliminary procedures, and assumes that vehicle battery is fully charged and battery terminals/connectors are clean and tight.

 WARNING!
<p>THE TROUBLESHOOTING GUIDES DO NOT INCORPORATE ROUTINE SAFETY PRECAUTIONS OR PRELIMINARY PROCEDURES. DURING THE RICON WARRANTY PERIOD ONLY A TRAINED, AUTHORIZED RICON DEALER OR QUALIFIED SERVICE TECHNICIAN CAN PERFORM TROUBLESHOOTING. AFTER THE WARRANTY PERIOD, IT IS RECOMMENDED THAT TROUBLESHOOTING CONTINUE TO BE PERFORMED BY AN AUTHORIZED RICON DEALER OR QUALIFIED SERVICE TECHNICIAN.</p>

1. LIFT TROUBLESHOOTING

TABLE 3-2: LIFT OPERATIONAL TROUBLESHOOTING GUIDE			
SYMPTOM	POSSIBLE CAUSE	REMEDY	
Hydraulic fluid leaks	Loose hydraulic fitting.	Make sure fitting is PROPERLY tightened.	
	Hydraulic component defective.	Repairs must be made by an authorized RICON dealer or qualified service technician before using lift.	
Rollstop does not open	Obstruction of rollstop release latch.	Raise lift and remove obstruction.	
Lift functions	Abnormal operation.	Obstruction in lifting frame.	Remove obstruction and check for any damage
		Backup pump manual release valve OPEN.	Turn manual release valve CLOCKWISE until slightly snug.
		Hydraulic fluid may be low.	While platform is at GROUND LEVEL, be certain that pump hydraulic fluid level is maintained at required FULL level. Add only Texaco 01554 Aircraft Hydraulic Oil or equivalent U.S. mil spec H5606G fluid.
		Air may be trapped in hydraulic system.	Purge hydraulic system by operating lift through its maximum range of travel for at least four complete cycles. (For vehicles that do not use full travel of lift, the maximum range of travel is accomplished by raising vehicle on a service hoist or ramp.)
	No operation.	Control system circuit breaker tripped.	Reset circuit breaker.
		Backup pump manual release valve is OPEN.	Turn manual release valve CLOCKWISE until slightly snug. (CONTINUED)
	Hydraulic hose or fitting leak.	Contact an authorized RICON dealer or qualified service technician for repair.	
	Hydraulic fluid may be low.	While platform is at GROUND LEVEL, be certain that pump hydraulic fluid level is maintained at required FULL level. Add only Texaco 01554 Aircraft Hydraulic Oil or equivalent U.S. mil spec H5606G fluid.	
	Air may be trapped in hydraulic system.	Purge hydraulic system by operating lift through its maximum range of travel for at least four complete cycles. (For some vehicles, the maximum range of travel is accomplished by raising vehicle on a service hoist or ramp.)	
END OF TABLE			

2. PUMP SOLENOID LED STATUS INDICATOR

Refer to **Figure 3-2**. Two motor contactors (solenoids) for the hydraulic pump are located at the top of the pump assembly. A LED status indicator is located between the 30 amp and 8 amp circuit breakers. The LED is green when both contactors are operating correctly and the motor is operating. When the pump is not operating and the top contactor has failed the LED will be red. When the side contactor has failed the LED will be green.

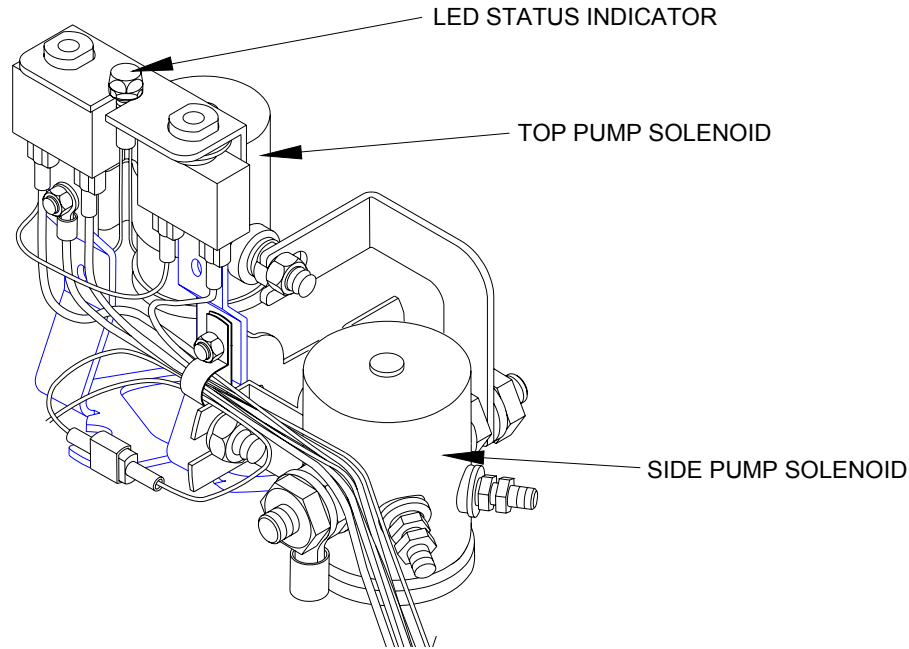
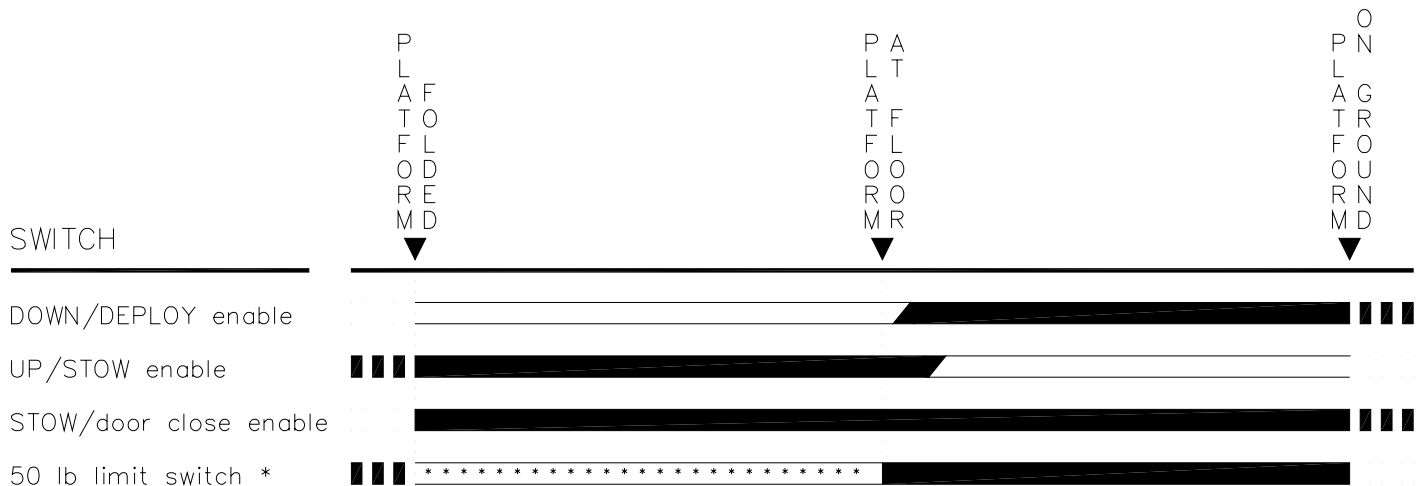

FIGURE 3-2: STATUS INDICATOR FOR PUMP SOLENOIDS

3. LIMIT SWITCH STATES

Refer to **Figure 3-3**. The actuation diagram shows the state of all limit switches as the platform travels from stowed, to vehicle floor level, and then to ground level. The solid line segments (—) represent current flow through the normally CLOSED switch contacts, and the open line segments (=) represent current flow through the normally OPEN switch contacts. The heavy dashed lines (■■■) show switch states when platform is beyond normal travel boundaries. This is useful in showing the operation of switches that change states at stowed or ground level positions. For proper operation of lift, the switch actuations must overlap as shown.



* 50 lb limit switch actuates when weight on platform exceeds 50 lbs during IN platform motion.

FIGURE 3-3: LIMIT SWITCH ACTUATION CHART

E. TOWER ANCHOR GUIDE REPLACEMENT

Note: Tower Anchor Guide and Baseplate Gas Spring replacement may be completed consecutively. Reference notes when consecutive procedure may be completed.

1. Refer to **Figure 3-4**. Deploy platform to ground level. Remove short side ramp and longer rear ramp from around the baseplate to gain access to lower tower components.

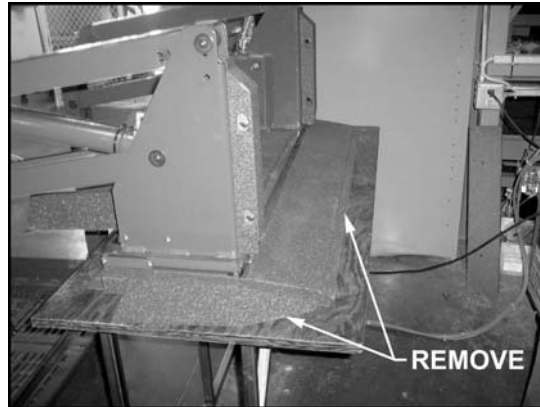

FIGURE 3-4

2. Refer to **Figures 3-5 and 3-6**. Remove center access panel at rear of baseplate.

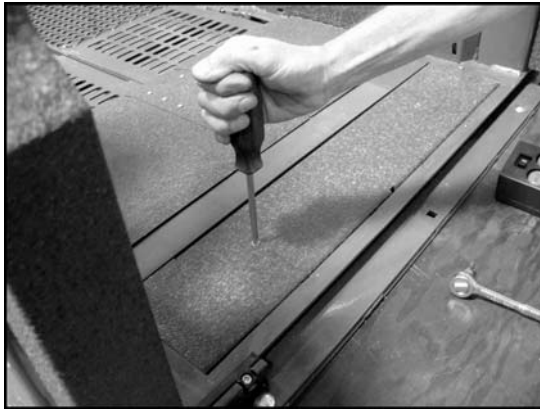

FIGURE 3-5



FIGURE 3-6

3. Refer to **Figure 3-7**. Remove two of the mounting bolts attaching the baseplate to the vehicle.

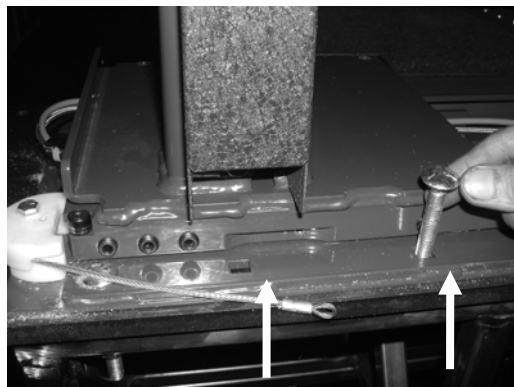

FIGURE 3-7

4. Refer to **Figure 3-8**. Partially stow lift and insert a 6" x 2" x 2" wooden block (or similar) behind gas spring. This will compress gas spring and decrease tension on cable.



FIGURE 3-8

5. Refer to **Figures 3-9 and 3-10**. Deploy platform to floor level. Note slack in cable.



FIGURE 3-9



FIGURE 3-10

6. Refer to **Figure 3-11**. Remove hex screw to detach anchored end of cable. Retain plastic guide for installation if applicable.

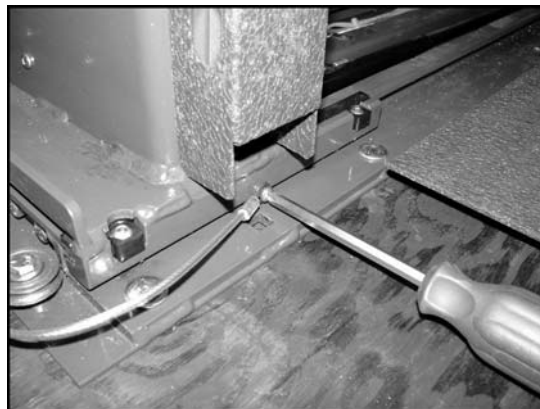

FIGURE 3-11



NOTE

Gas Spring Replacement can be performed at this point. Refer to **Section F** for Gas Spring Replacement.

7. Refer to **Figure 3-12**. Remove clamp-attaching screw on front of roller rail.

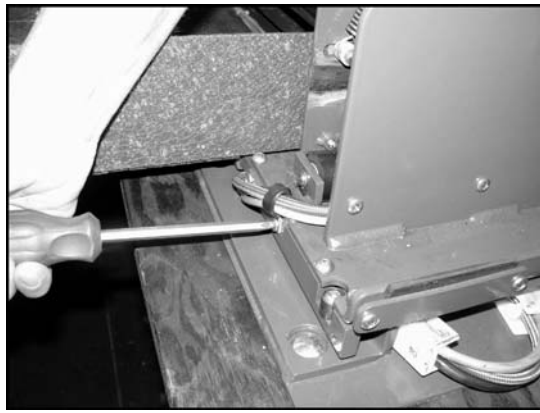

FIGURE 3-12

8. Refer to **Figures 3-13 and 3-14**. Raise bridgeplate by hand. Hold bridgeplate in this position with pin or screwdriver.



FIGURE 3-13



FIGURE 3-14

9. Lower lift to ground and open pump release valve by turning valve counter-clockwise.

 CAUTION
<p>Do not open pump release valve more than ¼ turn. Opening valve further may cause it to disengage from pump body, which will disable manual pump.</p>

Note: The *Threshold Safety Warning System* may be disconnected momentarily while performing replacement procedures.

10. Refer to **Figure 3-15**. Remove the four roller rail-retaining screws located at bottom of sliding tower.
11. Refer to **Figure 3-16**. Push base of sliding tower rearward (about 1") to disengage it from the baseplate. Be prepared to handle its weight.

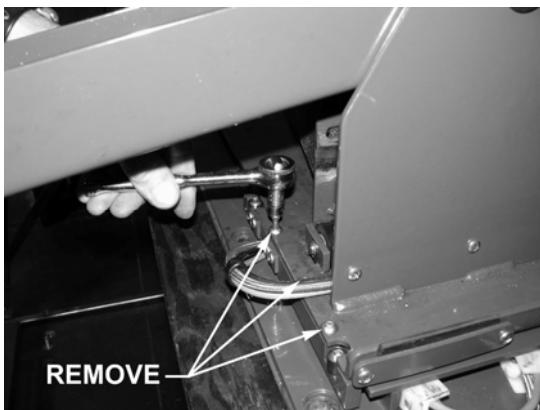

FIGURE 3-15



FIGURE 3-16

CAUTION!

Lift weight is approximately 360-390 lbs. Use extreme care when positioning lift. This procedure may require one additional person.

12. Refer to **Figures 3-17 and 3-18**. Remove the two roller retaining screws and replace rollers.

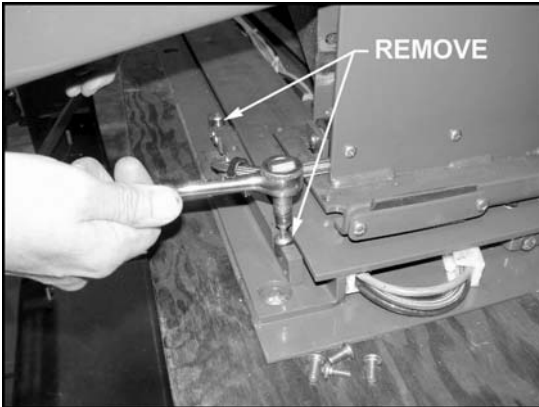

FIGURE 3-17



FIGURE 3-18

13. Refer to **Figures 3-19 and 3-20**. Replace glide block. Remove screws on glide block and replace.

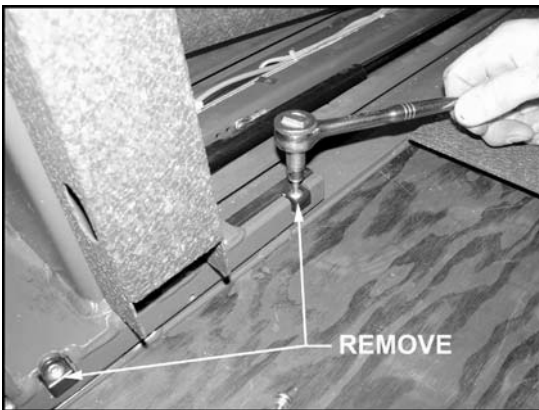

FIGURE 3-19



FIGURE 3-20

14. Re-assembly in reverse order.

Note: When re-assembling, do not apply thread lock on the roller retaining screws. Applying thread lock on screws will prevent the roller from rotating.

Note: Refer to **Figures 3-9 and 3-10**. When re-assembling, note that cable should wrap around grooved bearing. Partially stow lift to remove wood block. Hold cable with pliers when deploying lift to regain tension.

15. Test Deploy and Stow operation of bridgeplate. If required to get bridgeplate to lie flat, apply silicone spray to front rollers and delrin glide block.

F. GAS SPRING REPLACEMENT

1. Refer to **Figure 3-21**. Secure gas spring with pliers for leverage.
2. Refer to **Figure 3-22**. Remove nut that attaches gas spring to baseplate and retain for installation.



FIGURE 3-21

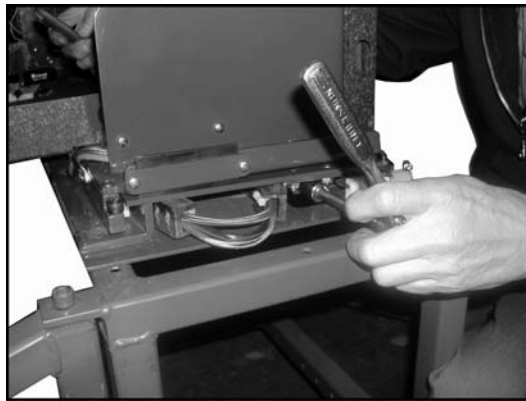

FIGURE 3-22

3. Refer to **Figure 3-23**. Slide gas spring inward then lift and remove from baseplate.

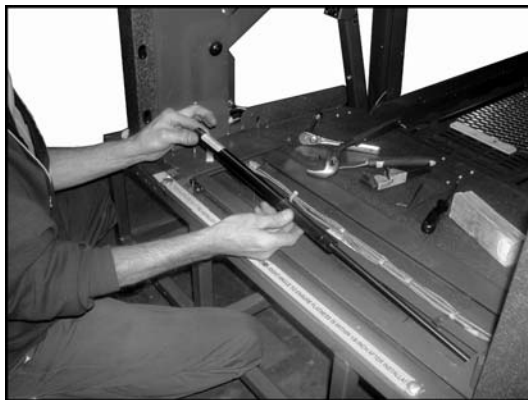

FIGURE 3-23

4. Remove the screw and collar that attaches the cable to baseplate and retain for installation.
5. Remove cable from baseplate. Discard old cable.

NOTE: Do not reuse old cable. Use Cable (P/N 35233) provided in Kit (P/N 36998).

6. Install cable (P/N 35233) and secure with existing screw and collar, retained from step 12, Section E.

NOTE: Do not reuse old cable. Use Cable (P/N 35233) provided in Kit (P/N 36998).

7. Refer to **Figure 3-24**. Install clevis (P/N 35232) onto gas spring (P/N 39368).

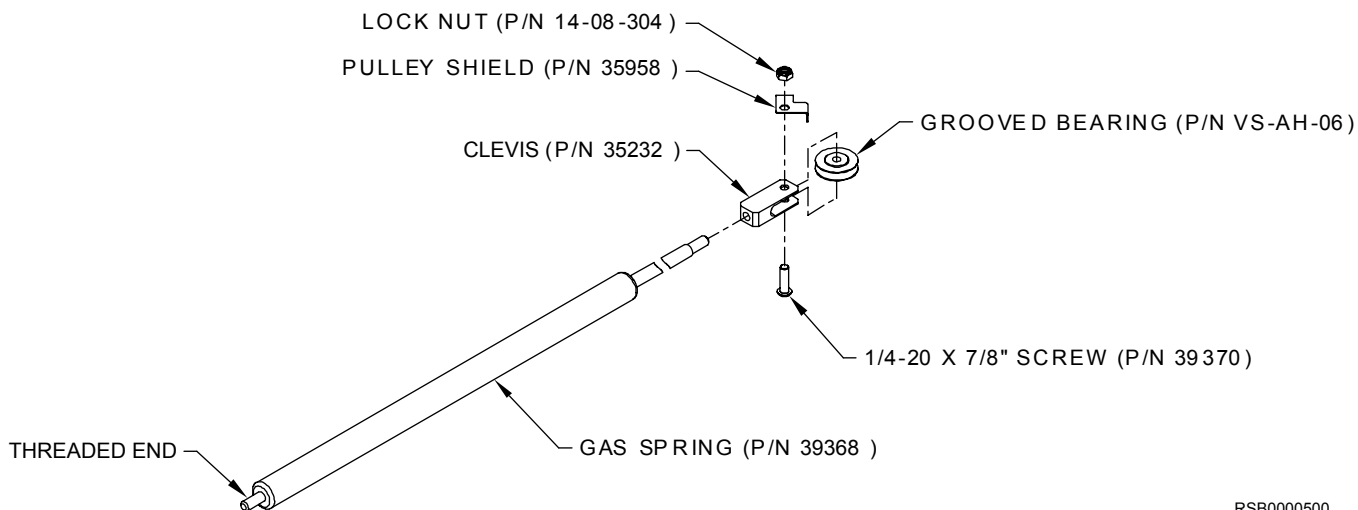

FIGURE 3-24

RSB0000500

8. Refer to **Figure 3-24**. Assemble grooved bearing (P/N VS-AH-06), pulley shield (P/N 35958) and attaching parts onto clevis (P/N 35232). Do not tighten.

NOTE: Do not tighten 1/4-20 screw onto pulley shield with lock nut until cable has been routed onto grooved bearing.

9. Place gas spring (P/N 39368) in baseplate as shown in **Figure 3-23**.
10. Route cable (P/N 35233) onto grooved bearing (P/N VS-AH-06).
11. Tighten ¼-20 x 7/8" screw (P/N 39370) and lock nut (P/N 14-08-304) and secure pulley shield onto clevis.
12. Refer to **Figure 3-25**. Align threaded end of gas spring into bracket hole then fasten to baseplate with nut.

NOTE: Apply medium strength thread lock (Loctite 243) to threaded end of gas spring before installing nut.

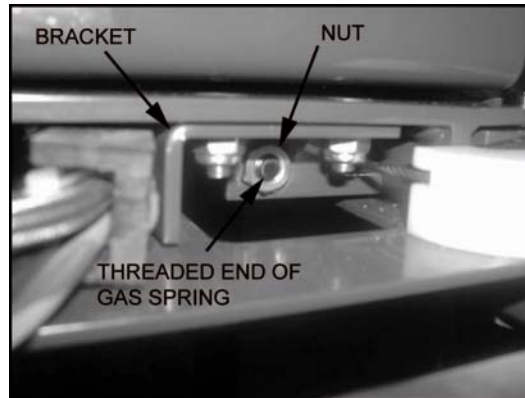

FIGURE 3-25

13. Pull cable and insert wooden block (or similar) in baseplate, as shown in **Figure 3-9**, Section E. Allow slack in cable.
14. Install existing hex screw to anchor the cable end onto the baseplate as shown in **Figure 3-11**, Section E.

NOTE: Ensure that the plastic guide retained from removal procedure is reinstalled.

15. Partially stow lift to remove wooden block (or similar) from baseplate as shown in **Figure 3-8**, Section E. Tension to cable will be restored when wooden block is removed.
16. Replace center access cover and re-install center access cover screws.
17. Deploy and stow lift to ensure that gas spring and cable are working properly.

G. MAIN ROLLER ASSEMBLY REPLACEMENT

A. ROLLER REMOVAL

1. Deploy platform to ground and open pump release valve by turning valve counter-clockwise.

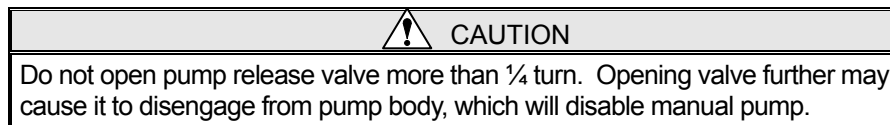

2. Refer to **Figure 3-26**. Remove 3/8" snap ring off the front of 76.2mm long pin retainer.

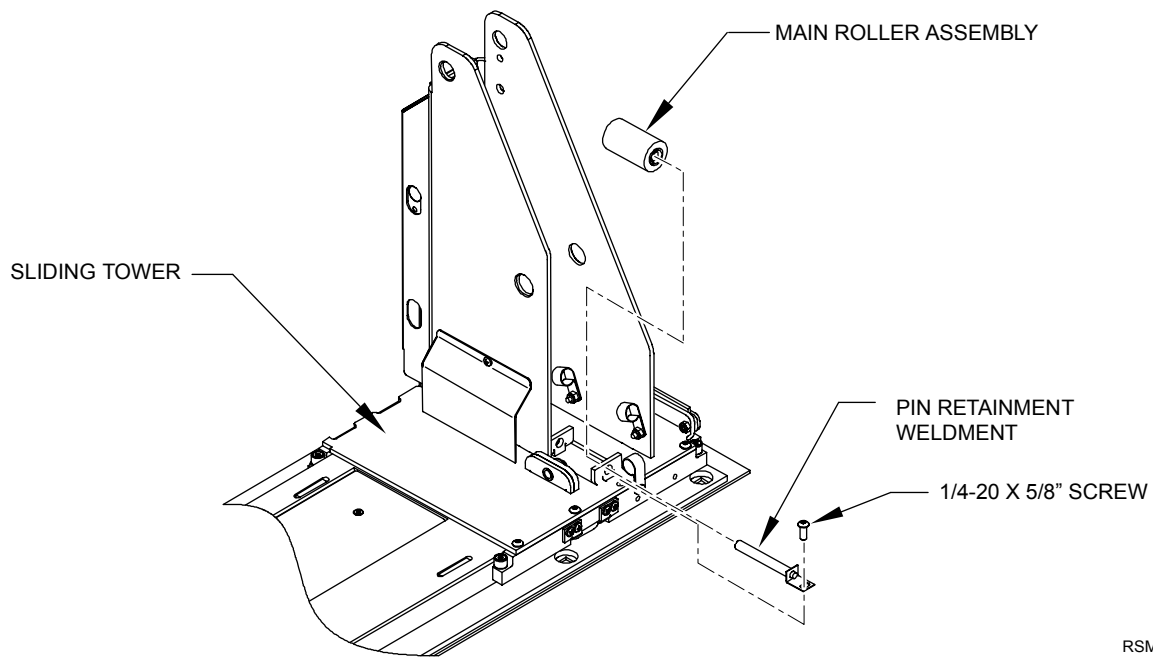

RSM0006701

FIGURE 3-26

3. Refer to **Figure 3-27**. Pry up on front rail to remove lift weight on roller. Push pin bushings and sleeve out.

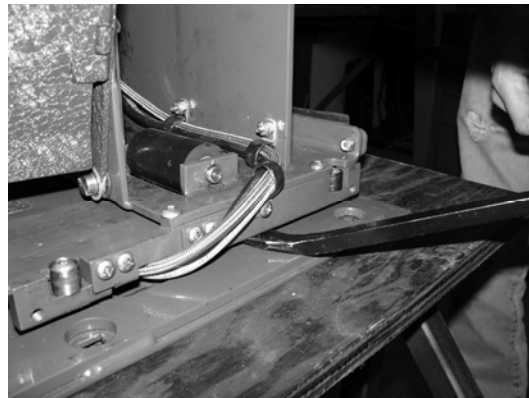

FIGURE 3-27

4. Remove roller assembly and replace with Roller Kit (P/N 34574).
5. Refer to **Figure 3-26**. Align new roller assembly in sliding tower then slide pin retainment weldment through sliding tower and roller assembly.
6. Install 1/4-20 X 5/8" screw to secure pin retainment weldment.
7. Stow and deploy lift to ensure that sliding tower is working properly.

H. STOW-LOCK LATCH REPLACEMENT

1. Deploy platform to vehicle floor level.
2. Remove left side pinch point shields.
3. Refer to **Figure 3-28**. Remove nut and bolt to detach left hand armrest from knuckle arm assembly.



FIGURE 3-27

4. Refer to **Figure 3-28**. Lift left hand armrest to remove rubber washer.

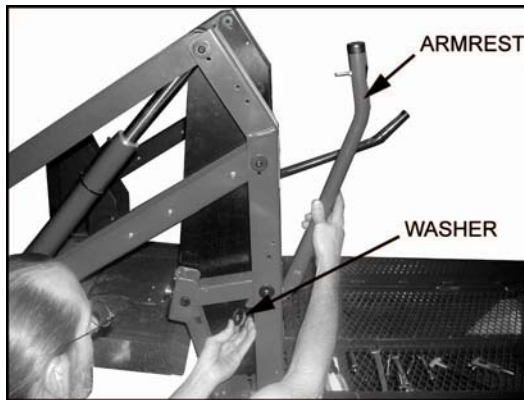

FIGURE 3-28

5. Refer to **Figures 3-29** and **3-30**. Detach snap ring from pin then remove washer and split washer. Retain for installation.

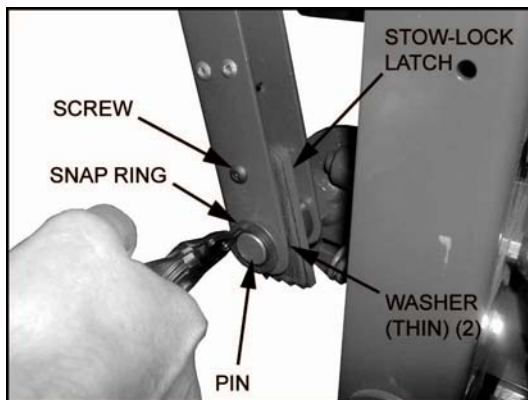

FIGURE 3-29

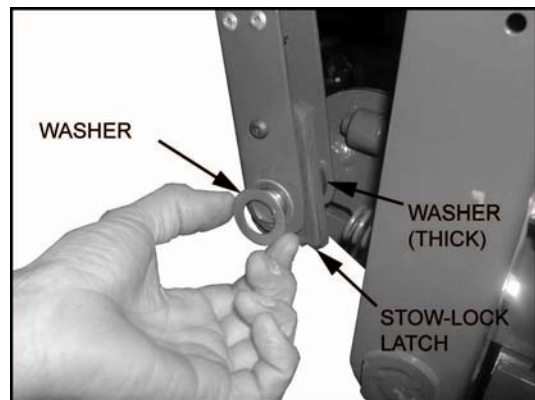

FIGURE 3-30

NOTE: Refer to **Figures 3-29** and **3-30**. When removing knuckle arm assembly from platform pin, detach 2 thin plastic washers and one thick plastic washer. Retain for installation.

6. Refer to **Figure 3-31**. Remove screw and lock washer then remove pin to detach knuckle arm assembly from platform assembly.



FIGURE 3-31

7. Refer to **Figures 3-32**. Remove screw, nut and three plastic washers to detach stow-lock latch from knuckle arm assembly. Retain attaching hardware for installation.

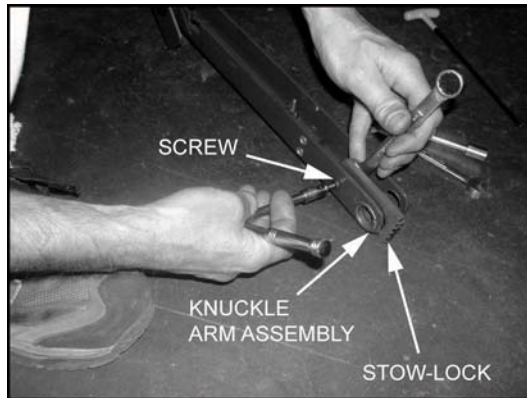

FIGURE 3-32

8. Replace stow-lock latch with (P/N 39943) provided in Kit (P/N 42054).
9. Re-assembly in reverse order.

NOTE: When re-assembling new stow-lock and attaching to knuckle arm assembly, add medium strength thread lock (Loctite 243) to screw.

NOTE: Properly discard old or worn stow-lock latch.

10. Refer to **Figures 3-33 and 3-34**. Remove center access panel at rear of baseplate.



FIGURE 3-33



FIGURE 3-34

11. Refer to **Figure 3-35**. Disconnect solenoid connector.
12. Refer to **Figure 3-36**. Remove screw and nut to detach manual release handle from stow-lock assembly and retain hardware.

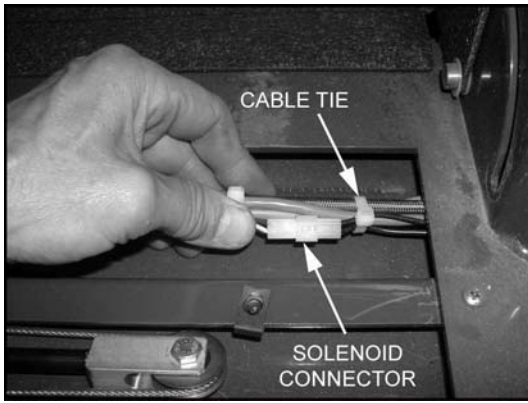

FIGURE 3-35

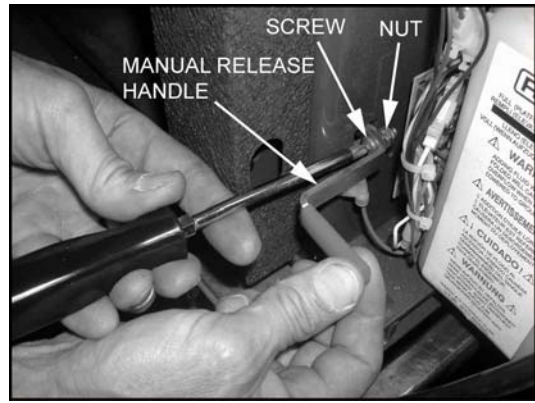

FIGURE 3-36

13. Refer to **Figure 3-37**. Remove two screws and two nuts to detach stow-lock assembly from tower assembly and retain hardware.

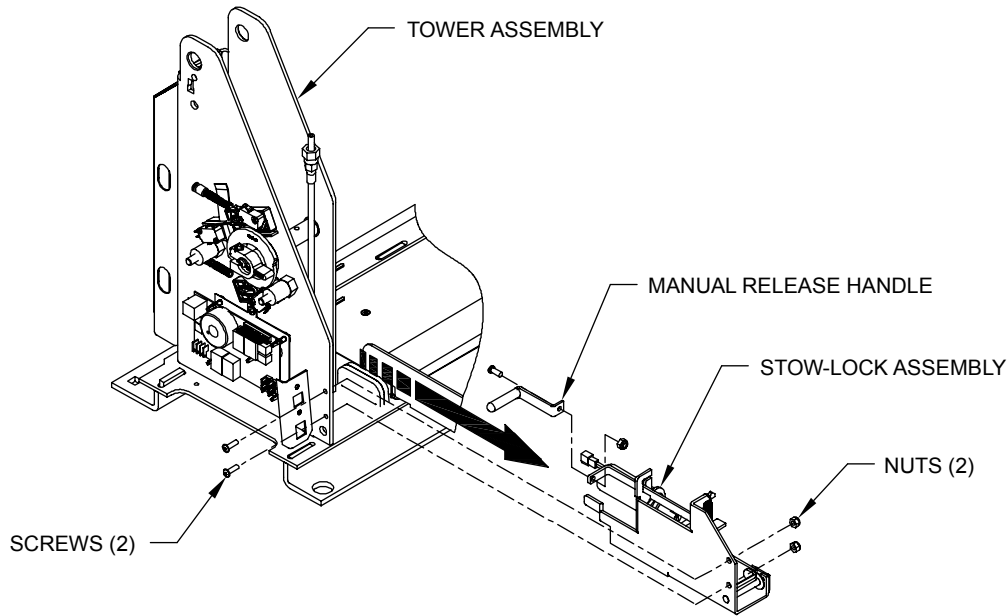

FIGURE 3-37

RSM0005900

14. Remove stow-lock assembly and replace with stow-lock assembly (P/N 35241). Re-assemble in reverse order.

I. T-NUT ROLLER REPLACEMENT

NOTE: T-Nut replacement procedure should be completed after Stow-Lock replacement. Platform will be deployed to ground level and knuckle arm assembly will be detached.

1. Refer to **Figures 3-38 and 3-39**. Remove snap ring then remove knuckle actuator pivot pin.

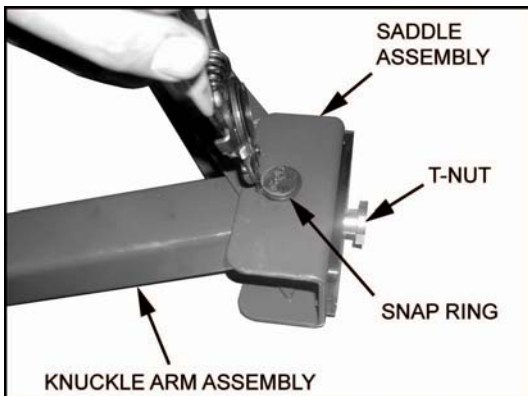

FIGURE 3-38

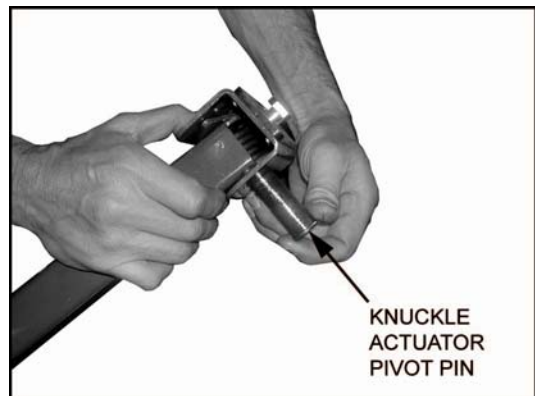

FIGURE 3-39

2. Refer to **Figure 3-40**. Unscrew and remove T-Nut from saddle assembly.

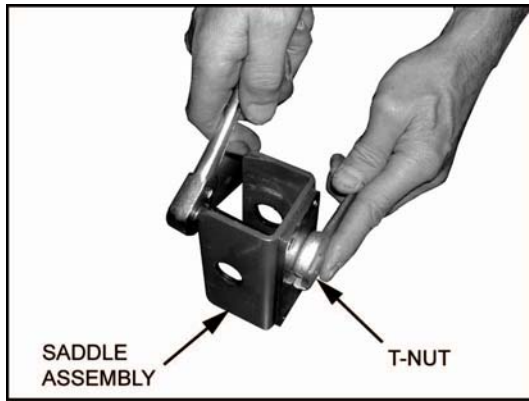

FIGURE 3-40

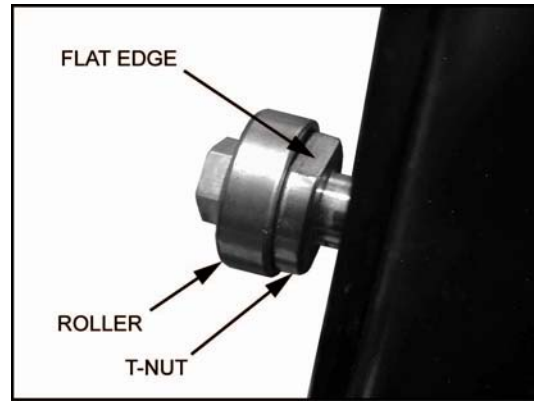

FIGURE 3-41

3. Replace old or worn T-Nut with Kit (P/N 42052).

NOTE: Before completing installation, ensure that T-Nut is oriented with the flat edge positioned in the horizontal position. Refer to **Figure 3-41**.

4. Check lower arm for burrs and sharp edges. De-burr or file sharp edges if necessary before re-assembly of saddle assembly.
5. Re-assemble in reverse order.

NOTE: Refer to **Figure 3-42**. Delrin guide blocks are factory installed. Ensure that each guide block is positioned towards the inside of the platform.

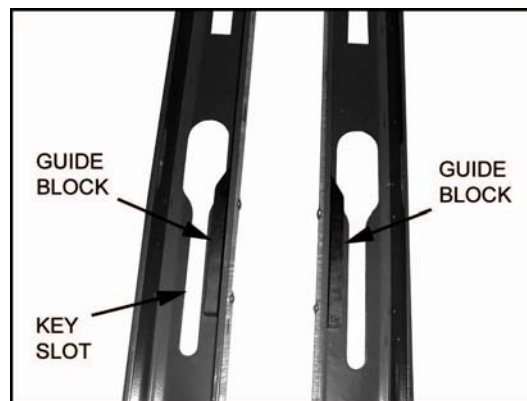

FIGURE 3-42

J. PUMP REPLACEMENT

⚠ CAUTION

This Ricon product is highly specialized. Maintenance and repairs must be performed by an authorized Ricon dealer or qualified service technician using Ricon replacement parts. Modifying or failing to properly maintain the product will void warranty and may result in unsafe operating conditions.

1. Disconnect power to lift.
2. Remove pump cover.
3. Lower lift to ground level with manual relief valve.

Note: Lowering lift to ground with manual relief valve will ensure that all pressure is relieved from the hydraulic system.

⚠ CAUTION

Wear safety glasses. Residual pressure may be in the hydraulic system, which can spray fluid when first loosening the fittings. Be prepared with rags to catch fluid that spills.

4. Refer to **Figure 3-43**. Disconnect two breather lines from pump only.

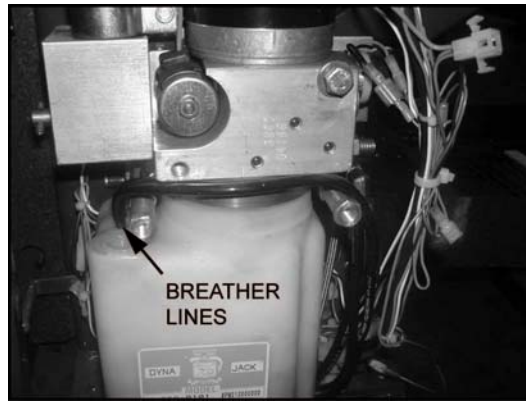

FIGURE 3-43

5. Refer to **Figure 3-44**. Disconnect hydraulic hoses from pump only.

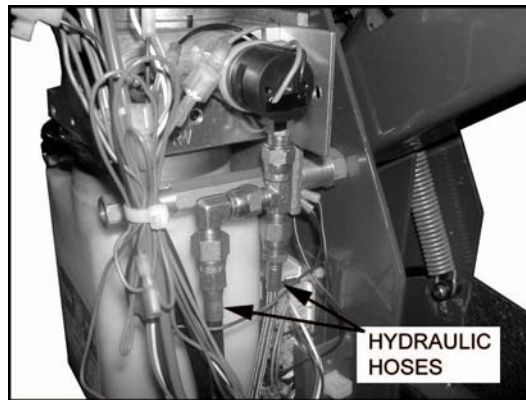

FIGURE 3-44

6. Refer to **Figure 3-45**. Disconnect electrical connections to pump.

Note: Mark and/or identify wires to ensure proper reconnection.

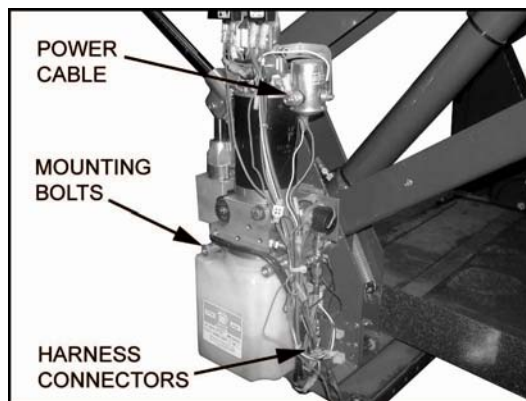

FIGURE 3-46

7. Refer to **Figure 3-47**. Remove two mounting bolts that mount pump to bracket. Retain for installation.
8. Lift pump out to be replaced with (PM312210112) pump assembly.
9. Re-assembly in reverse order.
10. Check fluid level and check for leaks.

Note: Platform pressure switch check and adjustment must be performed with 50lb. test procedure. Correct adjustment of this pressure switch is required to prevent platform from folding into vehicle when there is a load of 50lbs., or more, on platform. Refer to Chapter 2, Section C.5 for Platform Pressure Switch Check.

Note: Maximum hydraulic system pressure is factory set at 1100psi.

K. HYDRAULIC CIRCUIT DIAGRAM

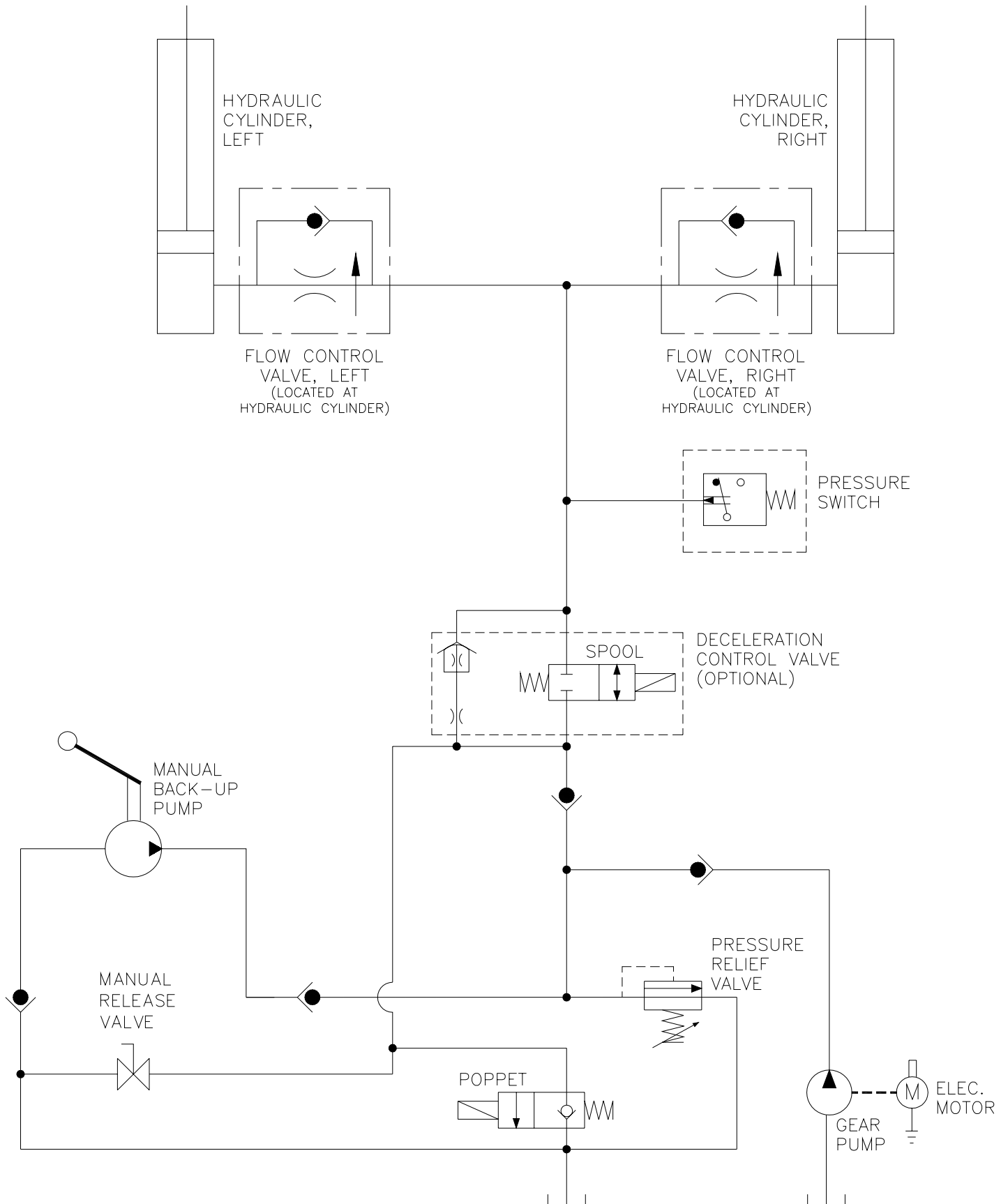

FIGURE 3-48: SLIDE-AWAY HYDRAULIC CIRCUIT DIAGRAM

L. ELECTRICAL WIRING DIAGRAM

1. DIAGRAM LEGENDS

a. Wire Color Codes

TABLE 3-3: WIRE COLOR CODES			
LETTER	COLOR	LETTER	COLOR
BK	Black	R	Red
BL	Blue	VI	Violet
BR	Brown	GY	Gray
GN	Green	W	White
O	Orange	Y	Yellow
END OF TABLE			

b. Electrical Connector Description

Refer to **Figure 3-49**. The typical electrical connector used by RICON is a .062" series. This connector has terminal numbers molded onto the back. Use these numbers and the wire colors to identify a terminal position within the connector.

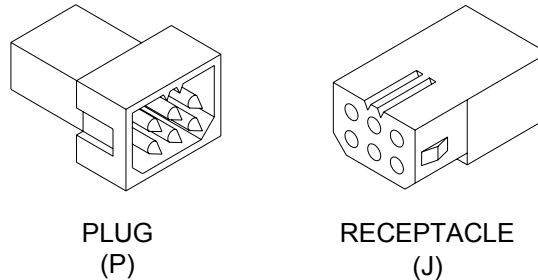

FIGURE 3-49: TYPICAL CONNECTOR

c. Diagram Labels

12V	12 Volts – Circuit current rating is also given
DC	Door Close – Direct command
DO	Door Open – Direct command
DOE	Door open Enable – From Door Open cutoff switch
DWN	Pump Down – Used by OUT and DWN
DWNA	Down Attempt – Must be enabled
FAST	Signal to speedup valve for UP and DOWN
GND	GROUND
OUTA	Out Attempt – Out must be enabled
SDA	System Deploy Attempt – DO followed by OUT
SSA	System Stow Attempt – IN followed by DC
UP	Pump Up – Used by UP and IN
UPA	Up Attempt – Up must be enabled

FIGURE 3-50: DIAGRAM LABELS

d. Electrical Symbols

Figure 3-51 defines the symbols used on the following electrical wiring diagram.

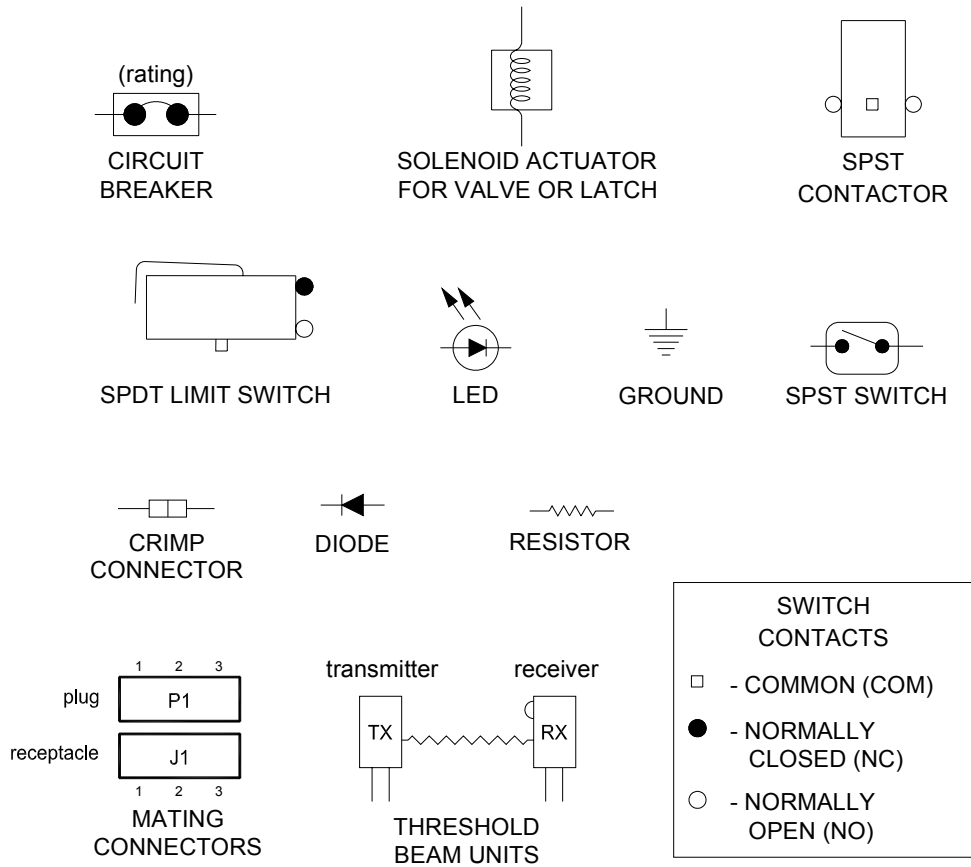

FIGURE 3-51: ELECTRICAL WIRING DIAGRAM SYMBOLS

2. WIRING DIAGRAM

Refer to **Figure 3-52 Sheets 1 and 2** on the following two pages.

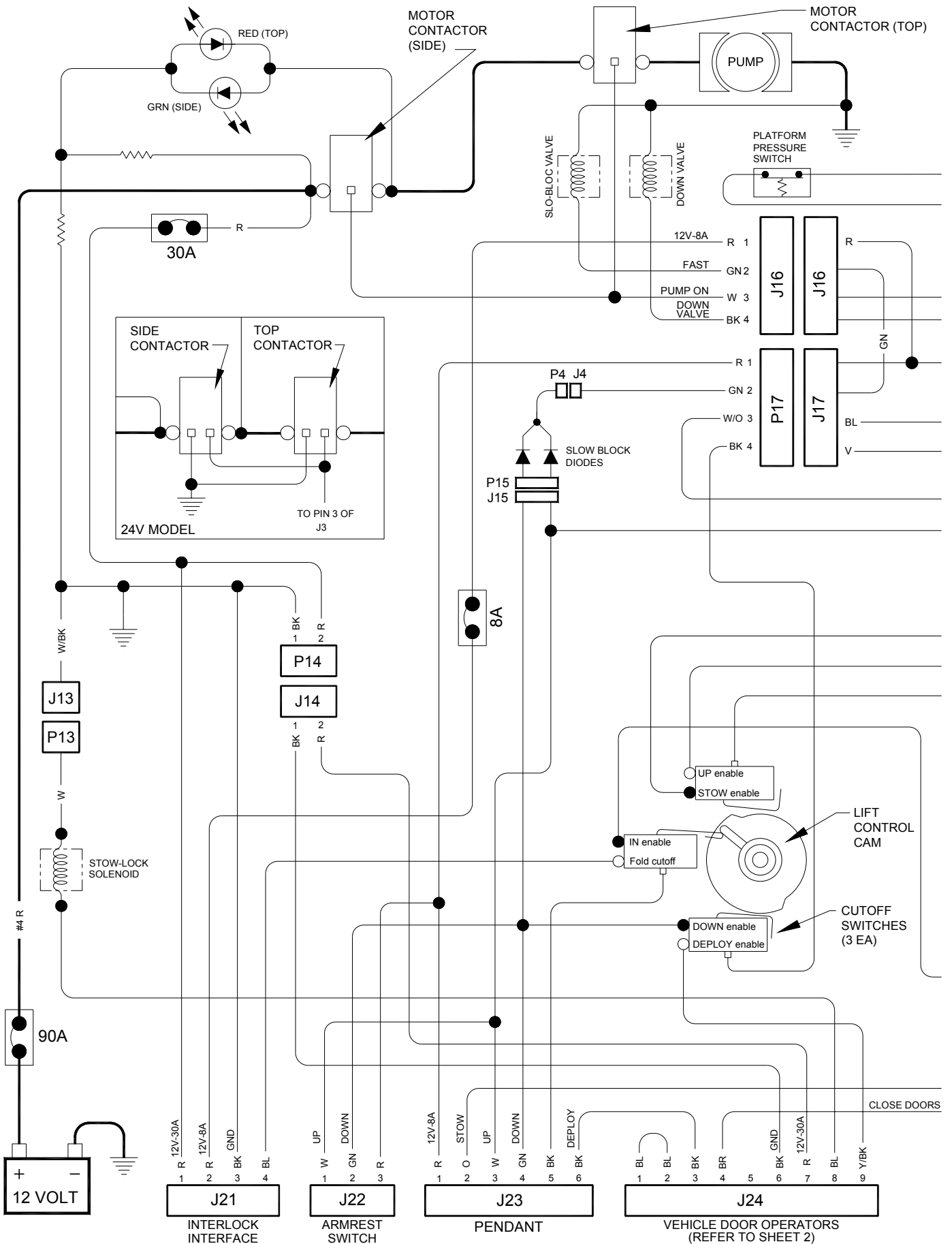

FIGURE 3-52: SLIDE-AWAY EXPORT USE LIFT SCHEMATIC – SHEET 1

IV. SLIDE-AWAY EXPORT USE SPARE PARTS

This chapter contains parts diagrams and lists for the Ricon Slide-Away® Export Use wheelchair lift. The exploded view of each major lift assembly shows individual components referenced by numbers. On each associated list are reference numbers, part descriptions, quantities used, and Ricon part numbers.

NOTE: To order a part, locate the part or assembly on an exploded view, note its reference number, find this number on the associated parts list (following page), and order the part number in the far right column. Most kits contain a single part (plus hardware). Therefore, you may need to order more than one kit if the part is used more than once on a major assembly.

NOTE: Small hardware and fasteners are supplied in bags of ten. The quantity listed is the number of bags needed for the assembly in the figure. In most cases the bag will contain more pieces than needed.

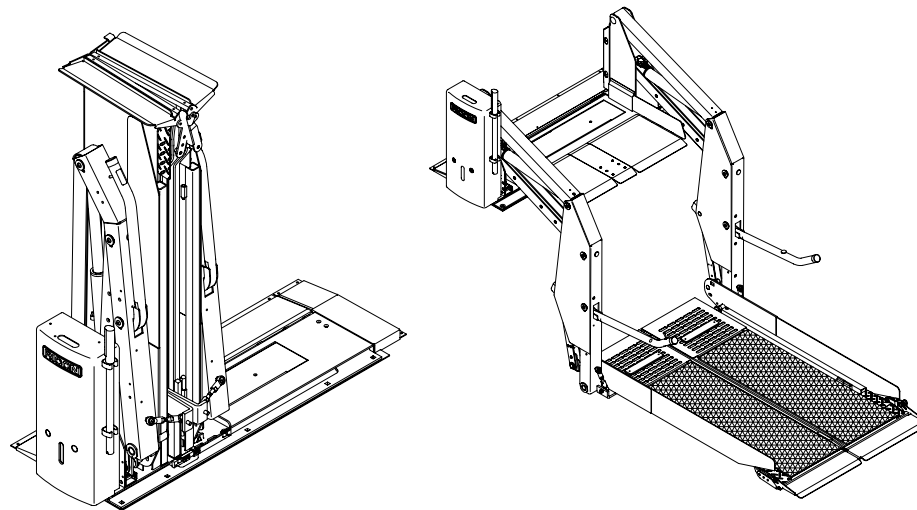

PARTS DIAGRAM	PAGE
FIGURE 4-1 SLIDE-AWAY DECAL LOCATION AND PART NUMBERS	4-2
FIGURE 4-2 SLIDE-AWAY PUMP ASSEMBLY	4-4
FIGURE 4-3 SLIDE-AWAY HYDRAULIC SYSTEM.....	4-6
FIGURE 4-4 SLIDE-AWAY ELECTRICAL SYSTEM	4-8
FIGURE 4-5 SLIDE-AWAY PENDANT & DOOR INTERLOCK SWITCH.....	4-10
FIGURE 4-6 SLIDE-AWAY PLATFORM ASSEMBLY	4-12
FIGURE 4-7 SLIDE-AWAY ARMS ASSEMBLY	4-14
FIGURE 4-8 SLIDE-AWAY BASEPLATE ASSEMBLY.....	4-16
FIGURE 4-9 SLIDE-AWAY ARMRESTS	4-18

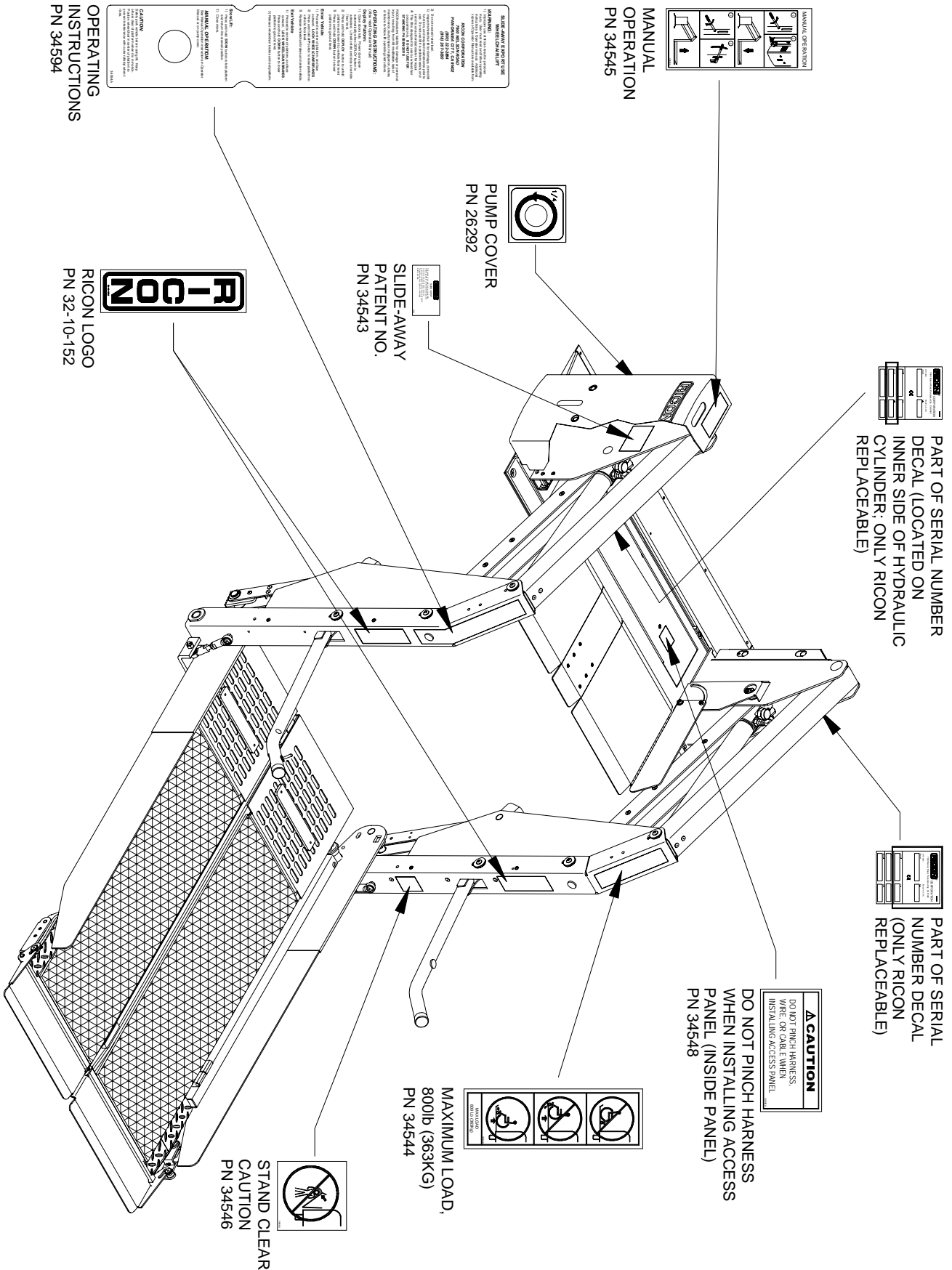

FIGURE 4-1: DECAL LOCATION AND PART NUMBERS

This page intentionally left blank.

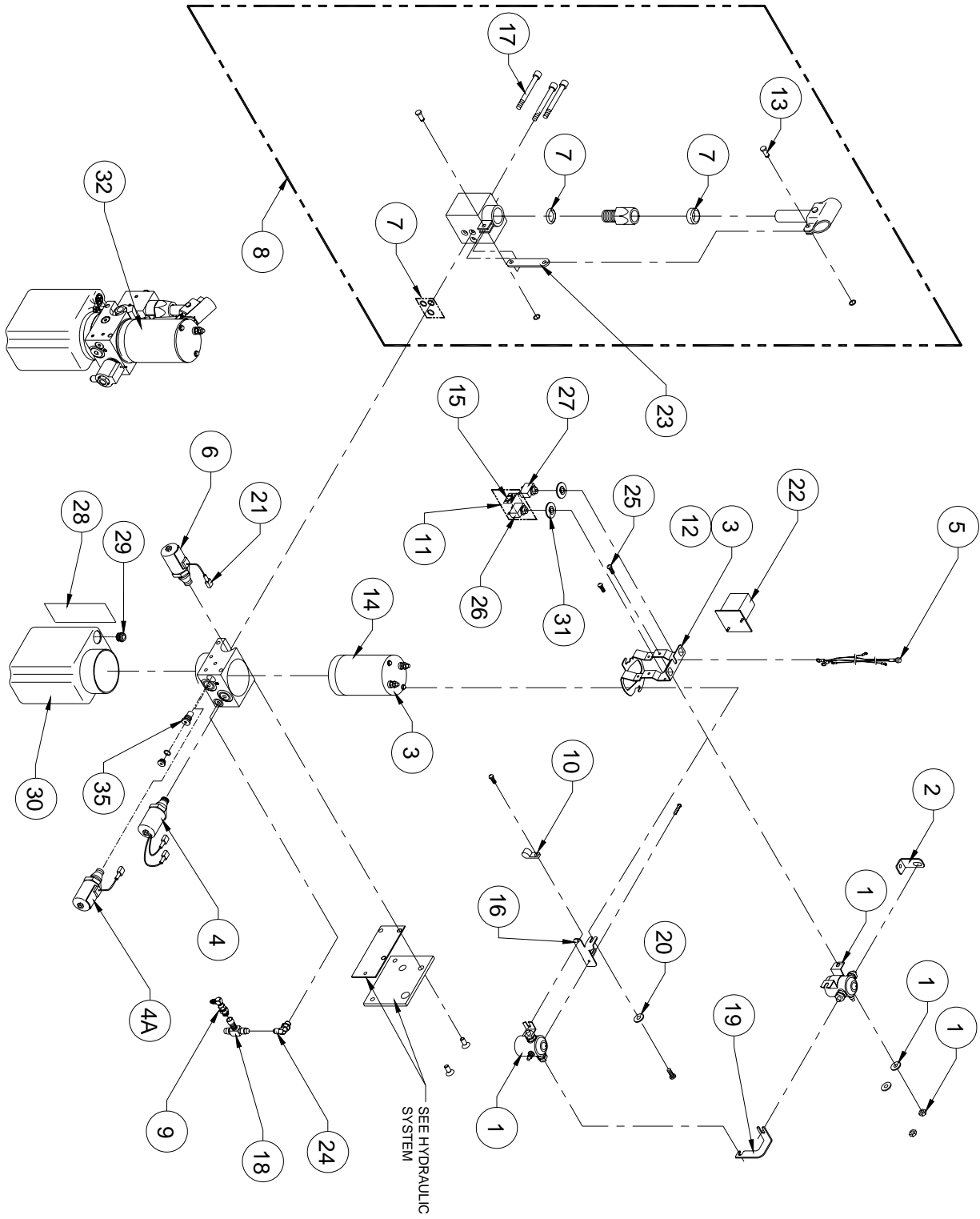

FIGURE 4-2: SLIDE-AWAY PUMP ASSEMBLY

FIGURE 4-2: SLIDE-AWAY PUMP ASSEMBLY

REF	DESCRIPTION	QTY	PART NO
1	KIT, SOLENOID, 12V. SPST	2	29297
2	BUS BAR, TOP SOLENOID	1	10807
3	MOTOR ASSEMBLY, WITH BRACKET, 12V	1	14345
4	SWITCH, HYDRAULIC PRESSURE, ADJUSTABLE*	1	15207
4A	SWITCH, HYDRAULIC PRESSURE, ADJUSTABLE***	1	39399
5	INDICATOR LIGHT ASSEMBLY, 12V	1	19067
6	DOWN VALVE ASSEMBLY, 12V	1	01176
7	KIT, SEAL, MANUAL BACK-UP PUMP	1	V2-SH-220
8	BACK-UP PUMP ASSEMBLY, MANUAL*	1	V2-SH-210
8A	BACK-UP PUMP ASSEMBLY, MANUAL (PM3)***	1	39390
9	FITTING ASSEMBLY, SNL, 1/4J X 1/4J, STEEL	1	VS-SH-06
10	CABLE CLAMP, 5/16", NYLON, BAG OF 10	1	19772
11	KIT, CIRCUIT BREAKER, 8 AMP, W/HDWR AND DECAL	1	V2-SH-005
12	BRACKET, MOTOR AND SOLENOIDS	1	10507
13	KIT, PIN AND RETAINING RING	2	V2-SH-017
14	KIT, PUMP MOTOR BRUSH SET (LOCATED INSIDE MOTOR)	1	14334
15	DECAL, 8 AMP CIRCUIT BREAKER	1	18797
16	BRACKET, SOLENOID	1	19036
17	SCREW, HEX RECESS, ¼-20 X 2.25L, BAG OF 10	1	32407
18	FITTING, SRT, 1/4J, STEEL	1	V2-SH-012
19	BUSBAR, SIDE SOLENOID	1	19042
20	WASHER, FLAT, .41 X .81 X .06, BAG OF 10	1	17510
21	TERMINAL, SLIP, M22-18 FULL INSUL, BAG OF 10	1	29388
22	COUNTER ASSEMBLY	1	33048
23	BRACKET, TENSION LINK, MANUAL PUMP	1	V2-SH-149
24	FITTING, ELBOW, #4STD X #4JIC	1	18235
25	SCREW, PAN HEAD, 10-24 X ½, BAG OF 10	1	13304
26	CIRCUIT BREAKER, 8 AMP	1	265108
27	CIRCUIT BREAKER, 10 AMP	1	26510
28	DECAL, OIL LEVEL WARNING	1	32-10-154
29	BREATHING PLUG, RESERVOIR	1	10333
30	RESERVOIR, HYDRAULIC PUMP	1	30938
31	ADAPTER, .63 D-HOLE-TO-.48 ROUND	2	V2-ES-059
32	HYDRAULIC PUMP ASSEMBLY, 12VDC, FRAME GROUND	1	PM312210112
33	HARNESS, PUMP, 12V AND 24V**	1	V2-ES-100
34	HARNESS, PUMP INTERFACE**	1	33077
35	CHECK VALVE, CARTRIDGE, PUMP (PM3)	1	39389

*** Part # 39399, 39390 apply to serial numbers 220911 and later.

** Item(s) not shown.

* Part # 15207, V2-SH-210 apply to serial numbers 201868 thru 220910.

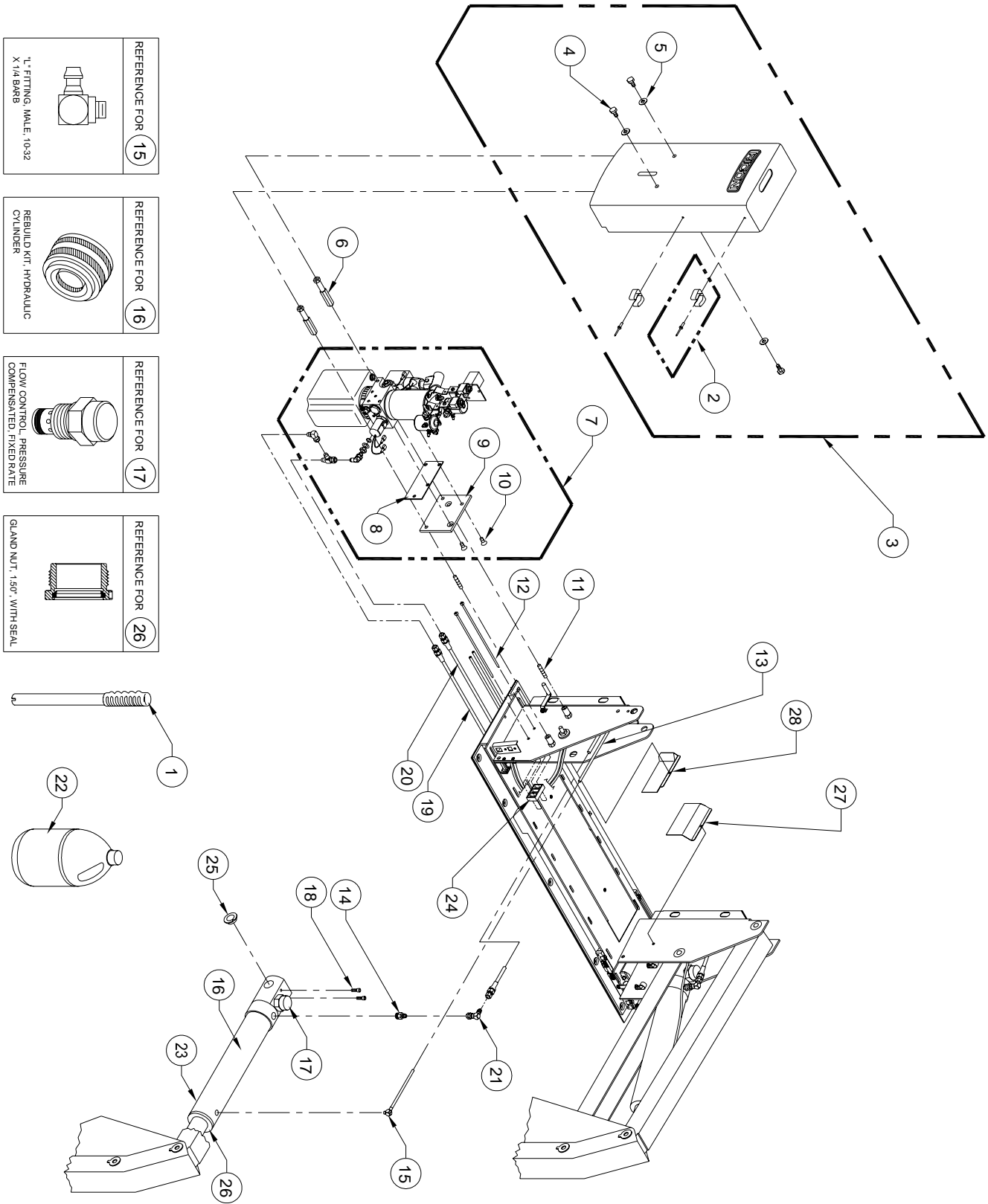

REFERENCE FOR (15)
 T-FITTING, MALE, 1/0-3/2
 X 1/4 BARB

REFERENCE FOR (16)
 REBUILD KIT, HYDRAULIC
 CYLINDER

REFERENCE FOR (17)
 FLOW CONTROL, PRESSURE
 COMPENSATED, FIXED RATE

REFERENCE FOR (26)
 GLAND NUT, 1.50", WITH SEAL

FIGURE 4-3: SLIDE-AWAY HYDRAULIC SYSTEM

FIGURE 4-3: SLIDE-AWAY HYDRAULIC SYSTEM

REF	DESCRIPTION	QTY	PART NO
1	HANDLE, MANUAL BACKUP PUMP	1	V2-SH-111
2	KIT, TOOL CLIP, W/HDWR	2	19557
3	COVER ASSEMBLY, PUMP, LH	1	V2-CV-200
4	SCREW, HEX HEAD, 5/16-18 X .62, BAG OF 10	1	14495
5	WASHER, FLAT, 5/16", BAG OF 10	1	13350
6	HEX ROD, PUMP STANDOFF	2	V2-CV-015
7	PUMP ASSEMBLY, 12V, LH (SUPERSEDED: SEE 7A)	1	PM212210100
7A	PUMP ASSEMBLY, 12V, LH**	1	PM312210112
8	PLATE, PUMP COVER MOUNT	1	V2-AC-71
9	PLATE, PUMP MOUNT	1	V2-AC-70
10	SCREW, FLAT HEAD, 5/16-18 X 3/4", BAG OF 10	1	14499
11	STUD, THREADED, 5/16-18 X 1.75", BAG OF 10	1	14500
12	CABLE TIE, 5.5", BLACK, BAG OF 10	1	25697
13	TUBE, POLYURETHANE, 6MM X 4MM, BLACK	9	22-02-230
14	ADAPTOR, #6 SAE MALE X #4 JIC MALE	2	26591
15	FITTING, "L", MALE 10-32 X 1/4" BARB	2	V2-SH-16
16	KIT, CYL REPAIR, (SUPERSEDED: SEE 26A)	2	V2-SH-56
17	KIT, FLOW CONTROL, FIXED RATE .50 GPM, KIT OF 2	1	30968
18	SCREW, HEX RECESS, 1/4-20 X 1, BAG OF 10	1	14491
19	HOSE ASSEMBLY, 86" X 1/4JIC X 1/8ID	1	35295
20	HOSE ASSEMBLY, HYDRAULIC, 26" X 1/4 JIC X 1/4 JIC	1	V2-SH-008
21	FITTING, "L", 1/4 JIC M-F SWIVEL	2	VS-SH-06
22	OIL, HYDRAULIC, TEXACO #5, MEETS MIL-H-5606G	1 GAL	20-16-051
23	CYLINDER ASSEMBLY (SUPERSEDED: SEE 23A)	2	VS-SH-105
23A	CYLINDER ASSEMBLY	2	VS-SH-105K
24	SPACER, CABLE AND HOSE	2	25557
25	BUSHING, 3/4" ID X 3/8 W	4	25386
26	GLAND NUT, 1.50", WITH SEAL (SUPERSEDED: SEE 26A)	2	13009
26A	KIT, CYL REPAIR (PISTON/GLAND ASSY, W/INSTR)	2	21829
27	COVER, GAS SPRING, RH	1	39366
28	COVER, GAS SPRING, LH	1	39364

**Refer to Pump Assembly figure for parts breakdown.

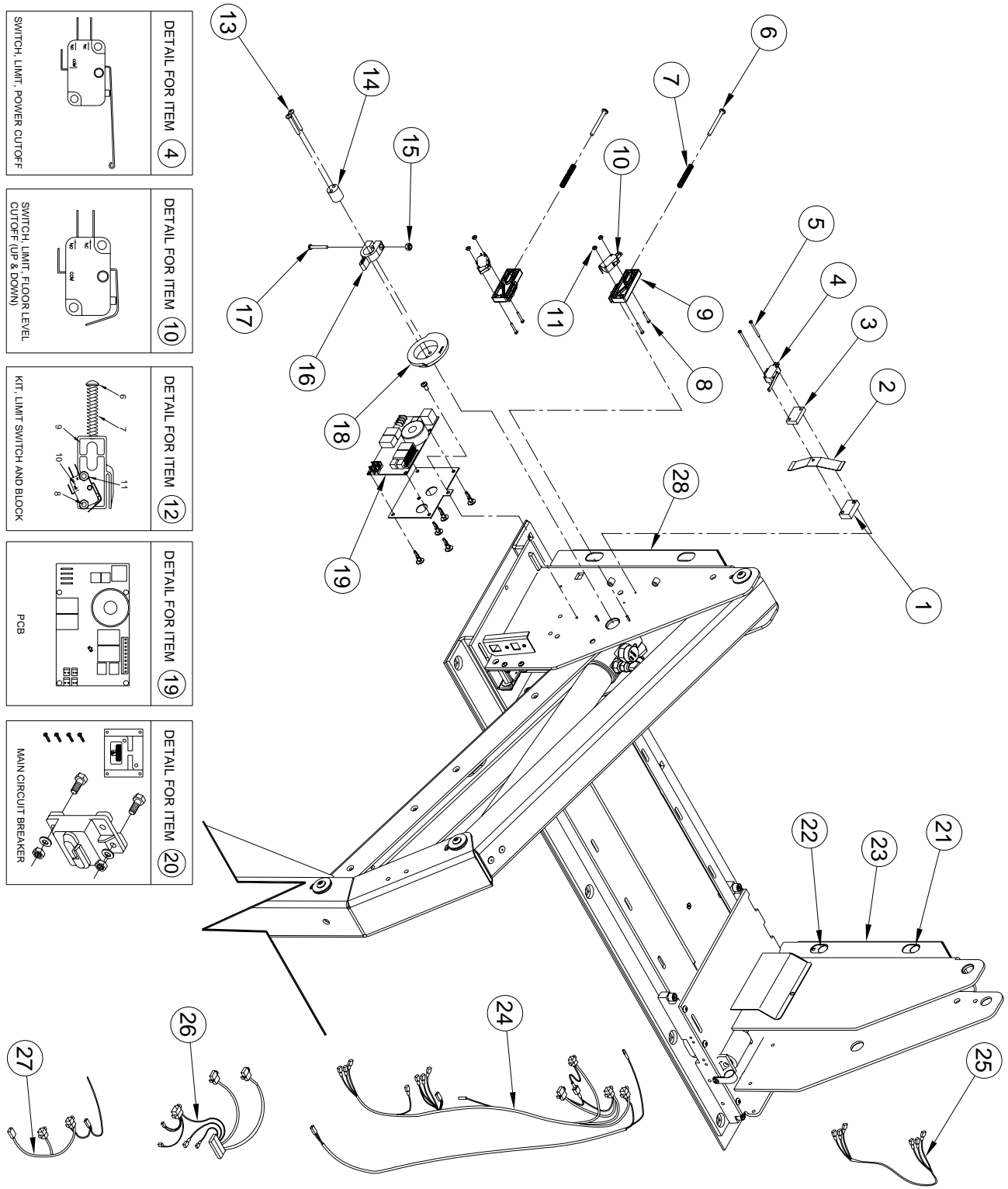

FIGURE 4-4: SLIDE-AWAY ELECTRICAL COMPONENTS

FIGURE 4-4: SLIDE-AWAY ELECTRICAL SYSTEM

REF	DESCRIPTION	QTY	PART NO
1	BLOCK, FOLD CUTOFF SWITCH, 3/8" THICK	1	V2-ES-79
2	SPRING RETAINING, 3/4 x 4	1	V2-ES-95
3	BLOCK, FOLD CUTOFF SWITCH, 1/4" THICK	1	V2-ES-78
4	SWITCH, LIMIT	1	V2-ES-111
5	SCREW, PAN HEAD, 4-40 X 1-1/4, BAG OF 10	1	15908
6	SCREW, ROUND HEAD, 10-24 X 2, BAG OF 10	1	14497
7	SPRING, COMPRESSION, .30OD X 2.06L	2	V2-ES-93
8	SCREW, PAN HEAD, 4-40 X .75, BAG OF 10	1	15909
9	SWITCH BLOCK	2	34314
10	SWITCH, LIMIT, CUT OFF	2	V2-ES-110
11	NUT, HEX, 4-40, BAG OF 10	1	15903
12	KIT, LIMIT SWITCH AND BLOCK	2	V2-ES-61
13	SCREW, PAN HEAD, 10-24 X 1-3/4, BAG OF 10	1	29318
14	PIN, EXTENSION, BAG OF 10	1	15914
15	NUT, ESN, 10-24, BAG OF 10	1	13382
16	ACTUATOR, CAM	1	V2-AC-089
17	SCREW, PAN HEAD, 8-32 X 1-1/4, BAG OF 10	1	15906
18	CAM, LIMIT SWITCH	1	V2-AC-107
19	PCB ASSEMBLY	1	33057
20	KIT, CIRCUIT BREAKER, MAIN, 90A	1	01010K
21	SENSOR, PHOTOBEAM, RECEIVER	2	32499
22	SENSOR, PHOTOBEAM, TRANSMITTER	2	32498
23	SENSOR ASSEMBLY, RH, TWS	1	36204
24	HARNESS, MAIN ELECTRIC	1	33073
25	HARNESS, MOVING TOWER	1	32796
26	HARNESS, PCB, CAM SWITCH INTERFACE	1	33030
27	HARNESS, PCB, POWER INTERFACE	1	33031
28	SENSOR ASSEMBLY, LH, TWS	1	36205

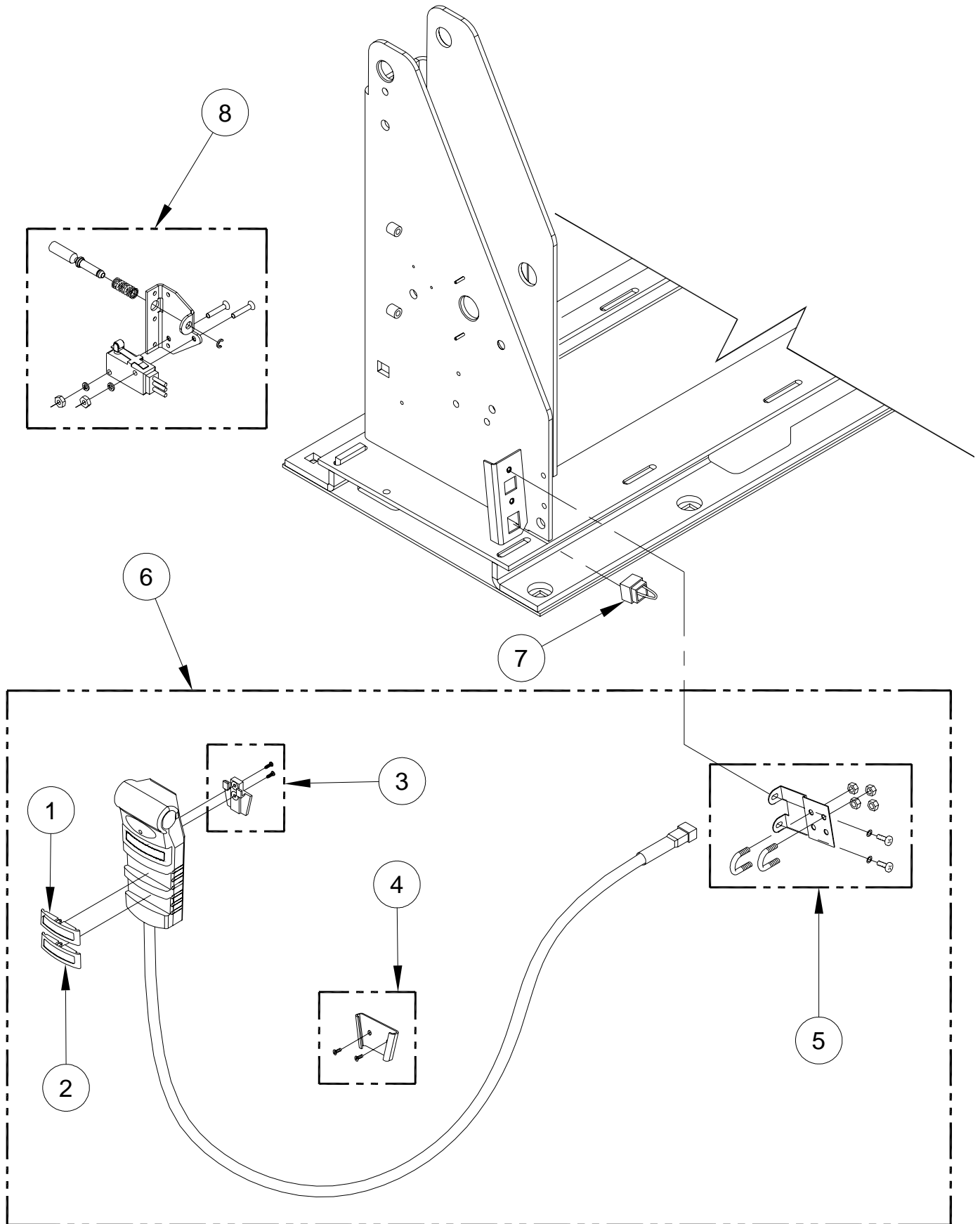

FIGURE 4-5: SLIDE-AWAY PENDANT AND DOOR INTERLOCK SWITCH

FIGURE 4-5: SLIDE-AWAY PENDANT & DOOR INTERLOCK SWITCH

REF	DESCRIPTION	QTY	PART NO
1	STOW and DEPLOY BUTTON	1	UL-ES-007
2	UP and DOWN BUTTON	1	14731
3	V-BRACKET, PLASTIC, W/HDWR	1	14732
4	KIT, WALL MOUNT BRACKET, UNIVERSAL PENDANT	1	14733
5	KIT, CONTROL HARNESS STRAIN RELIEF	1	14709
6	KIT, PENDANT, 7FT	1	01007
7	SHORTING PLUG	1	UL-ES-007
8	SWITCH ASSEMBLY, DOOR INTERLOCK	1	35956

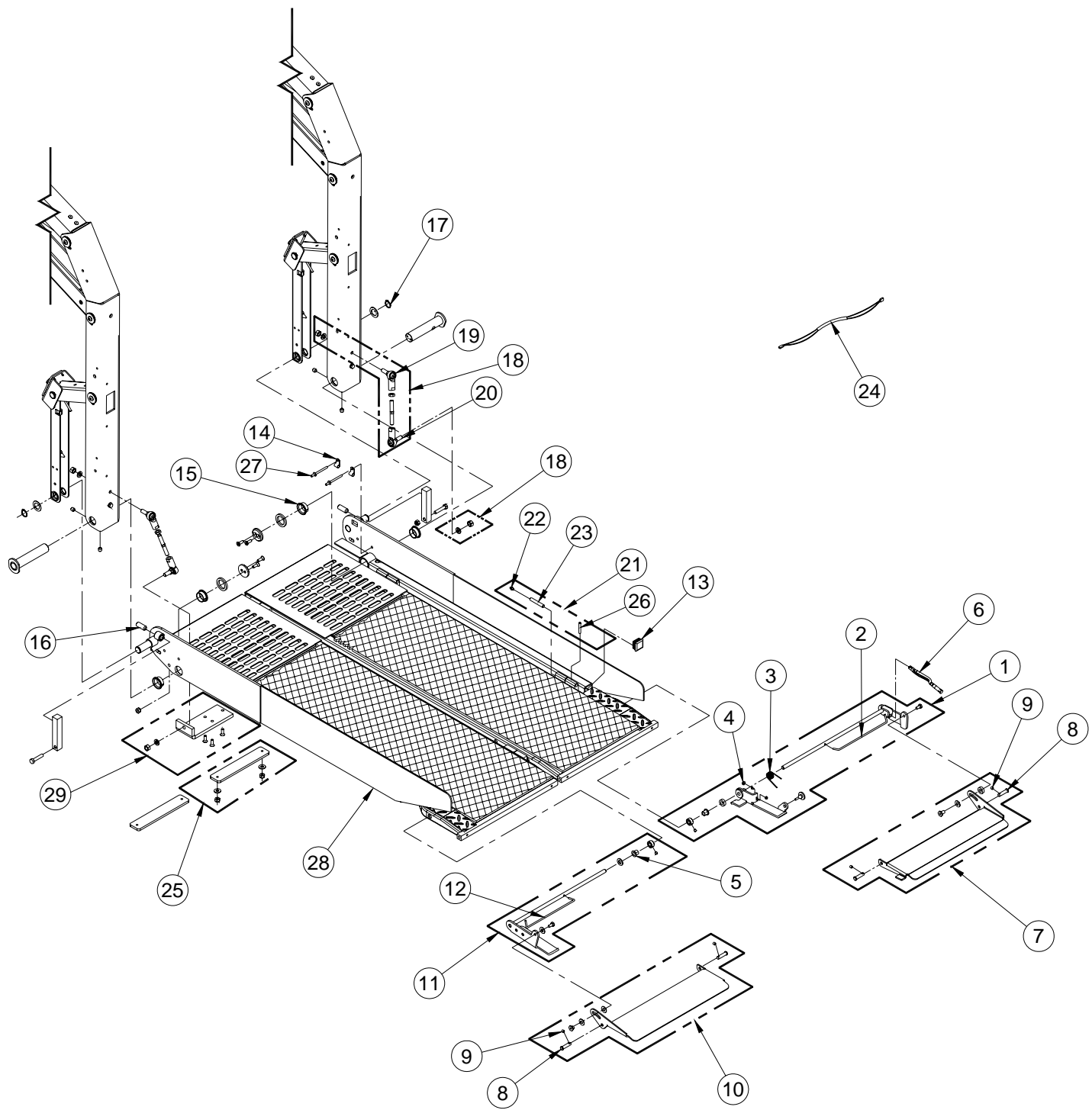

FIGURE 4-6: SLIDE-AWAY PLATFORM ASSEMBLY

FIGURE 4-6: SLIDE-AWAY PLATFORM ASSEMBLY

REF	DESCRIPTION	QTY	PART NO
1	KIT, ROLLSTOP ACTUATOR, RH, W/HDWR	1	34578
2	SPRING, TORSION, RH	1	V3-SP-22
3	SPRING, ROLLSTOP ACTUATOR	1	30589
4	MAGNET, FLAT HEAD RECESS	1	MM-400
5	BUSHING, .392 ID, BRONZE	2	V2-BU-195
6	SENSOR ASSEMBLY, ROLLSTOP	1	32755
7	KIT, ROLLSTOP, RH, W/HDWR	1	34579
8	PIN, CLEVIS, 5/16 X 1-1/4, BAG OF 10	1	19513
9	SETSCREW, CONE POINT, 1/4-20 X1/4, BAG OF 10	1	14492
10	KIT, ROLLSTOP, LH, W/HDWR	1	34580
11	KIT, ROLLSTOP ACTUATOR, LH, W/HDWR	1	34581
12	TORSION BAR, LH	1	V3-SP-21
13	PLUG, BLACK	2	10258
14	CLAMP, CABLE 3/8", BAG OF 10	1	32408
15	FLANGE BEARING, 1" ID, KIT OF 10	1	19579
16	SETSCREW, 1/2-20X1-1/4L, NYLOK, BAG OF 10	1	19704
17	SNAP RING, 3/4, BAG OF 10	1	11796
18	KIT, TIE-ROD ASSEMBLY	2	34582
19	ROD END, 3/8-24,RH THREAD	2	35209
20	ROD END, 3/8-24. LH THREAD	2	35249
21	KIT, PLATFORM HINGE PARTS	6	34583
22	GREASE FITTING, 3/16X.50 LONG, KIT OF 6	1	34584
23	PIN, .31 OD X 2.00, SST, KIT OF 6	1	34585
24	HARNESS, ROLLSTOP SWITCH	1	32798
25	KIT, PLATE, WHEELCHAIR LOCATION, W-HDWR	2	34590
26	ROLLPIN, 5/32 X 1/ 1/4 SST, BAG OF 10	1	14465
27	RIVET, PEEL, 3/16 X .590	4	37150
28A	PLATFORM ASSEMBLY, 30" X 42"	1	34608
28B	PLATFORM ASSEMBLY, 30" X 48"	1	35272
29	KIT, ROD-END BRACKET W/HDWR	1	36964

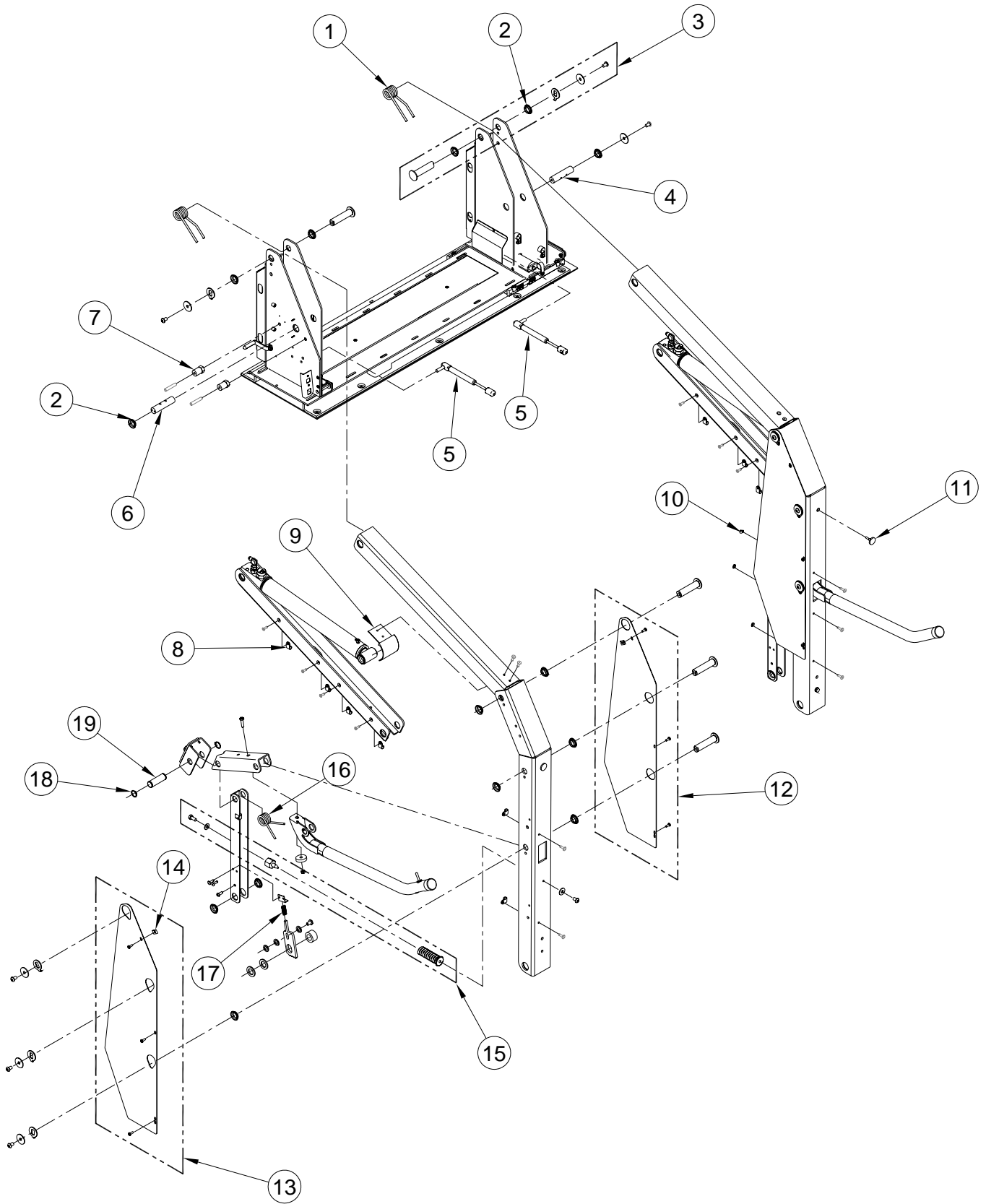

FIGURE 4-7: SLIDE-AWAY ARM ASSEMBLIES

FIGURE 4-7: SLIDE-AWAY ARM ASSEMBLIES

REF	DESCRIPTION	QTY	PART NO
1	SPRING, TORSION, TOP ARM	2	V2-SP-97
2	FLANGE BEARING, ¾ ID, KIT OF 10	2	19576
3	KIT, PIN, LINK ARM, W/HDWR	8	34586
4	PIN, LOWER ARM	1	V2-PI-097
5	SPRING, EXTERNAL, .75OD X .085W X 4"L, SST (OBSOLETE: SEE 5A)	2	34687
5A	SPRING, PNEUMATIC	2	39939
6	PIN, LOWER ARM, CAM	1	V2-PI-091
7	BUSHING, PUMP MOUNT	2	V2-BU-081
8	CLAMP, NYLON, 5/16", BLACK, BAG OF 10	1	19772
9	CAP, UPPER PARALLEL ARM, PLASTIC	2	V2-AC-89
10	CLAMP, 3/16" NYLON, BLACK, BAG OF 10	1	19798
11	BUMPER, RUBBER, KIT OF 2	1	20653
12	KIT, PINCH POINT SHIELD, W/HDWR, RH	2	34587
13	KIT, PINCH POINT SHIELD, W/HDWR, LH	2	34588
14	SPRING NUT, 10-24, U-TYPE, BAG OF 10	1	11799
15	KIT, SPRING, KICKOUT	1	01115
16	SPRING, TORSION, KNUCKLE ACTUATOR	1	VT-SP-42
17	SPRING, COMPRESSION .468OD X 1-1/4L	1	UV-SP-009
18	SNAP RING, ¾, BAG OF 10	1	11796
19	PIN, PIVOT, KNUCKLE ACTUATOR	2	VT-PI-41

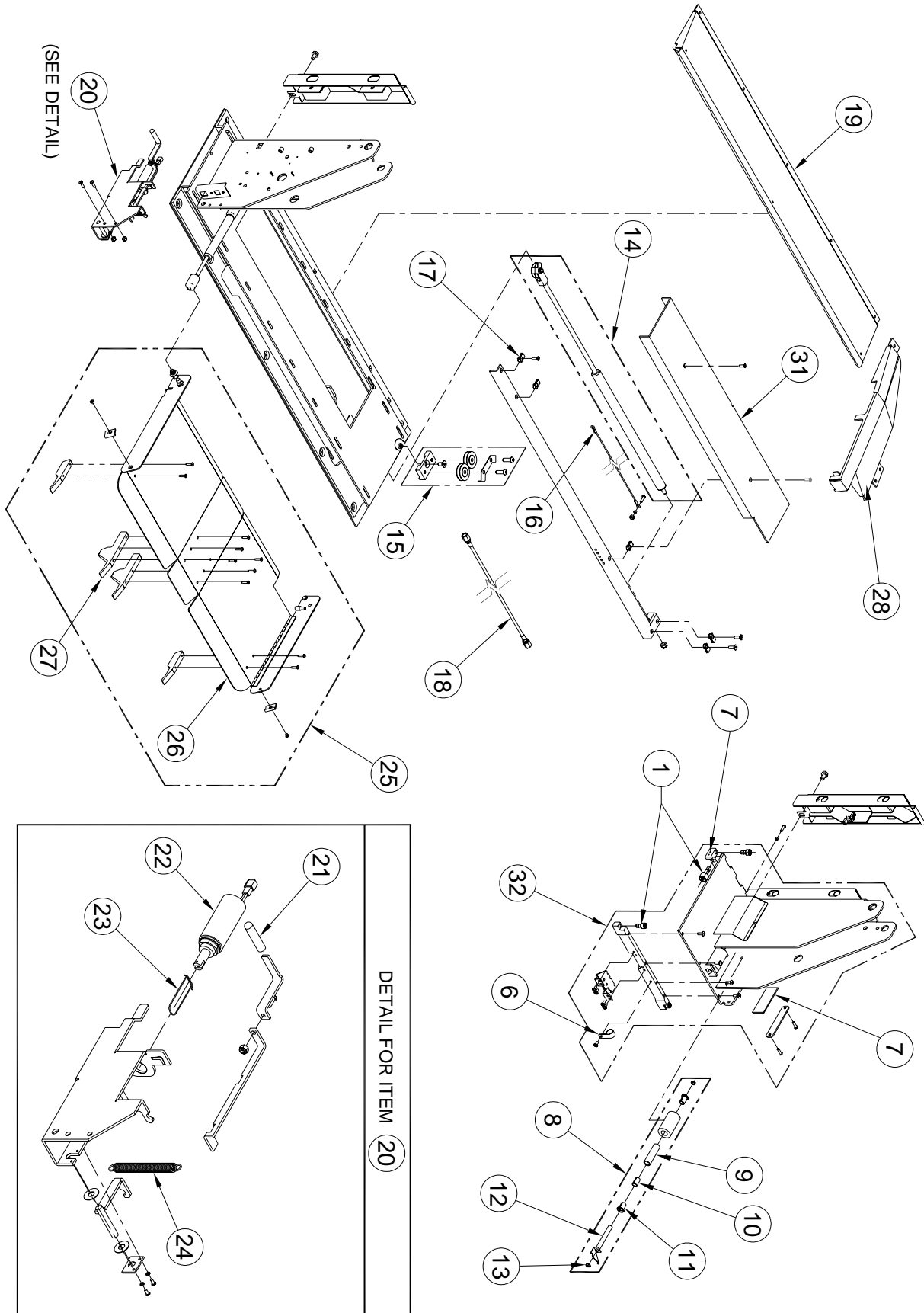

FIGURE 4-8: SLIDE-AWAY BASEPLATE ASSEMBLY

FIGURE 4-8: SLIDE-AWAY BASEPLATE ASSEMBLY

REF	DESCRIPTION	QTY	PART NO
1	KIT, TOWER CAM FOLLOWERS, W/HDWR***	1	36960
1A	KIT, TOWER ROLLERS AND GUIDE, W/HDWR** not shown	2	34573
1B	KIT, TOWER ROLLERS, W/HDWR* not shown	4	34572
2	GUIDE, BLOCK** not shown (INACTIVE: SEE 32A)	1	35950
3	ROLLER, SIDE** not shown (INACTIVE: SEE 32A)	2	35227
4	BEARING** not shown (INACTIVE: SEE 32A)	2	24919
5	SLEEVE BUSHING** not shown (INACTIVE: SEE 32A)	8	33987
6	CLAMP, ½" ID, VINYL	1	34560
7	KIT, WIPERS	1	36963
8	KIT, MAIN ROLLER ASSEMBLY, W/HDWR	1	34574
9	SLEEVE, BEARING SUPPORT	1	36220
10	BEARING, NO FLANGE, 3/8ID X ¾ LONG	1	34610
11	BEARING, FLANGED, 3/8ID X ¾ LONG, KIT OF 2	1	34575
12	PIN, 37"OD x 3"L	1	34685
12A	WELDMENT, PIN MAIN ROLLER	1	42804
13	SNAP RING, 3/8, BAG OF 10	1	11795
14	GAS SPRING ASSEMBLY (SEE KIT 14A)	1	35282
14A	KIT, GAS SPRING	1	36998
15	PULLEY, W/BEARING (SEE KIT 15A)	2	VS-AH-06
15A	KIT, DUAL PULLEY	2	42059
16	CABLE, SST, 3/32 X 60.0L, .40 EYES (SEE KIT 14A)	1	35233
17	SPRING NUT, 10-24, BAG OF 10	1	25348
18	HOSE ASSEMBLY, 86" X 1/4JIC X 1/8ID	1	35295
19	RAMP, THRESHOLD, REAR	1	39300
19A	RAMP, REAR, BASEPLATE**shown	1	35281
20	STOW LOCK ASSEMBLY	1	35241
21	CAP, .31 X 1.5, "RICON"	1	01651
22	SOLENOID ASSEMBLY, 12V	1	10019
23	CLIP, SPRING, SST	1	V2-AC-009
24	SPRING, 3.75L X .38OD	1	V2-SP-093
25	KIT, BRIDGEPLATE ASSEMBLY, W/HDWR (INACTIVE: SEE KIT 25A)	1	34577
25A	KIT, BRIDGEPLATE ASSEMBLY, W/HDWR	1	36967
26	BRIDGEPLATE (INACTIVE: SEE 26A)	1	34641
26A	BRIDGEPLATE WLDT, SLIDER	1	39334
27	SLIDER, BRIDGEPLATE (SEE KIT 27A)	1	34648
27A	KIT, GUIDE, BLOCK, BRIDGEPLATE	1	42061
28	RAMP, SIDE, BASEPLATE (DISCONTINUED)	1	33999
29	SHIELD, PULLEY (SEE KIT 15A)	1	35958

(CONTINUED)

FIGURE 4-8: SLIDE-AWAY BASEPLATE ASSEMBLY (CONTINUED)

REF	DESCRIPTION	QTY	PART NO
30	COVER, GUARDRAIL	1	37100
31	COVER, ACCESS (DISCONTINUED: SEE 31A)	1	34681
31A	COVER, ACCESS, BASEPLATE, SLIDER	1	39303
32	KIT, SLIDING TOWER WLDT W/ATTACHMENTS (INACTIVE: SEE 32A)	1	36926
32A	KIT, GUIDE, ANCHOR, TOWER,SLIDE AWAY	1	42057

*** Part # 36960 applies to serial numbers 220911 and later.

** Part # 34573, 35950, 35227, 24919, 33987, 36926 apply to serial numbers 201868 thru 220910.

* Part # 34572 applies to serial numbers 199306 thru 201867.

This page intentionally left blank.

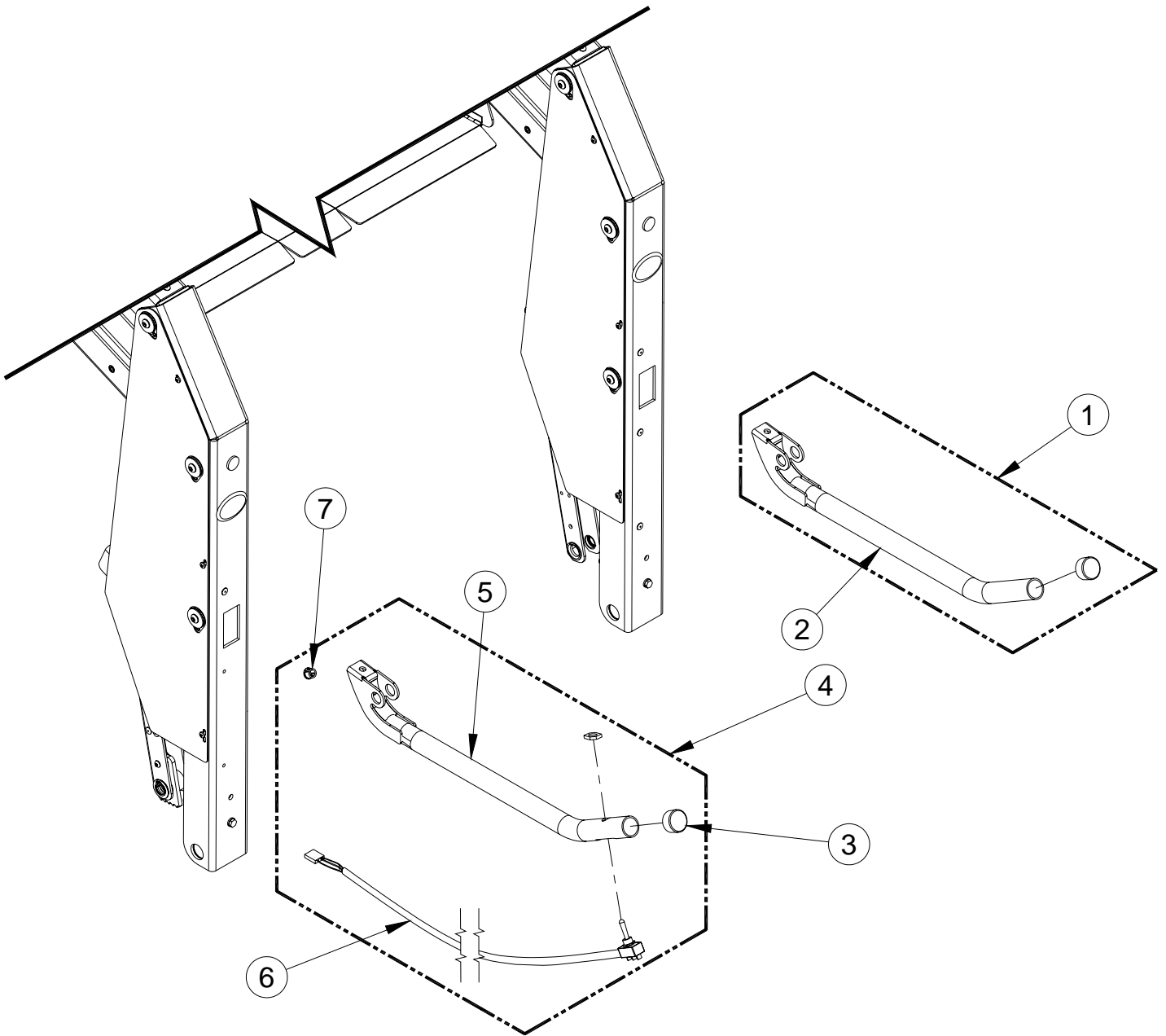

FIGURE 4-9: SLIDE-AWAY ARMRESTS

FIGURE 4-9: SLIDE-AWAY ARMRESTS

REF	DESCRIPTION	QTY	PART NO
1	ARMREST ASSEMBLY, RH	1	VS-AC-159
2	ARMREST, RH	1	VS-AC-181
3	CAP, BLACK	2	25550
4	ARMREST ASSEMBLY, LH, W/HARNESS	1	VS-AC-160
5	ARMREST, LH	1	VS-AC-182
6	HARNESS, W/ARM SWITCH	1	V2-ES-012
7	BUSHING, SNAP-IN	1	28-26-077

APPENDIX 1 LIFT SPECIFICATIONS

SLIDE-AWAY EXPORT USE PLATFORM LIFT

Power..... electro-hydraulic
 Motor rating @ 12 volts DC 65.0 amp. avg/cycle, 8619kPa
 Hydraulic cylinders 2 ea, 38mm, power-up/gravity-down

Rated load capacity 363kg
 Manual backup (up)..... hand pump
 Manual backup (down) pressure release valve
 Lift weight..... 163-177kg

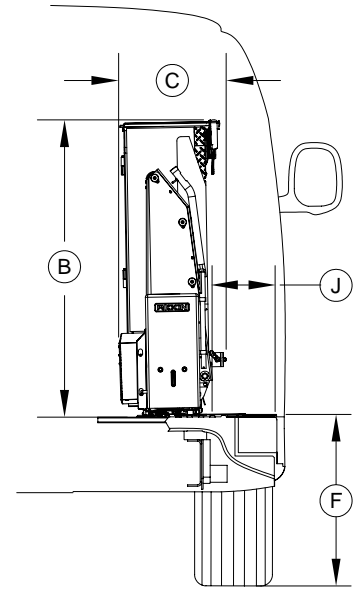
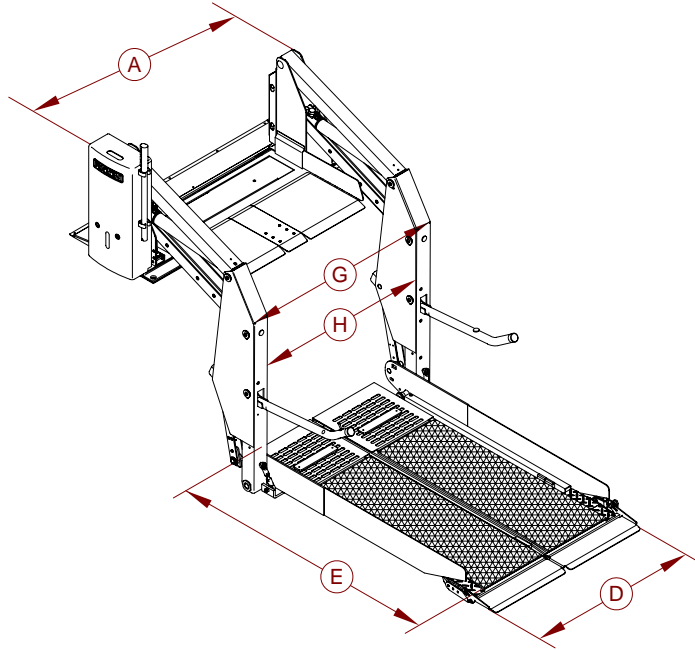

DIMENSIONS (millimeters)

MODEL	A	B	C	D	E	F	G	H	*I	**J
	Stationary frame width	Height (folded)	Installation depth (folded)	Usable platform width	Usable platform length	Floor-to-ground travel	Traveling frame width	Clear entry width	Stowed arms width	Installed depth
ST00	1143	1168	546	762	1067	762	953	787	489 (max)	178
ST01	1143	1321	546	762	1219	762	953	787	489 (max)	178

END OF TABLE

*Item "I" is not shown.

**Measurement for item "J" is taken from front edge of baseplate to door sill.

This page intentionally left blank.

