

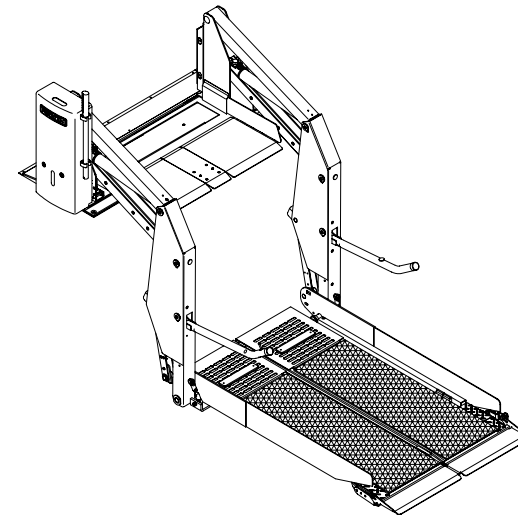

SLIDE-AWAY[®]
Export Use
Wheelchair and Standee Lift

-PRINT -



Operator Manual



02-24-11

32DSW03.C.1

-HOME -

©2011 RICON CORPORATION
All Rights Reserved

U.S. Patent Nos: 4,534,450; 5,308,215; 5,445,488; 5,605,431; 5,944,473
Australian Patent No: 687,066 Canadian Patent No: 1,245,603
Other U.S. and foreign patents pending.
Printed in the United States of America

This RICON product must be installed and serviced by RICON authorized dealers.

The owner must refer to this manual for operating instructions, then retain it for future reference by RICON authorized dealers that perform maintenance.

©2011 RICON CORPORATION

All Rights Reserved

U.S. and Foreign Patents Pending

Printed in the United States of America

Customer Information	
Customer name	
Installing dealer	
Date installed	
Serial number	

REVISION RECORD

REVISION	PAGES	DESCRIPTION OF CHANGE	ECO
32DSW03. C.1 02-24-11	Cvr	Update to trademark.	550064
	1-2	Update to warranty text.	
	2-2, 2-11	Update to weight requirement.	
END OF TABLE			

TABLE OF CONTENTS

<i>Chapter</i>	<i>Page</i>
I. INTRODUCTION	1-1
A. PRODUCT SUPPORT	1-1
B. PRODUCT WARRANTY	1-2
C. SHIPMENT INFORMATION	1-3
D. GENERAL SAFETY PRECAUTIONS	1-3
E. MAJOR LIFT COMPONENTS	1-4
F. PLATFORM OPERATING VOLUME	1-7
II. OPERATING INSTRUCTIONS	2-1
A. SAFETY PRECAUTIONS	2-1
B. DAILY SAFETY CHECK	2-3
C. PLATFORM MOTIONS	2-4
D. CONTROLS AND INDICATORS	2-5
• CONTROL PENDANT	2-5
• VEHICLE INTERLOCK SYSTEM.....	2-6
• ARMREST CONTROL SWITCH	2-7
• CIRCUIT BREAKERS AND INDICATOR LIGHTS	2-7
• THRESHOLD WARNING SYSTEM.....	2-9
• WHEELCHAIR LOCATING PLATES	2-9
• MANUAL BACK-UP PUMP	2-10
• LIFT CYCLE COUNTER.....	2-10
E. NORMAL LIFT OPERATION	2-11
1. ENTERING VEHICLE.....	2-11
2. EXITING VEHICLE	2-12
3. STOWING PLATFORM	2-13
F. MANUAL OPERATION	2-14
1. DEPLOY PLATFORM.....	2-14
2. LOWER PLATFORM.....	2-16
3. STOW PLATFORM.....	2-16
G. MAINTENANCE AND REPAIR NOTE	2-16
III. MAINTENANCE	3-1
A. ADDITIONAL MAINTENANCE INFORMATION	3-1
B. CLEANING	3-1
C. MAINTENANCE SCHEDULE	3-1
D. DECAL PART NUMBERS AND LOCATIONS	3-3

This page intentionally left blank.

I. SLIDE-AWAY® EXPORT USE WHEELCHAIR LIFT INTRODUCTION

This manual provides a description, operating, and maintenance instructions for the Ricon Slide-Away® Export Use wheelchair lift. The platform on the Slide-Away folds vertically as it slides to the left. This not only provides vehicle access through the area where the lift is installed, but also allows space for the front passenger seat to be adjusted further rearward.

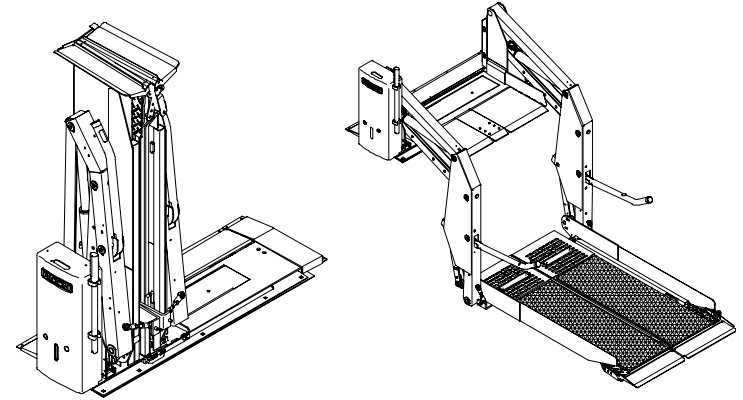

The lift is intended to provide wheelchair access to personal vehicles. The mechanical linkages provide smooth movement to the platform, which has a rated load capacity of 363 kg. The lift can be operated by the wheelchair occupant or by a trained assistant.

The lift contains an electro-hydraulic pump with a built-in manual backup pump. If the lift loses power, it can be deployed, lowered, and stowed manually.

A control pendant is used to unfold the platform out from the vehicle (deploy). The passenger boards the non-skid platform and an operator lowers the platform to the ground. After the passenger departs, the platform is raised and folded back into the vehicle (stow). The platform folds vertically as it slides to the left when stowed.

It is important to passenger safety that these operating instructions be read and understood by the lift operator. For installation instructions and spare parts, please refer to the service manual 32DSW04. After the Slide-Away is installed, it is important to follow the Ricon recommendations for cleaning, inspection and lubricating the wheelchair lift.

A. PRODUCT SUPPORT

If there are questions about this manual, or you need copies, please contact Ricon Product Support at the following location:

Ricon Corporation
7900 Nelson Road
Panorama City, CA 91402(818) 267-3000
Outside 818 Area Code(800) 322-2884
World Wide Website www.vantagemobility.com
Ricon U.K Ltd.

Littlemoss Business Park, Littlemoss Road
Droylsden, Manchester
United Kingdom, M43 7EF (+44) 161 301 6000

B. PRODUCT WARRANTY

RICON CORPORATION SLIDE-AWAY EXPORT USE WHEELCHAIR LIFT FIVE-YEAR LIMITED WARRANTY

Ricon Corporation (Ricon) warrants to the original purchaser of this product that Ricon will repair or replace, at its option, any parts that fail because of defective material or workmanship as follows:

- Repair or replace parts for a period of one year from the date of purchase. A complete list of parts covered by this warranty can be obtained from an authorized Ricon dealer.
- Labor costs for specified parts replaced under this warranty for a period of one year from date put into service. A Ricon rate schedule determines parts covered and labor allowed.
- Repair or replace lift powertrain parts for a period of five years from date of purchase. A complete list of parts covered can be obtained from an authorized Ricon dealer or Ricon product support.

If you need to return a product: Return this product to your installing dealer, or to Ricon, following the Ricon RMA procedure. Please give as much notice as possible, and allow a reasonable amount of time for repair.

This warranty does not cover:

- Malfunction or damage to product parts caused by accident, misuse, lack of proper maintenance, neglect, improper adjustment, modification, alteration, the mechanical condition of the vehicle, road hazards, overloading, failure to follow operating instructions, or acts of nature (i.e., weather, lightning, flood).

NOTE: Ricon recommends that this product be inspected by an authorized Ricon dealer or qualified service technician at least once every six months, or sooner if necessary. Required maintenance should be performed at that time.



THIS PRODUCT HAS BEEN DESIGNED AND MANUFACTURED TO EXACT SPECIFICATIONS.
~ ANY MODIFICATION OF THIS PRODUCT CAN BE HAZARDOUS ~

This warranty is void if:

- The product has been installed or maintained by someone other than an authorized Ricon dealer or qualified service technician.
- The product has been modified or altered in any respect from its original design without written authorization by Ricon.

Ricon disclaims liability for any personal injury or property damage that results from operation of a Ricon product that has been modified from the original Ricon design. No person or company is authorized to change the design of this Ricon product without written authorization by Ricon.

Ricon's obligation under this warranty is exclusively limited to the repair or exchange of parts that fail within the applicable warranty period.

Ricon assumes no responsibility for expenses or damages, including incidental or consequential damages. Some states do not allow the exclusion or limitation of incidental or consequential damages, so the above limitation or exclusion may not apply.

Important: The warranty registration card must be completed and returned to Ricon within 10 days after installation of this Ricon product for the warranty to be valid. The warranty is not transferable.

The warranty gives specific legal rights. There may be other rights that vary in each state.

C. SHIPMENT INFORMATION

- Check the received product for freight damage. Claims for damage should be made to the freight carrier immediately.
- The warranty and owner registration cards must be completed and returned to Ricon within 10 days to validate the warranty.

D. GENERAL SAFETY PRECAUTIONS

The following safety precautions must be adhered to during operation:

- Exercise caution when operating lift to avoid injury, and be certain that hands, feet, legs or clothing are not in path of the platform as it moves.
- Read and thoroughly understand the operating instructions before attempting to operate the lift.
- Inspect product before each use. Do not operate lift if an unsafe condition is present, or there is unusual noise or movement.
- Keep others clear during lift operation.
- The lift requires regular maintenance. Ricon recommends a thorough inspection every six months. Maintain the product at its highest level of performance.

E. MAJOR COMPONENTS

The major components of the lift are in **Figure 1-1**. A description of each component is in **Table 1-1**.

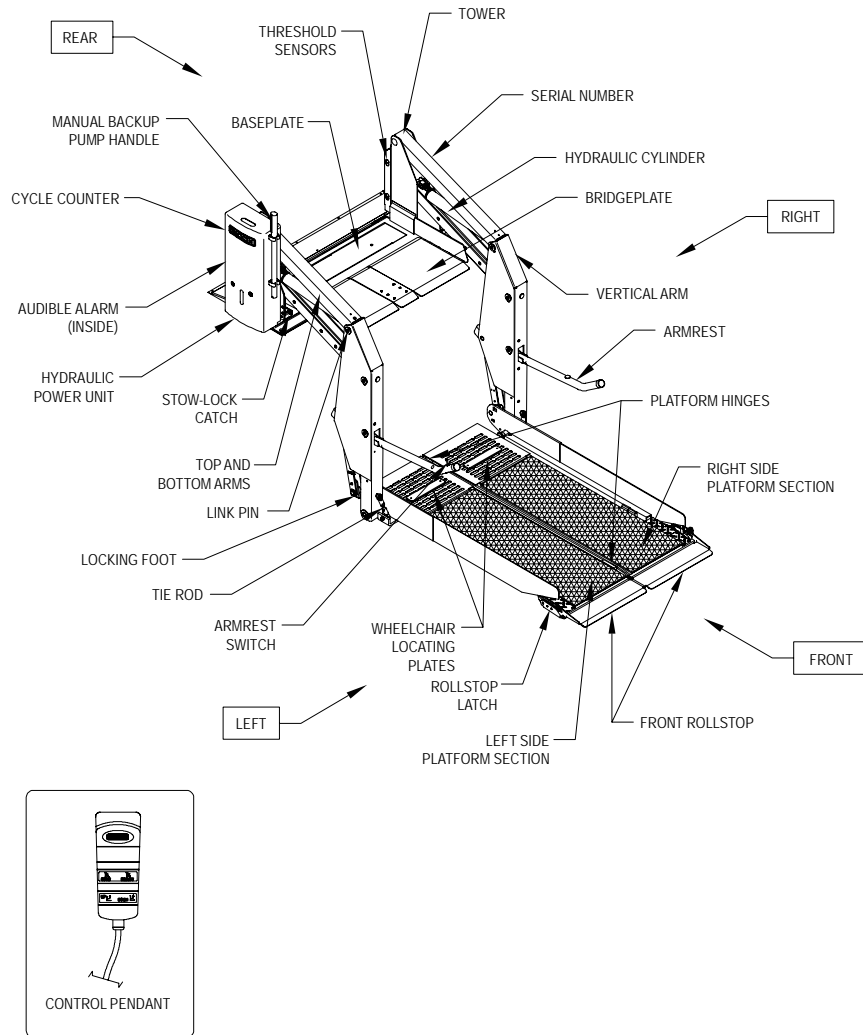

RSM0021900

FIGURE 1-1: SLIDE-AWAY MAJOR COMPONENTS

TABLE 1-1: SLIDE-AWAY MAJOR COMPONENT TERMS	
NAME	DESCRIPTION
Left, right, front, and rear	Position references when installed lift is viewed from outside of vehicle.
Armrest	(left and right) Provides handhold for passenger.
Armrest switch	Allows passenger to control "Up" and "Down" platform motions.
Audible alarm	Announces when something has passed over threshold. Activated by threshold beam.
Baseplate	Bolts to vehicle floor; provides secure foundation for lift structure.
Bridgeplate	Plate that bridges gap between platform and baseplate when platform is at floor level.
Control pendant	Hand-held device used to control platform motions.
Cycle counter	Visible at top rear of housing, it records number of times platform has moved from floor to ground and back to floor.
Front rollstop	(left and right) Front barrier prevents wheelchair from inadvertently rolling off of platform during platform movement.
Hydraulic cylinder	(left and right) Telescoping single-acting cylinders convert hydraulic pressure into platform lifting and folding force.
Hydraulic power unit	Contains hydraulic pump driven by electric motor to produce pressure for raising and folding platform, plus a pressure release valve to unfold and lower it.
Left side platform section	Left portion of platform that unfolds during deploy and folds during stow.
Link pin	(five per side) Pins that arms pivot on.
Locking foot	Engages stow lock catch to prevent the platform from drifting outward when fully stowed.
Manual backup pump handle	Used to operate manual back up-pump (located on hydraulic power unit).
Platform hinges	Two hinges provide connection between left and right platform sections.
Right side platform section	Right portion of platform that unfolds during deploy and folds during stow.
Rollstop latch	(left and right) Locks rollstop in up position or unlocks rollstop to allow it to lower.
Serial number	Location of lift serial number decal.
Stow lock catch	Engages lock when platform is fully stowed. (See Locking Foot).
CONTINUED	

TABLE 1-1: SLIDE-AWAY MAJOR COMPONENT TERMS	
NAME	DESCRIPTION
Threshold beam	(upper and lower) Light-beams detect presence of objects in threshold area.
Tie-Rod	(left and right) Links on split platform that cause platform halves to fold as platform stows.
Top and bottom arms	(left and right) Upper and lower links that connect vertical arms to baseplate.
Tower	(left and right) Supports arms and platform sections when folded or deployed. Right tower slides to right while platform unfolds.
Vertical arm	(left and right) Connects platform to top and bottom arms.
Wheelchair locating plates	Plates indicate to occupant how far rearward the wheelchair should be positioned on the platform.
END OF TABLE	

F. PLATFORM OPERATING VOLUME

Refer to **Figure 1-2**. The useful lift operating volume is represented in the figure by the rectangular volume shown in phantom outline. It is centered above the platform. Refer to **Table 1-2** for the dimensions that correspond to your lift model.

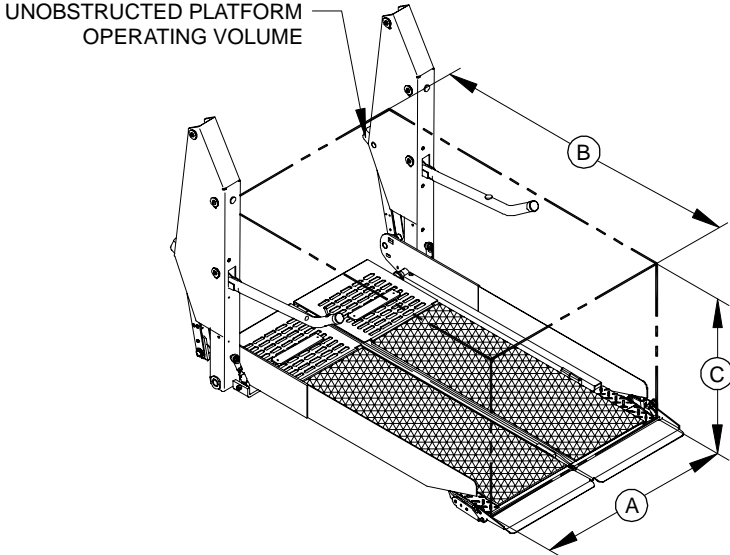

RSM0021800

FIGURE 1-2: PLATFORM OPERATING VOLUME

TABLE 1-2: SLIDE-AWAY OPERATING VOLUME DIMENSIONS, inches			
MODEL	A	B	C
ST00	30	42	30
ST01	30	48	30
END OF TABLE			

This page intentionally left blank.

II. SLIDE-AWAY EXPORT USE LIFT OPERATING INSTRUCTIONS

This chapter contains safety precautions, daily safety check instructions, control and indicator descriptions, and operating instructions for the Ricon Slide-Away Export Use wheelchair lift. This chapter must be thoroughly understood by operator before using lift.

A. SAFETY PRECAUTIONS

The following safety precautions must be complied with at all times when operating lift:

- Refer to **Figure 2-1**. Deploying the lift when vehicle is on sloped ground is hazardous. Operate lift with vehicle parked on level ground.

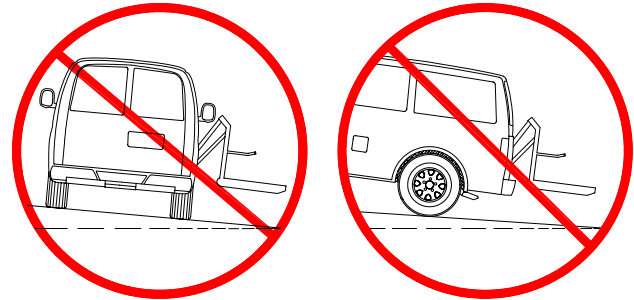

FIGURE 2-1: SLOPED PARKING HAZARD

- Vehicle must be safely parked with parking brake set before using lift.
- Inspect lift before use. Do not use lift if an unsafe condition exists, or unusual noises or movements are noticed, and contact a Ricon authorized dealer for repair.
- Read and comply with all warning labels and symbols affixed to wheelchair lift.
- Refer to **Figure 2-2**. Wheelchair occupant must face outward on platform when entering or exiting vehicle to minimize the possibility of the large rear wheels rolling up and over the front rollstop.



FIGURE 2-2: DON'T EXIT FACING BACKWARDS

- Wheelchair occupant must not locate the large rear wheel to the rear of the wheelchair locating plates (at rear of platform) when entering the vehicle, nor locate to the rear of the plates when exiting the vehicle. Wheelchair locating plates are not intended to stop a moving wheelchair. Incorrect placement of wheelchair on platform will interfere with lift operation and may endanger wheelchair occupant.

- When exiting vehicle, verify that platform is at same height as floor and front rollstop is up and locked.
- Do not rely on a threshold-warning device (audible, or other) to confirm that it is safe to exit backwards. This device may be inoperative or unheard, and you might exit backwards when the platform is on the ground!
- Do not place large equipment or furniture inside vehicle that can prevent pivoting of your wheelchair. Being able to pivot assures that you can safely exit facing outward.
- Be certain wheelchair fits safely on platform; it must not extend beyond edges or interfere with operation of front rollstop.
- The raised front rollstop prevents slow and unintentional rolling off of the platform. It is not intended to stop a fast-moving wheelchair, which might tip forward if the small front wheels collide with the rollstop.
- Do not operate with a load in excess of 363 kg.
- Keep arms, legs, and clothing away from moving lift parts.
- The lift is intended for one wheelchair and its occupant. It is not designed to transport standing passengers. Do not overload lift.
- Refer to **Figure 2-3**. Do not stand in front of lift while deploying platform.



FIGURE 2-3: STAND CLEAR OF PLATFORM

- Keep others clear while operating lift.
- Do not allow an untrained person to operate lift.
- Careful supervision is necessary if used by or near children.
- Do not allow anyone to stand on bridgeplate. The bridgeplate is not intended to support the weight of a person, and presents the possibility of falling off its front edge.
- Lock wheelchair brakes when on platform (power chair users must turn off power and set brake).
- Use great care in wet conditions, because the wheelchair brakes are less effective if wheels or platform are wet.
- Never leave platform outside of vehicle. Return platform to stowed position after use.
- Do not load an oversize wheelchair into vehicle if it is too large to pivot freely inside vehicle.





Read and understand these safety precautions. Review them periodically and ask other operators to read them as well. Contact a Ricon authorized dealer or Ricon Product Support if you have questions.

B. DAILY SAFETY CHECK

Inspect lift before each use and verify the following conditions are met before operating:

- All functions operate properly. DO NOT use if unusual noises or movements exist, and contact an authorized Ricon dealer for repair.
- Vehicle interlock is operating properly.
- No objects that may interfere with operation are present.
- General appearance and lubrication are satisfactory and all fasteners are tight.

C. PLATFORM MOTIONS

TABLE 2-1: PLATFORM MOTIONS	
MOVEMENT	DESCRIPTION
 DEPLOY	Right tower slides to right as platform unfolds to floor level. If equipped with a power door operator, the doors automatically open before lift deploys.
 DOWN	Platform lowers from vehicle floor level towards ground level. The front rollstop lowers (opens) when rollstop latch contacts ground.
 UP	Platform rises from ground level towards vehicle floor level. The front rollstop rises (closes) when platform leaves ground level.
 STOW	Right tower slides towards left tower as platform folds into stowed position. If equipped with a power door operator, the doors automatically close after lift stows.
END OF TABLE	

NOTE: The up and down motions are available only when platform is deployed.

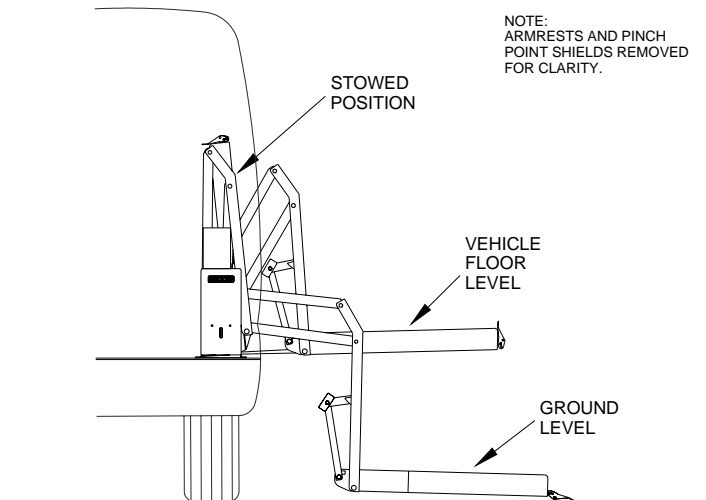

FIGURE 2-4: PLATFORM POSITIONS

D. CONTROLS AND INDICATORS



WARNING!

THE LIFT IS ALLOWED TO OPERATE ONLY WHEN THE LIFT AND VEHICLE INTERLOCK CIRCUITRY REQUIREMENTS ARE MET. IF NECESSARY, REFER TO VEHICLE OPERATOR MANUAL FOR INTERLOCK INSTRUCTIONS. DO NOT ATTEMPT TO OPERATE LIFT WITH INTERLOCK BYPASSED.

■ CONTROL PENDANT

Refer to **Figure 2-5**. The lift is operated with two rocker switches on a hard-wired, hand-held remote control pendant. Control platform movement by pushing and holding one end of a rocker switch. The ends of the switches are referred to in this manual as buttons.

Pushing the DEPLOY button causes the platform to unfold at floor level. Pushing the DOWN button causes the platform to descend towards the ground. Pushing the UP button causes the platform to rise towards floor level. Pushing the STOW button when the platform is at floor level causes it to fold and retract into the vehicle.

Platform motion can be halted at any time by releasing the button.

The pendant will not function unless the vehicle parking brake is set and the transmission is in PARK. In addition, the deploy function is not available if the vehicle doors are closed.

The pendant is usually stored on a wall clip in an interior location that is near the lift.

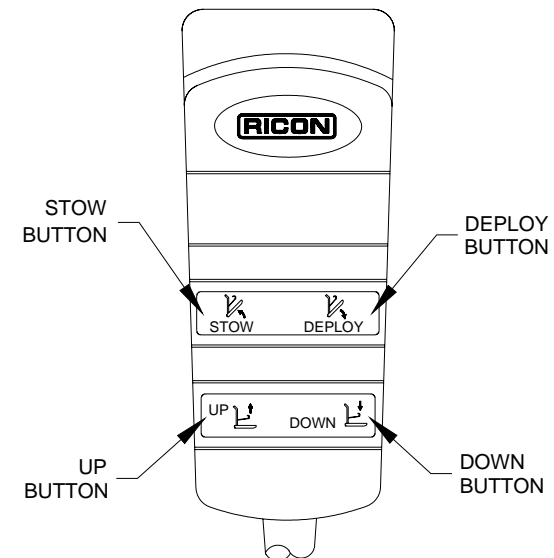

FIGURE 2-5: CONTROL PENDANT

■ VEHICLE INTERLOCK SYSTEM

Refer to **Figure 2-6**. The Slide-Away lift provides an electrical interlock signal to the vehicle that prevents movement of the vehicle unless the platform is fully stowed. The interlock control also supplies power to the lift only when the vehicle parking brake is set and the transmission is in PARK.

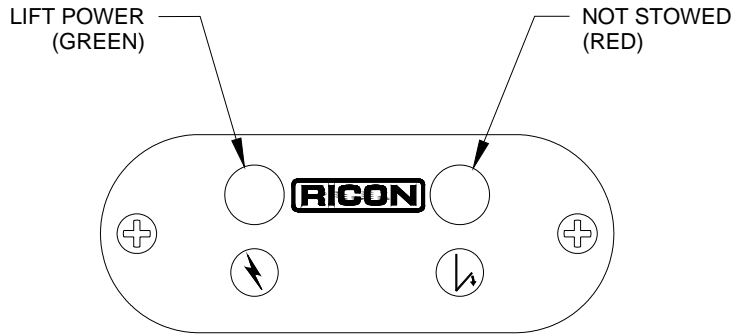



FIGURE 2-6: INTERLOCK DISPLAY PANEL

The figure shows an LED display panel that is attached to your vehicle dashboard. The Lift Power LED lights green when the vehicle transmission is in PARK and the parking brake is set. While the LED is green the lift is powered and the platform can be deployed. The Not Stowed LED lights red when the platform is not fully stowed into the vehicle. While the LED is red the transmission cannot be shifted out of PARK.

 WARNING!
BEFORE USING THE FOLLOWING PROCEDURE YOU MUST VERIFY THAT THE PLATFORM IS IN FACT FULLY STOWED INTO THE VEHICLE. FAILURE TO DO SO CAN RESULT IN VEHICLE OR LIFT DAMAGE AND COULD SUBJECT THE OPERATOR, OR OTHERS, TO PERSONAL INJURY.

If a failure occurs in the interlock or lift circuitry that results in the red Not Stowed LED lighting (which also prevents vehicle movement) the following procedure will override the interlock system:

- a. Turn vehicle ignition key to the ON position.
- b. Shift vehicle transmission to neutral.
- c. Start vehicle.
- d. Shift to drive and proceed to a dealer for service.

■ ARMREST CONTROL SWITCH

Refer to **Figure 2-7**. An additional lift control switch is located on the left side platform armrest. The spring-loaded switch lever can be used by the passenger to control UP and DOWN motions of the platform. To move platform downward push and hold switch lever forward, and to move platform upward pull and hold lever back. Release lever at any time to halt motion.

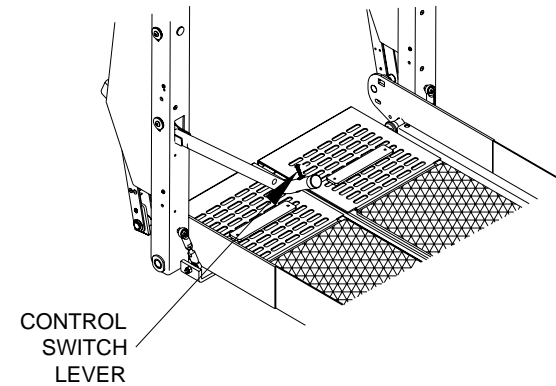

FIGURE 2-7: LIFT CONTROL SWITCH

■ CIRCUIT BREAKERS AND INDICATOR LIGHTS

- Interlock Indicator Light

Refer to **Figure 2-8**. The purpose of a vehicle interlock system is to prevent operation of lift if an unsafe condition is present. When a vehicle interlock system is interfaced with the lift circuitry, the interlock indicator shows whether or not the interlock is operating properly. The light is interfaced with the electrical system so that regardless of which interlock system is used, the light will be on when the interlock provides power to lift and off when interlock has removed power to lift. When there is no interlock system installed the light stays illuminated at all times.

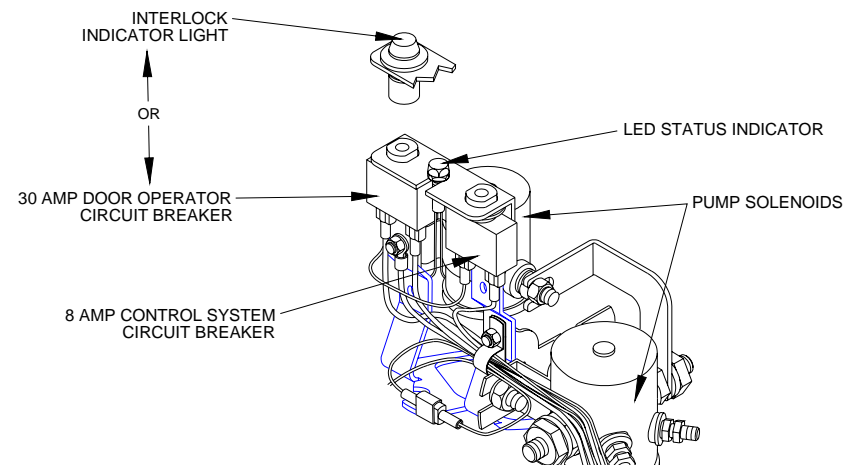

FIGURE 2-8: INDICATOR LIGHT, CIRCUIT BREAKERS, AND LED INDICATOR

- Optional Door Operator Circuit Breaker

Refer to **Figure 2-8**. The 30-amp circuit breaker for an optional door operator is located on the hydraulic pump assembly. In the event of a door operator short circuit, the circuit breaker button pops outward. If pressing and releasing button does not reset power, do not press and hold. Contact a Ricon authorized dealer for repair. Refer to appropriate Remote Power Door operator manual for a detailed description.

- Control System Circuit Breaker

Refer to **Figure 2-8**. The 8 amp control system circuit breaker is located on the hydraulic pump assembly. In the event of a control system short circuit, the circuit breaker button pops outward. If pressing and releasing button does not reset power, do not press and hold. Contact a Ricon authorized dealer for repair.

- Pump Solenoid LED Status Indicator

Refer to **Figure 2-8**. Two hydraulic pump solenoids are located at the top of the pump assembly. A green LED status indicator is located between the 30 amp and 8 amp circuit breakers. The LED is on when both solenoids are operating correctly. If either, or both, solenoids fail the LED will be off. For more information on this LED refer to the service manual 32DSW04.

- Main Circuit Breaker

Refer to **Figure 2-9**. The main circuit breaker is located in the vehicle engine compartment and is used to interrupt electrical power to the entire lift electrical system when a major short circuit occurs. In such an event, the circuit breaker reset tab will “flip-down”. If pressing reset tab back up (as shown by arrow) and releasing it does not reset power, do not press and hold tab. Contact a Ricon authorized dealer for repair.

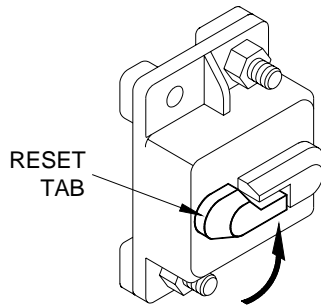

FIGURE 2-9: MAIN CIRCUIT BREAKER

■ THRESHOLD SAFETY WARNING SYSTEM

Refer to **Figure 2-10** for the location of the threshold warning system components. The lift incorporates two light beams that detect when a passenger (or object, such as a wheelchair) is in the vicinity of the baseplate (threshold area). The beams are enabled when the platform is one inch, or more, below the vehicle floor, and an audible buzzer is actuated if someone passes through either of the beams. This system provides a margin of safety for lift users by warning them if the platform is below floor level. The platform must be at floor level when boarding the platform prior to exiting the vehicle.

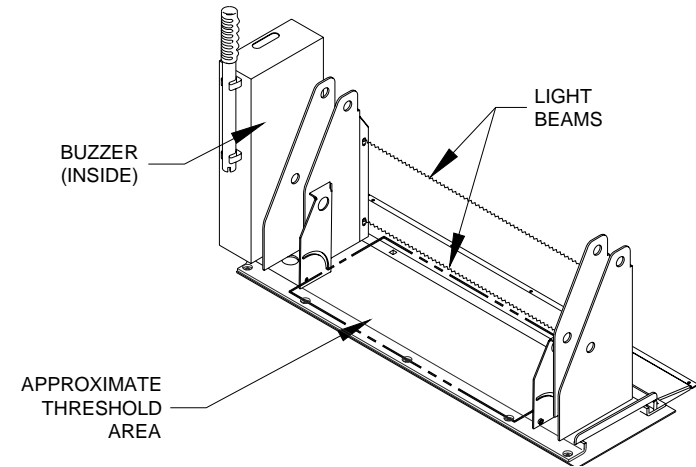

FIGURE 2-10: THRESHOLD WARNING SYSTEM

■ WHEELCHAIR LOCATING PLATES

Refer to **Figure 2-11**. The wheelchair locating plates (at rear of platform) indicate to occupant how far rearward the wheelchair is positioned on the platform. The wheelchair's large rear wheels must be located to the front of the locating plates. This applies to entering and exiting the vehicle. Locating the rear wheels behind these plates will interfere with lift operation and may endanger wheelchair occupant. The wheelchair must not extend beyond the front or rear edges of platform. For adjustment instructions, please refer to the Slide-Away Export Use service manual part number 32DSW04.

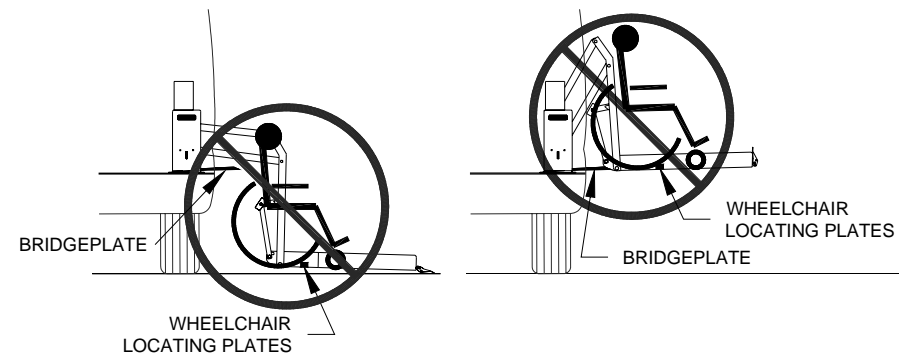

FIGURE 2-11: INCORRECT WHEELCHAIR PLACEMENT

1. MANUAL BACK-UP PUMP

Refer to **Figure 2-12**. The manual backup pump is used to operate the lift if electrical power is not functioning. Controls for the pump consist of a pump handle to raise the platform and a pump pressure release valve to lower it. Instructions for operating the manual pump are provided in the Manual Operation Section later in this chapter.

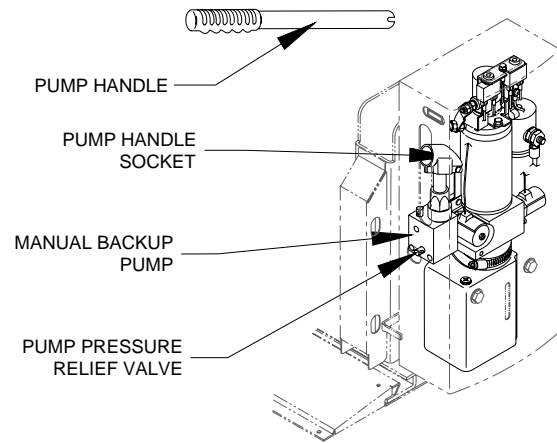

FIGURE 2-12: MANUAL BACKUP PUMP & HANDLE

■ LIFT CYCLE COUNTER

Refer to **Figure 2-13**. The cycle counter is located inside the hydraulic pump housing and visible through a slot on the rear side. The counter advances each time the platform moves through a complete cycle, which consists of the platform moving from the vehicle floor to the ground and back to the floor. The number of cycles displayed is used to schedule maintenance operations.

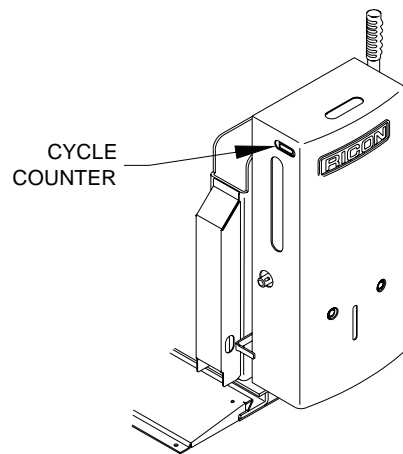



FIGURE 2-13: CYCLE COUNTER

E. NORMAL LIFT OPERATION

 WARNING!	
<ul style="list-style-type: none">▪ IMPROPER USE OF LIFT CAN RESULT IN PERSONAL INJURY. USERS MUST READ AND FOLLOW OPERATING INSTRUCTIONS. ADDITIONAL COPIES OF OPERATOR MANUAL ARE AVAILABLE FROM:	<p>RICON CORPORATION 7900 NELSON ROAD PANORAMA CITY, CA 91402 (818) 267-3000 or (800) 322-2884</p>
<ul style="list-style-type: none">▪ DO NOT EXCEED RATED LOAD CAPACITY OF 363 kg.▪ PRIOR TO USE, INSPECT WHEELCHAIR LIFT FOR PROPER FUNCTION, REQUIRED MAINTENANCE, OR DAMAGE. IF A PROBLEM EXISTS, DO NOT USE LIFT AND CONTACT A RICON AUTHORIZED DEALER FOR REPAIR.▪ THIS LIFT IS DESIGNED FOR USE BY WHEELCHAIR OCCUPANTS ONLY.	
<p>RICON CORPORATION DISCLAIMS LIABILITY FOR DAMAGE OR PERSONAL INJURY RESULTING FROM MODIFICATION TO LIFT, LACK OF MAINTENANCE OR REPAIR, NEGLIGENCE, ABUSE, OR FAILURE TO FOLLOW LIFT OPERATING INSTRUCTIONS.</p>	

- Before operating lift, be certain vehicle is safely parked on a level area away from traffic. Provide space for lift operation and passenger boarding.
- The lift operator must take special care to be certain that area is clear before deploying lift. Be certain there are no obstacles present on the baseplate and beneath platform.
- Open doors completely if lift is not equipped with a power door operator. If so equipped, the vehicle doors will automatically open before platform deploys and close after platform is stowed.
- Verify that the vehicle parking brake is set and the transmission is in PARK if vehicle is equipped with an interlock control (the interlock control supplies power to the lift). The lift will not operate until this feature has been engaged properly. Refer back to Controls and Indicators section for more detail.

 WARNING!
IF POSSIBLE, SOMEONE SHOULD BE NEAR LIFT PASSENGER TO RENDER IMMEDIATE ASSISTANCE IF NECESSARY.

1. ENTERING VEHICLE:

 WARNING!
THE RIGHT TOWER SLIDES TO THE RIGHT AS THE PLATFORM DEPLOYS. VERIFY THAT NO ONE IS STANDING ON THE BASEPLATE AND THAT THERE ARE NO OBSTACLES PRESENT BEFORE DEPLOYING PLATFORM.

- a. **DEPLOY PLATFORM** - Push and hold DEPLOY button until platform is completely unfolded from vehicle and stops at floor level.

- b. **LOWER PLATFORM** - Push and hold DOWN button until platform is at ground level and front rollstop is fully lowered.

 CAUTION!
Be certain wheelchair is clearly within perimeter of platform and does not interfere with operation of rollstop.

 WARNING!
MAKE SURE LARGE REAR WHEELS DO NOT GO TO REAR OF LOCATING PLATES AT REAR OF PLATFORM.

- c. Carefully place wheelchair in center of platform, facing outward (away from vehicle), and lock wheelchair brakes.
- d. **RAISE PLATFORM** - Push and hold UP button until platform rises and stops at floor level.
- e. Release wheelchair brakes and carefully enter vehicle.
- f. Refer to “Stowing Platform” section below to stow platform.

2. EXITING VEHICLE:

 WARNING!
THE RIGHT TOWER SLIDES TO THE RIGHT AS THE PLATFORM DEPLOYS. VERIFY THAT NO ONE IS STANDING ON THE BASEPLATE AND THAT THERE ARE NO OBSTACLES PRESENT BEFORE DEPLOYING PLATFORM.

- a. **DEPLOY PLATFORM** - Push and hold DEPLOY button until platform is completely unfolded from vehicle and stops at floor level.

 WARNING!
VERIFY THAT PLATFORM IS AT VEHICLE FLOOR LEVEL AND THAT FRONT ROLLSTOP IS UP AND LOCKED IN POSITION.

 WARNING!
MAKE SURE LARGE REAR WHEELS ARE IN FRONT OF LOCATING PLATES AT REAR OF PLATFORM.

- b. Carefully place wheelchair in center of platform, facing outward (away from vehicle), and lock wheelchair brakes.

 WARNING!
DO NOT ALLOW ANYONE TO STAND ON BRIDGEPLATE AS PLATFORM LOWERS.

- c. **LOWER PLATFORM** - Push and hold DOWN button until platform is at ground level and front rollstop is fully lowered.
- d. Release wheelchair brakes and carefully exit platform.
- e. Refer to “Stowing Platform” section below to stow platform.

3. STOWING PLATFORM:

- From ground level:
 - a. Push and hold UP button until platform stops at floor level.

 WARNING!
THE RIGHT TOWER SLIDES TOWARDS THE LEFT TOWER AS THE PLATFORM FOLDS INTO STOWED POSITION. VERIFY THAT NO ONE IS STANDING ON THE BASEPLATE AND THAT THERE ARE NO OBSTACLES PRESENT BEFORE STOWING PLATFORM.

- b. Push and hold STOW button until platform folds completely into vehicle.
- From vehicle floor level:
Push and hold STOW button until platform folds completely into vehicle.

 CAUTION!
Be certain platform has stowed completely before attempting to close doors. To avoid damage to doors, do not release STOW button until lift pump motor stops.

- Close doors:
Close vehicle doors by hand if lift is not equipped with power door operators. If equipped with power door operators, the vehicle doors will automatically close after platform is stowed.
- Interlock circuitry:
The following procedure will override the interlock system if it fails and prevents storing the platform (and causes the red Not Stowed LED to light). Refer back to the Controls and Indicators section for more detail.
 - 1) Turn vehicle ignition key to ON position.
 - 2) Shift vehicle transmission to neutral.
 - 3) Start vehicle.
 - 4) Shift to drive and proceed to a dealer for service.

NOTE: If this procedure does not work, refer ahead to the Stow Platform paragraph in the Manual Operation section.

F. MANUAL OPERATION

The lift can be operated manually if the hydraulic pump is not functioning or the primary electrical power source is absent. Ricon recommends that manual operation be used only for exiting passengers from vehicle.

Preparation:

- Be certain vehicle is on a level area and away from traffic. Allow space for platform movement plus space to exit from platform.
- The vehicle operator must summon assistance to move vehicle to a safe area if a breakdown situation exists where vehicle cannot be moved under its own power.
- Open doors manually if vehicle is not equipped with a power door operator. If equipped with a power door operator, refer to its operator manual for manual operation directions.



NOTE: The threshold warning system is not active during manual operation and cannot be used to indicate platform height.

1. DEPLOY PLATFORM



- Refer to **Figure 2-14**. Insert notched end of pump handle (stored on front side of hydraulic pump unit) into circular hole on rear side of hydraulic pump cover and engage pump release valve.

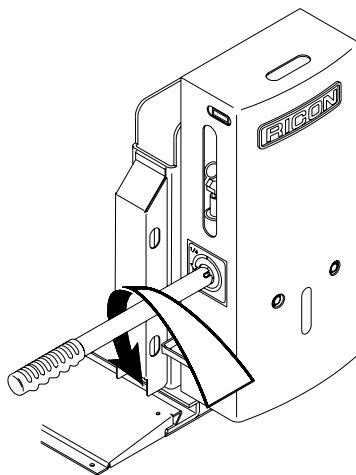
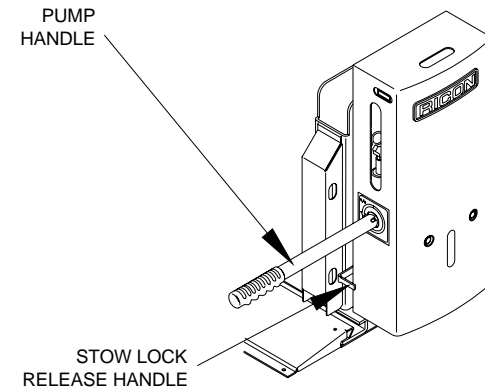

FIGURE 2-14: OPEN RELEASE VALVE

**CAUTION!**

Do not open pump release valve more than 1/4 turn. Opening valve further may cause it to disengage from pump body, which will disable manual pump.

- b. Refer to **Figure 2-14** (previous page). Open release valve by turning it 1/4 turn counterclockwise to release pressure.
- c. Refer to **Figure 2-15**. Hold valve open while pulling stow lock release handle to override stow lock feature. Overriding this feature allows the platform to deploy.

**FIGURE 2-15: OVERRIDE STOW LOCK**

- d. Refer to **Figure 2-16**. When platform reaches vehicle interior floor level turn valve clockwise to close; do not over-tighten valve. Do not lower platform below vehicle floor level. The front edge of bridgeplate must rest flat on platform.

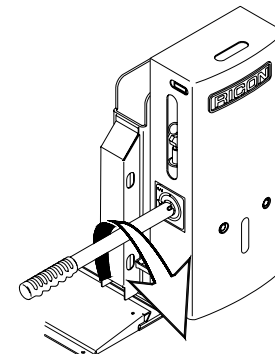
**FIGURE 2-16: CLOSE RELEASE VALVE****WARNING!**

MAKE SURE LARGE REAR WHEELS ARE IN FRONT OF LOCATING PLATES.

- e. Load Passenger
Carefully place wheelchair in center of platform, facing outward (away from vehicle), and lock wheelchair brakes.

2. LOWER PLATFORM

CAUTION!

Do not open pump release valve more than ¼ turn. Opening valve further may cause it to disengage from pump body, which will disable manual pump.

- a. Refer back to **Figure 2-14**. Turn valve 1/4 turn counterclockwise to lower platform.
- b. Hold valve open until platform settles at ground level. Refer back to **Figure 2-16**. Turn valve clockwise to close; do not over-tighten valve.
- c. Release wheelchair brakes and carefully exit platform.

3. STOW PLATFORM

WARNING!

THE RIGHT TOWER SLIDES TOWARDS THE LEFT TOWER AS THE PLATFORM FOLDS INTO STOWED POSITION. VERIFY THAT NO ONE IS STANDING ON THE BASEPLATE AND THAT THERE ARE NO OBSTACLES PRESENT BEFORE STOWING PLATFORM.

- a. Refer back to **Figure 2-16**. Verify that pump release valve is closed; do not over-tighten valve.
- b. Refer to **Figure 2-17**. Insert pump handle into pump handle socket. Operate pump to raise platform to floor level.

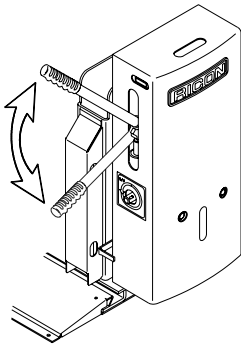

FIGURE 2-17: RAISE PLATFORM

- c. Continue to operate pump until platform is completely folded inside vehicle and stow lock has engaged.
- d. Stow pump handle. Close vehicle doors.

G. MAINTENANCE AND REPAIR NOTE

Follow the lubrication, cleaning, and maintenance instructions in the following chapter, MAINTENANCE. These instructions optimize the operation of the wheelchair lift.

III. SLIDE-AWAY EXPORT USE LIFT MAINTENANCE

Regular maintenance of the Ricon Slide-Away Export Use wheelchair lift will provide optimum performance and reduce the need for repairs. This chapter contains cleaning instructions, a maintenance schedule, and decal information.

A. ADDITIONAL MAINTENANCE INFORMATION

Additional maintenance information is available in the Slide-Away Export Use service manual, part number 32DSW04. This manual is available from Ricon in printed hard copy, or at the Ricon website in PDF format. The website is located at www.riconcorp.com. At the website, click on “Technical Documents”, “I agree”, and then “Service Manuals”.

 WARNING!
<p>THIS RICON PRODUCT IS HIGHLY SPECIALIZED. MAINTENANCE AND REPAIRS MUST BE PERFORMED BY A RICON AUTHORIZED DEALER USING RICON REPLACEMENT PARTS. MODIFYING OR FAILING TO PROPERLY MAINTAIN THIS PRODUCT WILL VOID THE WARRANTY, AND MAY RESULT IN UNSAFE OPERATING CONDITIONS.</p>

B. CLEANING

Regular cleaning with mild soap (i.e. liquid hand soap or car wash liquid) and drying thoroughly will protect lift painted surfaces. Cleaning is especially important in areas where roads are salted in winter. Verify that lift pivot points are clean and dry prior to lubrication.

C. MAINTENANCE SCHEDULE

Refer to cycle counter located on rear side of hydraulic power unit. Under normal operating conditions, maintenance inspections are required at the frequencies listed in **Table 3-1**. Perform maintenance more frequently if the lift is operated in a harsh environment.

TABLE 3-1: MAINTENANCE SCHEDULE	
SERVICE POINT	ACTION TO PERFORM
DIALY OPERATION	
Overall condition	Listen for abnormal noises as lift operates (i.e. grinding or binding noises.)
Control pendant	Verify that control pendant is undamaged and cable connector is tight.
Threshold warning system	Verify that system properly detects objects in threshold area and actuates the audible alarm.
200 CYCLES	
Overall condition	Inspect underside of vehicle for anything that is out of place.
Electrical wiring	Inspect electrical wiring for frayed wires, loose connectors, etc.
Vehicle interlock	Place vehicle in non-interlock mode and verify that lift does not operate.
Decals	Verify that lift decals are properly affixed, clearly visible, and legible. Replace, if necessary. Refer to section D.
Armrests	Verify that armrest fasteners are properly tightened.
CONTINUED	



TABLE 3-1: MAINTENANCE SCHEDULE	
SERVICE POINT	ACTION TO PERFORM
Lift mounting points	<ul style="list-style-type: none"> ▪ Verify that vehicle mounting and support points are undamaged. ▪ Verify that mounting bolts are sufficiently tight and corrosion free.
Main lifting pivots	Verify that link pins on arms are properly installed, free from damage, and locked in position.
Platform pivot points	Verify that platform moves freely, without binding, and does not wobble.
Bridgeplate	<ul style="list-style-type: none"> ▪ Verify that bridgeplate operates without binding during lift functions. ▪ Verify bridgeplate rests flat against platform.
Front rollstop	<ul style="list-style-type: none"> ▪ Verify that rollstop is opened completely when platform is at ground level. ▪ Verify that rollstop closes and locks when platform leaves ground.
1000 CYCLES	
Hydraulic power unit	 CAUTION!
	Check and add fluid when platform is at <u>ground</u> level. Fluid that is added when platform is raised will overflow when platform is lowered.
	<ul style="list-style-type: none"> ▪ Verify that pump hydraulic fluid level is at FULL mark when platform is at ground level. Add Texaco 01554 Aircraft Hydraulic Oil or equivalent U.S. mil spec H5606G fluid. ▪ Verify there are no hydraulic fluid leaks. ▪ Verify that manual backup pump operates properly.
Cleaning and lubrication	<ol style="list-style-type: none"> 1. Clean lift with mild soap and water and wipe dry. Prevent rust by coating all surfaces with a light weight oil. Remove excess oil. 2. Spray penetrating oil (Curtisol® Red Grease 88167 or WD-40®) where specified in the service manual 32DSW04 following directions on container. Remove excess grease from surrounding areas.
Sliding tower	Inspect all rollers at bottom of traveling tower. Rollers must turn freely, be free of flat spots, and secure to the roller axles.
Baseplate tracks	<ol style="list-style-type: none"> 1. Remove baseplate access cover. 2. Clear any debris from front and rear tracks with compressed air. Inspect springs, gas spring, wire cable, electrical harness, and hydraulic lines.
 CAUTION!	
A Ricon authorized dealer must perform the annual safety check.	
CONTINUED	

TABLE 3-1: MAINTENANCE SCHEDULE	
SERVICE POINT	ACTION TO PERFORM
2500 CYCLES (ANNUAL SERVICE)	
Hydraulic cylinder, hoses and fittings	<p>Annual Service must be completed by a certified Ricon dealer. The following service checklist is required during annual service.</p> <ul style="list-style-type: none"> ▪ Check hydraulic cylinder for evidence of leaks. Retighten cylinder pin retaining fasteners (2 per cylinder). ▪ Inspect hydraulic hoses for damage. Replace if damaged. ▪ Verify that all fittings are tight. Retighten all hydraulic fittings accordingly. ▪ Retighten lift mounting bolts, replace if damaged or corroded. ▪ Retighten set screws securing platform pivot pins at bottom of each vertical arm. Secure with medium strength thread lock compound. ▪ Retighten platform pivot pin retaining plate fasteners. Secure with medium strength thread lock compound. ▪ Retighten arm pivot pins. ▪ Retighten armrest bolts to knuckle assembly.
5000 CYCLES	
Torsion springs, gas springs	<p>5000 Cycle Service must be completed by a certified Ricon dealer. The following service checklist is required during 5000 Cycle service. Refer to Service manual for detailed diagram and part numbers.</p> <ul style="list-style-type: none"> ▪ Replace torsion springs. ▪ Replace deploy assist gas springs located in baseplate. ▪ Replace both bridgeplate deploy gas springs.
END OF TABLE	

D. DECAL PART NUMBERS AND LOCATIONS

Refer to **Figure 4-1** in the Spare Parts chapter of the Service Manual (32DSW04). Inspect decals at interval in **Table 3-1**. Inspect for chipping, peeling, fading, and illegibility. Order replacement decals with the part numbers given in **Figure 4-1** and apply where shown.

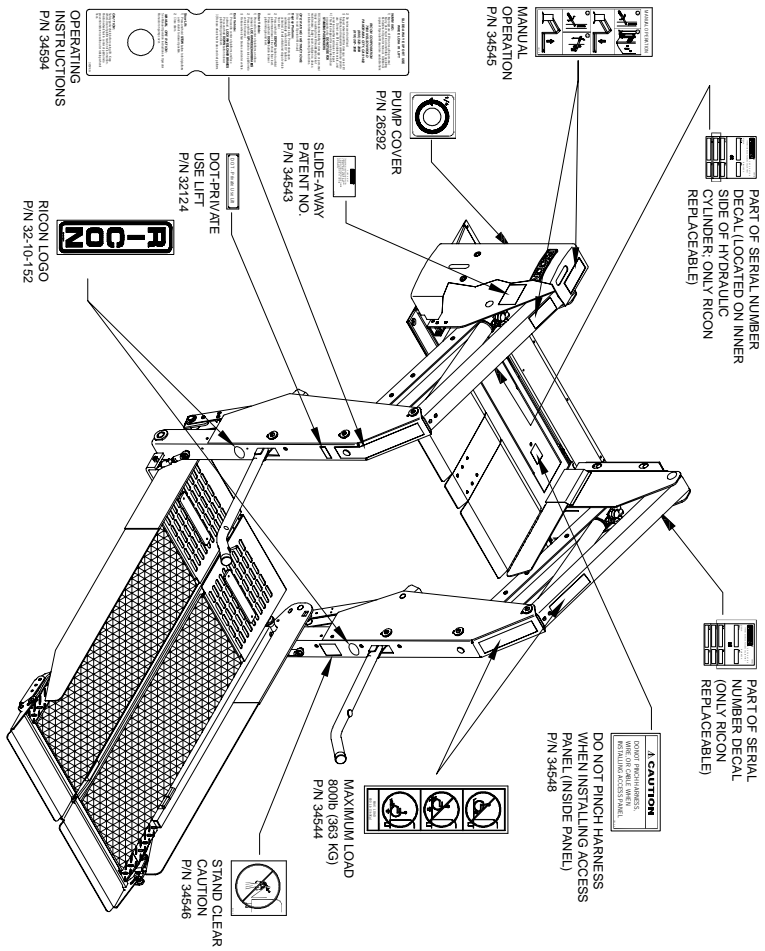

FIGURE 3-1: SLIDE-AWAY PRIVATE USE DECALS