

RICON®

INNOVATION IN MOBILITY™

KlearVue K-Series Folding Platform DOT – Private Use Lift

PRINT

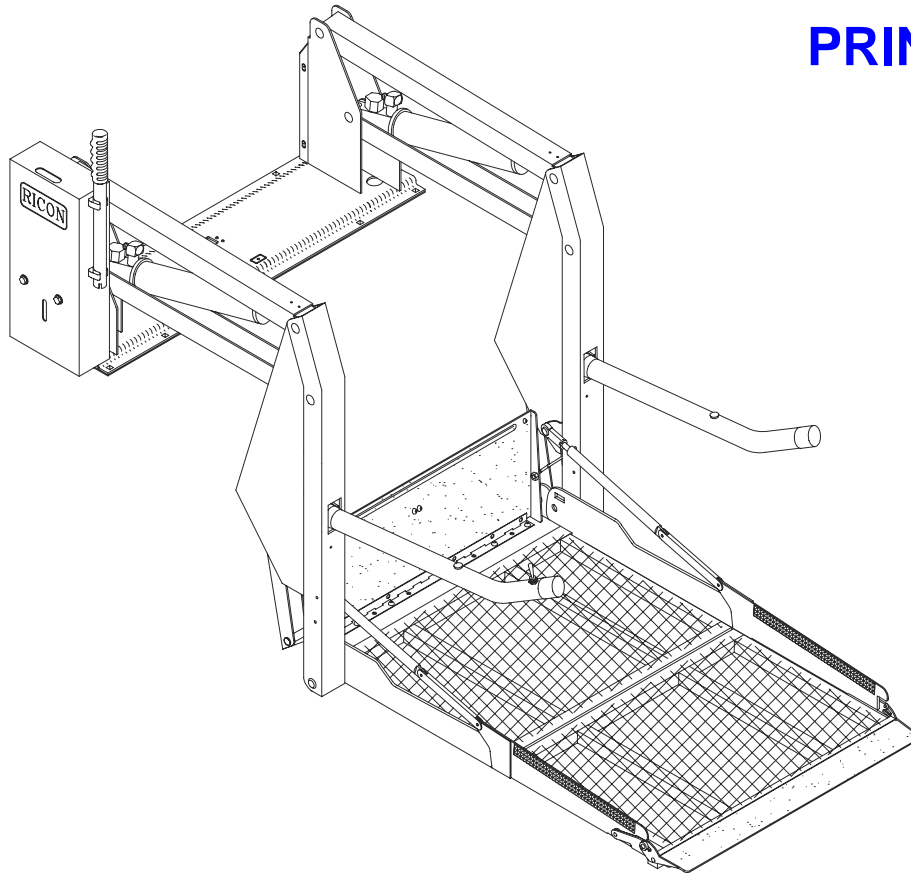

SERVICE MANUAL

This Ricon service manual is for use by qualified service technicians, and is not intended for use by non-professionals. The manual provides essential instructions and reference information, which supports qualified technicians in the correct installation and maintenance of Ricon products.

Qualified service technicians have the training and knowledge to perform maintenance work properly and safely. For the location of a Ricon authorized service technician in your area, call Ricon Product Support at 1-800-322-2884.

“DOT – Private Use Lift” verifies that this platform lift meets only the private use lift requirements of FMVSS no. 403. This lift may be installed on all vehicles appropriate for the size and weight of the lift, except for buses, school buses, and multi-purpose passenger vehicles other than motor homes with a gross vehicle rating (GVWR) that exceeds 10,000 lbs (4,536 kgs).

Customer Name: _____

Installing Dealer: _____

Date Installed: _____

Serial Number: _____

REVISION RECORD

REV	PAGES	DESCRIPTION OF CHANGE	ECO
32DSSK04. A	All	New release.	5642

TABLE OF CONTENTS

<i>Chapter</i>	<i>Page</i>
I. INTRODUCTION	1-1
A. WARRANTY INFORMATION	1-2
B. SHIPMENT INFORMATION	1-3
C. GENERAL SAFETY PRECAUTIONS	1-3
D. MAJOR PRIVATE USE LIFT COMPONENTS	1-4
II. INSTALLATION	2-1
A. GENERAL MECHANICAL INSTALLATION	2-1
1. LIFT LOCATION	2-1
2. LIFT INSTALLATION GUIDELINES	2-1
3. LIFT INSTALLATION INTO VANS.....	2-2
B. ELECTRICAL INSTALLATION	2-5
1. INSTALL MAIN CIRCUIT BREAKER	2-5
2. ROUTE AND CONNECT MAIN POWER CABLE.....	2-6
3. CONNECT CONTROL PENDANT	2-7
4. GROUND (COMMON) CONNECTIONS	2-8
5. INTERLOCK DEVICE INSTALLATION.....	2-9
C. FINAL ADJUSTMENTS	2-9
1. LIMIT SWITCH ADJUSTMENT	2-9
2. PLATFORM TILT ADJUSTMENT	2-11
3. PLATFORM FOLDING LINKAGE ADJUSTMENT	2-12
4. PLATFORM PRESSURE SWITCH CHECK AND ADJUSTMENT	2-12
D. VERIFY INSTALLATION	2-14
E. CUSTOMER ORIENTATION	2-14
III. MAINTENANCE AND REPAIR	3-1
A. LUBRICATION	3-1
B. CLEANING	3-2
C. MAINTENANCE SCHEDULE	3-2
D. TROUBLESHOOTING	3-3
1. LIFT TROUBLESHOOTING	3-3
2. PUMP SOLENOID LED STATUS INDICATOR	3-4
3. BRIDGEPLATE CABLE ASSEMBLY REPLACEMENT	3-4
4. LIMIT SWITCH STATES	3-5
E. HYDRAULIC CIRCUIT DIAGRAM	3-6
F. ELECTRICAL WIRING DIAGRAM	3-7
1. DIAGRAM LEGENDS.....	3-7
2. WIRING DIAGRAM	3-9
IV. SPARE PARTS	4-1
APPENDIX 1: K-SERIES LIFT SPECIFICATIONS	4-24

This page intentionally left blank.

I. INTRODUCTION

The RICON KlearVue Series Private Use wheelchair lift provides wheelchair access to vans. The platform is capable of lifting up to 600 pounds (273 kilograms). The platform is raised with an electro-hydraulic pump and relies on gravity for lowering. The pump has a built-in manual backup pump, so that the platform can be raised or lowered manually.

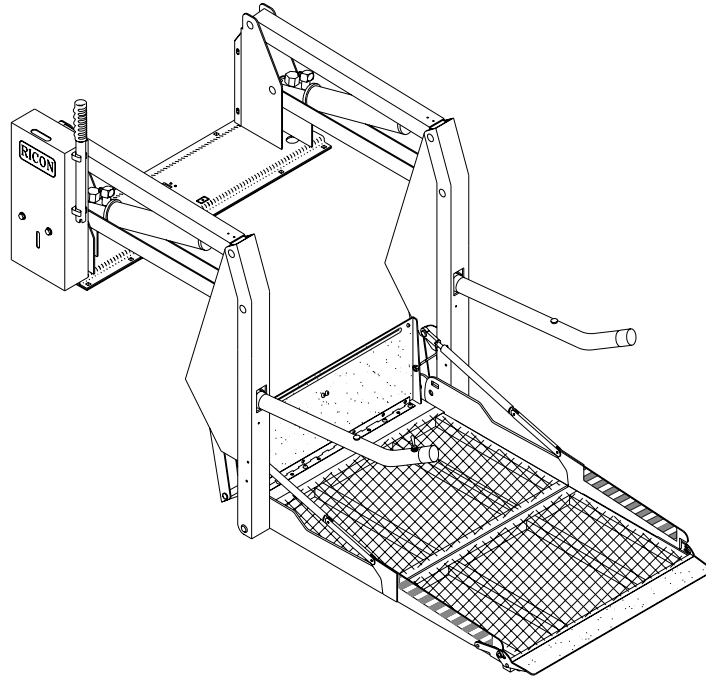

By using the lift control switches, the platform is unfolded from the vehicle (deployed). The passenger boards the large non-skid platform and the operator uses the control switches to gently lower the platform to the ground. After the passenger departs, the platform is raised and folded into the vehicle (stowed). The lift platform splits and folds horizontally when stowed.

This manual contains operation and maintenance instructions and a troubleshooting guide for the lift. It is important to user safety that the lift operators be completely familiar with the Operating Instructions chapter of the operator manual (32DSSK03). Once the lift is installed, it is very important that the lift be properly maintained by following the Ricon recommended cleaning, lubrication, and inspection instructions.

If there are questions about this manual, or additional copies are needed, please contact Ricon Product Support at one of the following locations:

Ricon Corporation
7900 Nelson Road
Panorama City, CA 91402 (818) 267-3000
Outside (818) Area Code (818) 322-2884
World Wide Website www.riconcorp.com

Ricon U.K. Ltd.
Littlemoss Buisness Park, Littlemoss Road
Droylsden, Manchester
United Kingdom, M43 7EF (+44) 161 301 6000

A. RICON FIVE-YEAR LIMITED WARRANTY

RICON CORPORATION FIVE-YEAR LIMITED WARRANTY

Ricon Corporation (Ricon) warrants to the original purchaser of this product that Ricon will repair or replace at its option any parts that fail because of defective material or workmanship as follows:

- Repair or replace parts for a period of one year starting from the date of purchase. A complete list of parts covered by this warranty can be obtained from an authorized Ricon service technician.
- Labor costs for specified parts replaced under this warranty for a period of one year from the date put into service. A Ricon rate schedule determines parts covered and labor allowed.
- Repair or replace lift power train parts for a period of five years from date of purchase. A complete list of parts covered can be obtained from your authorized Ricon service technician or Ricon.

If you need to return a product: Return this Ricon product to your installing dealer or to Ricon. Please give as much advance notice as possible, and allow a reasonable amount of time for repairs.

If you are traveling: All authorized Ricon dealers honor this warranty. Consult the telephone directory or call our Product Support department for the name of the nearest authorized Ricon dealer.

This warranty does not cover: Malfunction or damage to product parts caused by accident, misuse, lack of proper maintenance, neglect, improper adjustment, modification, alteration, the mechanical condition of the vehicle, road hazards, overloading, failure to follow operating instructions, or acts of nature (i.e., weather, lightning, flood).

NOTE: Ricon recommends this product be inspected by an authorized Ricon service technician once every six months or sooner, if necessary. Any required maintenance or repair should be performed at that time.



WARNING

THIS PRODUCT HAS BEEN DESIGNED AND MANUFACTURED TO EXACT SPECIFICATIONS.
ANY MODIFICATION OF THIS PRODUCT CAN BE HAZARDOUS.

This warranty is void if:

The product has not been installed and maintained by an authorized Ricon service technician.

- The product has been modified or altered in any respect from its original design without written authorization by Ricon.

Ricon disclaims liability for any personal injury or property damage that results from operation of a Ricon product that has been modified from the original Ricon design. No person or company is authorized to change the design of this Ricon product without written authorization by Ricon.

Ricon's obligation under this warranty is exclusively limited to the repair or exchange of parts that fail within the applicable warranty period.

Ricon assumes no responsibility for expenses or damages, including incidental or consequential damages. Some states do not allow the exclusion or limitation of incidental or consequential damages, so the above limitation or exclusion may not apply.

Important: The warranty registration card must be completed and returned to Ricon within 20 days after installation of this Ricon product for the warranty to be valid. The warranty is not transferable.

The warranty gives specific legal rights. There may be other rights that vary from state to state.

B. SHIPMENT INFORMATION

- Because of the specialized nature of this product, Ricon does not sell directly to the user. Instead, the product is distributed through a worldwide network of authorized Ricon dealers, who perform the actual installation.
- When the product is received, unpack the product and check for freight damage. Claims for any damage should be made to the carrier immediately.
- Verify that the installation kit contains all the items listed on the enclosed packing list. Please report any missing items immediately to the Ricon Product Support department. The warranty and owner registration cards must be completed and returned to Ricon within 20 days to validate the warranty.

NOTE: The Sales or Service personnel must review the Warranty and the Operator Manual with the user to be certain that they understand how to safely operate the product. Instruct the user to follow the operating instructions without exception.

C. GENERAL SAFETY PRECAUTIONS

The following general safety precautions must be followed during installation, operation, service, and maintenance:

- Under no circumstances should installation, maintenance, repair, and adjustments be attempted without the immediate presence of a person capable of rendering aid.
- An injury, no matter how slight, must be attended to. Administer first aid or seek medical attention immediately.
- Protective eyeshields and appropriate clothing should be worn at all times.
- To avoid injury, exercise caution when operating lift and be certain that hands, feet, legs, and clothing are not in the path of platform movement.
- Batteries contain acid that can burn. If acid comes in contact with skin, immediately flush affected area with water and wash with soap.
- Always work in a properly ventilated area. Do not smoke or use an open flame near battery.
- Do not lay anything metallic on top of battery.
- Check under vehicle before drilling to avoid drilling into frame, subframe members, wiring, hydraulic lines, fuel lines, fuel tank, etc.
- Read and thoroughly understand the operating instructions before operating lift.
- Inspect the lift before each use. If an unsafe condition, such as the presence of unusual noises or movements, do not use lift until the problem is corrected.
- Never load or stand on the platform until the installation is complete. Upon completion of installation, test load the lift mounting integrity at 100% of its rated load capacity.
- Stand clear of doors and platform and keep others clear during operation.
- The product requires regular maintenance. A thorough inspection is recommended at least every six months. The lift must always be maintained at the highest level of performance.

D. MAJOR PRIVATE USE LIFT COMPONENTS

The terms used throughout this manual are illustrated in **Figure 1-1** and defined in **Table 1-1**. Refer to Chapter IV "Spare Parts" for more details.

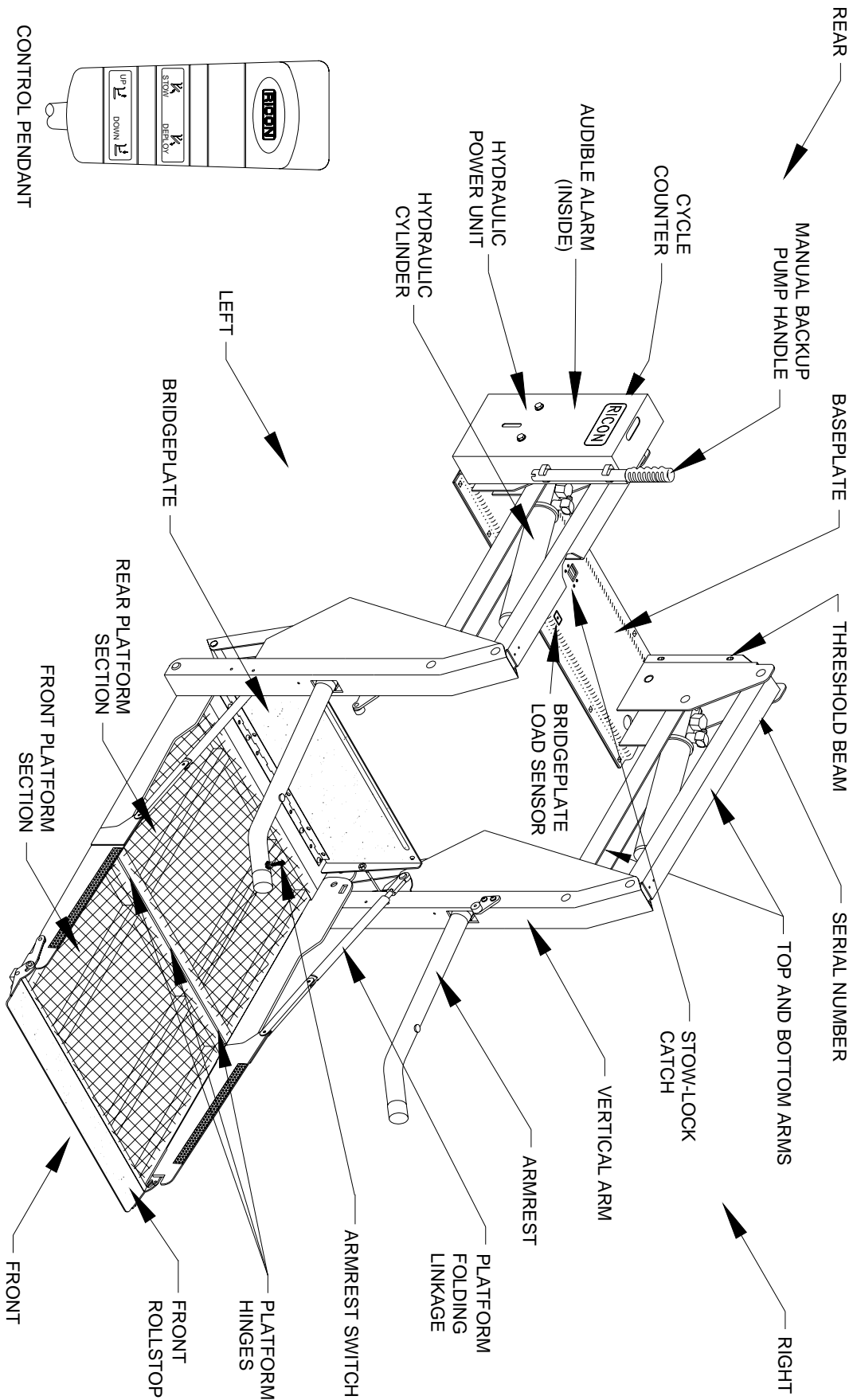

FIGURE 1-1: K-SERIES PRIVATE LIFT COMPONENTS

32DSSK04.A

TABLE 1-1: K-SERIES WHEELCHAIR LIFT TERMS

TERM	DESCRIPTION
Left	Lift references when installation is viewed from outside of vehicle.
Right	
Front	
Rear	
Armrest	(left and right) Provides handhold for passenger.
Armrest switch	Allows passenger to control “Up” and “Down” platform motions.
Audible alarm	Announces when something has passed over threshold. Activated by threshold beam.
Baseplate	Assembly that is securely bolted to the vehicle floor.
Bridgeplate (inboard rollstop)	Plate that bridges gap between platform and lift baseplate when platform is at floor level. Also acts as a rear rollstop when platform is in motion.
Bridgeplate load sensor	Senses when weight is present on the lowered bridgeplate.
Control pendant	Hand-held device used to control the lift operating functions.
Cycle counter	Visible at top rear of housing, it records number of times platform has moved from floor to ground and back to floor.
Front platform section	Portion of platform that unfolds during “deploy” operation and folds during “stow” operation.
Front rollstop	Front barrier prevents wheelchair from slowly or inadvertently rolling off of platform during lift operation.
Hydraulic cylinder	(left and right) Telescoping steel tube, which converts hydraulic pressure into lifting force.
Hydraulic power unit	Contains electric motor driven pump that produces hydraulic pressure to raise and fold platform, and a pressure release valve to unfold and lower it. Also contains a manually operated backup pump for use when normal power is not available.
Manual backup pump handle	Used to operate manual backup pump.
Platform folding linkage	(left and right) Links that cause front platform section to unfold as it deploys or fold as it stows.
Platform hinges	Three hinges, welded to bottom side of platform, join front and rear platform sections together.
Platform hinges	Three hinges provide connection between front and rear platform sections.
Rear platform section	Rear portion of platform that is folded by linkage located within the vertical arms.
Serial number	Location of lift serial number decal.
Stow lock catch	Engages latch on bottom of bridgeplate when platform is fully stowed.
Threshold bams	Light beams detect presence of objects in threshold area.
Top and bottom arms	(left and right) upper and lower links that connect vertical arms to baseplate.
Vertical arm	(left and right) Connects platform to top and bottom arms.
END OF TABLE	

This page intentionally left blank.

II. INSTALLATION

This chapter contains instructions for installing the RICON K-Series Private Use wheelchair lift into most vans, although custom installations are also possible in other types of vehicles. Due to the wide range of lift applications, specific information for every possible application is not available. The following general procedures will apply to most installations. Contact the Ricon Product Support department for instruction on installations not covered. To install lift, refer to following sections and perform procedures carefully and in the order that they are presented. Be certain that installation instructions are followed exactly and do not eliminate any steps or modify product.

NOTE: Please review carefully the installation instructions (32ii370e) that are supplied with this lift before beginning the following procedures. Where these procedures conflict, the installation instructions take precedence.

A. GENERAL MECHANICAL INSTALLATION

1. LIFT LOCATION

The installation surface must be flat and level. It is recommended that lift be installed on a ½", minimum, high-grade plywood sub-floor. However, this additional installation height may not be acceptable in cases where overhead clearance is limited.

NOTE: Check for proper travel clearance through doorway.

- With doors fully open, place/position lift in vehicle doorway as close as possible to door, with lift's baseplate assembly parallel to side of vehicle.
- Allow a distance of ¾", if possible, between door and the part of lift closest to it. Adjust lift left and right-side locations to accommodate subframe members.
- Verify proper clearance of door frame, passenger seats, and outer edge of vehicle floor and possible interference with wires, fluid lines, subframe members, etc.

2. LIFT INSTALLATION GUIDELINES

The lift mounting is a very important step. Improper mounting or fastening of baseplate can adversely affect lift performance. Although fastening details may vary from one vehicle to the next, these general principles apply:

- Be certain that all mounting bolts are properly installed and tightened. Bolts used to fasten baseplate assembly to vehicle floor must have a minimum strength rating of SAE Grade 5 and be torqued to 28 ft lbs, dry. Recognize that the most important bolts are those along the rear of lift, since these bolts retain the majority of the load.
- Refer to **Figures 2-1** and **2-5**. Improper torquing sequence of baseplate bolts may result in a warped or bowed baseplate, which can cause platform to move erratically.

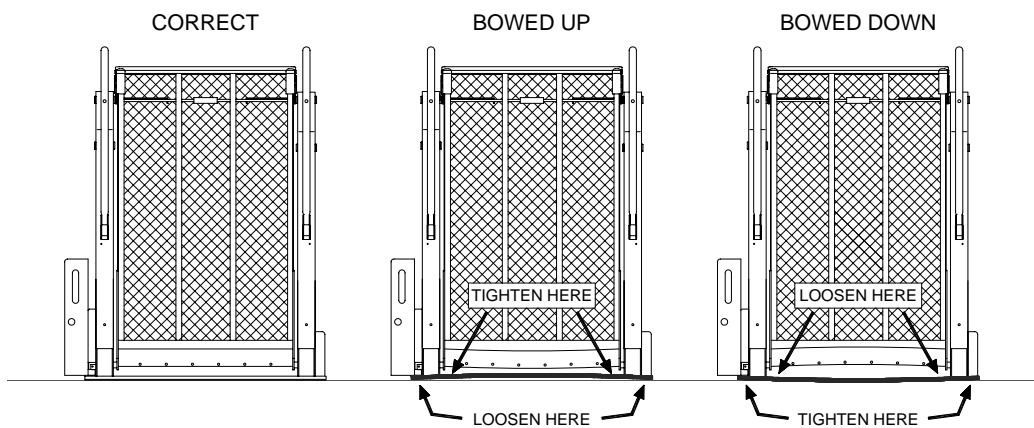

FIGURE 2-1: EXAMPLES OF BASEPLATE WARPAGE

- ◆ Refer to **Figure 2-2**. On Ford van installations, clamping bars are used to help evenly distribute floor loading and should only be cut if needed to clear a subframe member. A subframe member must be used to support clamping bar.

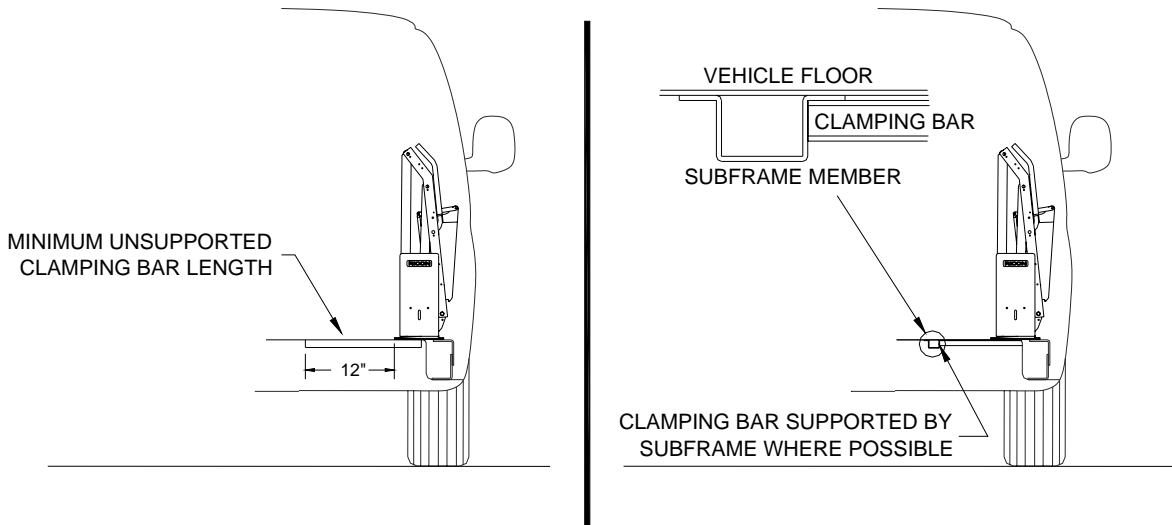

FIGURE 2-2: FORD VAN CLAMPING BAR ARRANGEMENT

3. LIFT INSTALLATION INTO VANS

This is a general procedure for installing Ricon lifts into Ford, Dodge, and Chevrolet full size vans.

- Refer to **Figure 2-3**. Use four 1" x 3/8" bolts, 3/8" washers, 3/8" lock washers, and 3/8" hex nuts to assemble two bracket assembly kits.

NOTE: The top bracket must overlap bottom bracket, and both slots must face outward.

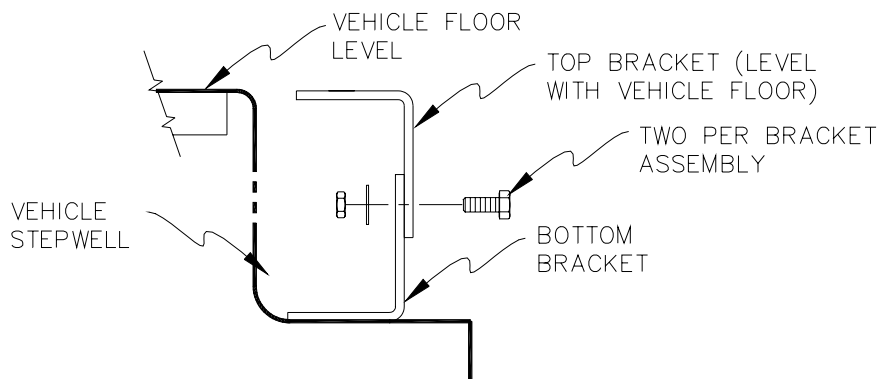

FIGURE 2-3: STEPWELL BRACKET

- Position brackets on stepwell and adjust height of both bracket assemblies so that top bracket is level with vehicle floor. Tighten bracket assembly bolts.
- Verify that lift is fully folded (stowed) with handrails folded tight against vertical arms. If necessary, use manual pump.



WARNING

LIFT WEIGHT IS APPROXIMATELY 340 - 370 LBS. USE EXTREME CARE WHEN POSITIONING BECAUSE STEPWELL BRACKETS MAY TIP. THIS PROCEDURE MUST NOT BE ATTEMPTED BY ONE PERSON.

- d. Refer to **Figure 2-4**. With doors fully open, position lift in vehicle doorway so that back of lift is supported by vehicle floor, and front of lift is supported by both bracket assemblies.

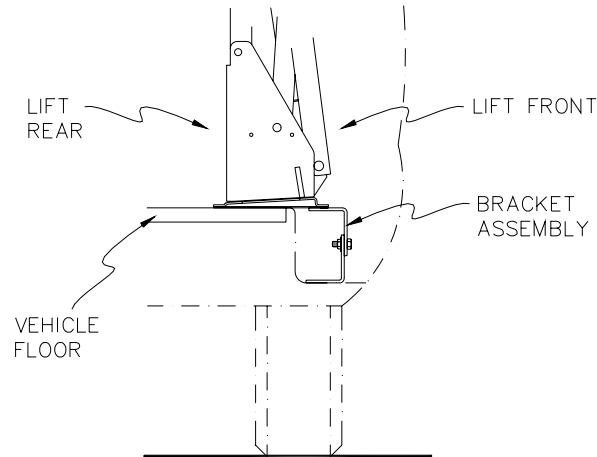

FIGURE 2-4: BRACKET ASSEMBLY

- e. Fasten Baseplate to Floor:

NOTE: If Ricon power door operators are used, install them first. They may influence location of lift.

- * Be certain baseplate is flush against vehicle floor. The baseplate may be slightly offset in door opening to provide proper clearance for passenger seats.
 - * Before drilling, verify that lift position does not interfere with closing of vehicle doors or operation of passenger seats.
 - * If this lift is being installed in a Dodge van with sliding doors, omit the bolts in baseplate holes 7 and 8.
- f. Mark and Drill Holes:

CAUTION

Before drilling holes, verify that underlying wires and tubing will not be damaged.

- 1) Refer to **Figure 2-5**. Mark and drill five 25/64" baseplate mounting holes (1, 2, 3, 4, and 5) through vehicle floor. (On Dodge and GM vans, you must drill through vehicle floor and subframe).
- 2) Place five 8" x 3/8" carriage bolts (use 4" x 3/8" bolts on Ford vans) into holes to secure position.

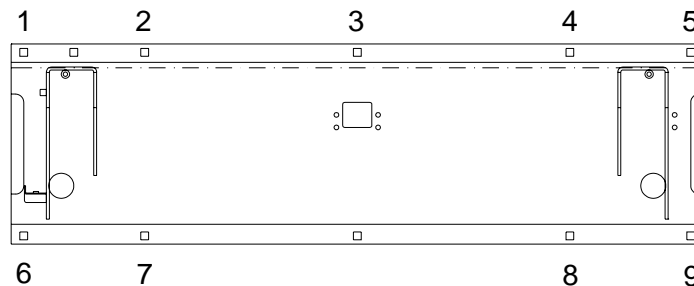

FIGURE 2-5: VAN BASEPLATE HOLES

- 3) Refer to **Figure 2-6** on the following page. Match and align top holes of stepwell brackets 6, 7, 8, and 9, with baseplate holes 6, 7, 8, and 9. Mark lower stepwell bracket holes 10, 11, 12, and 13 onto vehicle step.
- 4) Remove five carriage bolts installed in step 2). Carefully push lift into vehicle interior.
- 5) Drill 1/4" dia holes through marked locations 10, 11, 12, and 13.

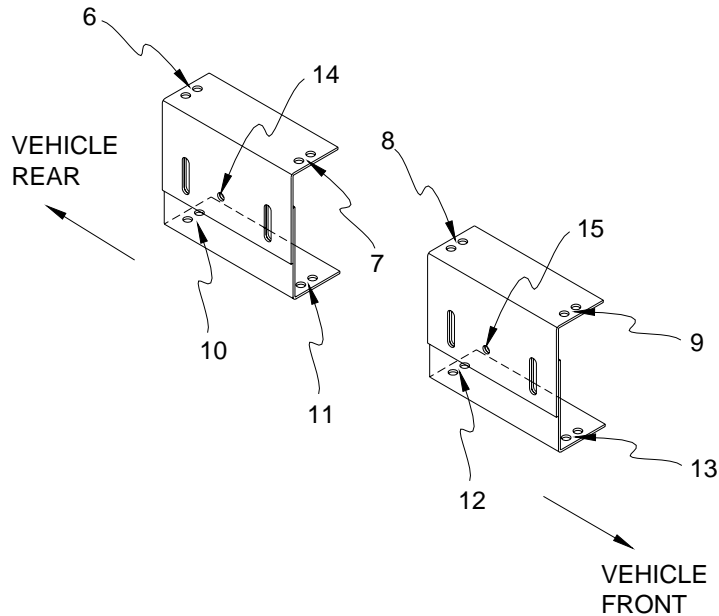

FIGURE 2-6: STEPWELL BRACKET HOLE LOCATIONS

g. Fasten Bracket Assemblies and Lift:

- 1) Use 1-1/2" x 5/16" sheet metal screws with 5/16" lock washers to secure lower brackets to vehicle step holes 10 through 13.

NOTE: If the screw in position 13 interferes with proper door operation, do not install.

- 2) Reposition lift and verify that surface beneath lift is free of obstacles.
- 3) Insert five 8" x 3/8" carriage bolts through mounting holes at rear of baseplate assembly, and insert four 1-1/2" x 3/8" carriage bolts through baseplate and bracket assemblies. Place 3/8" washers, lock washers, and nuts under bracket assemblies, and finger tighten nuts.

NOTE: On Dodge and GM vans, place five 4" x 4" plates, 3/8" washers, lock washers and hex nuts on 8" x 3/8" carriage bolts under van and finger tighten. On Ford models, reinforce vehicle floor with clamping bars. They are installed in positions 1, 2, 3, 4, and 5 and run across width of baseplate towards center of van.

- 4) Before tightening carriage bolts, verify that lift is level with vehicle floor. Adjust bracket assembly bolts if necessary.
- 5) Tilting lift towards inside of van may hinder its initial unfolding. Install lift with its baseplate assembly as level as possible. Tightening carriage bolts requires special care to keep baseplate assembly from warping when secured to vehicle floor. If baseplate assembly warps, the vertical arms will not be parallel. Make corrections by shimming at appropriate locations. To help prevent warping, tighten the eight carriage bolts (six on Dodge van with sliding door) to 28 ft. lbs. in the appropriate sequence:

DODGE WITH SWING DOORS, ALL FORD AND GM VANS **3, 1, 2, 4, 5, 6, 7, 8, 9**

DODGE WITH SLIDING DOORS **3, 1, 2, 4, 5, 6, 9**

NOTE: Vertical arms must be parallel for proper operation. Adjust bolts as required. Best results are obtained when lift is mounted on plywood. Shims, although best avoided, may be used if required.

- 6) Make certain that holes 14 and 15 on the front of each bracket assembly are drilled through, and 5/16" bolts are inserted to lock position of bracket assemblies.

B. ELECTRICAL INSTALLATION

CAUTION

- Do not route a wire if it is connected to the battery.
- Route wires clear of moving parts, brake lines, and the exhaust system. Secure to the vehicle.
- When routing an electrical wire through vehicle floor or walls, use a grommet to protect wires from chafing.
- Check underside of vehicle before drilling to avoid damage to fuel lines, vent lines, brake lines, or wiring.

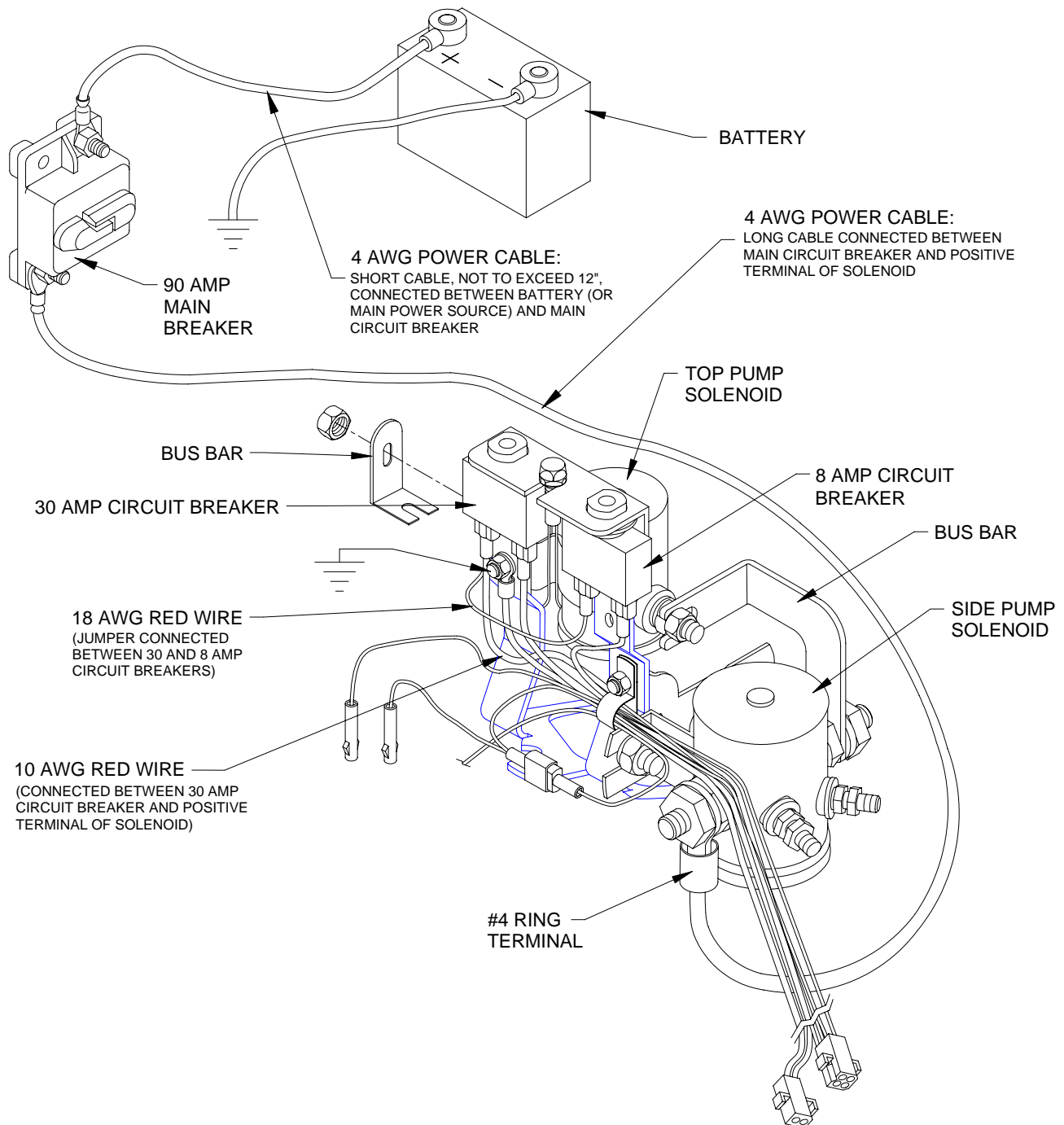

FIGURE 2-7: ELECTRICAL INSTALLATION DIAGRAM

1. INSTALL MAIN CIRCUIT BREAKER

- a. Disconnect battery.
- b. Mount main circuit breaker inside engine compartment within 12 inches of battery (to minimize length of unprotected cable). Avoid installing near a heat source.

2. ROUTE AND CONNECT MAIN POWER CABLE



CAUTION

Check under-side of vehicle before drilling to avoid damage to fuel lines, vent lines, brake lines, or wiring.

NOTE: For applications where power cable is to pass through sheet metal, drill a 3/4" hole and use wire clamp provided. For applications where cable is to pass through plywood, drill a 1" hole and use black plastic grommet provided.

- a. Refer to **Figures 2-7 and 2-8**. Drill a hole through vehicle floor near or under pump solenoids so power cable can reach positive stud of side solenoid (the stud on side solenoid that is not connected to top solenoid with a bus bar). Drill hole where the installed pump cover will cover it.

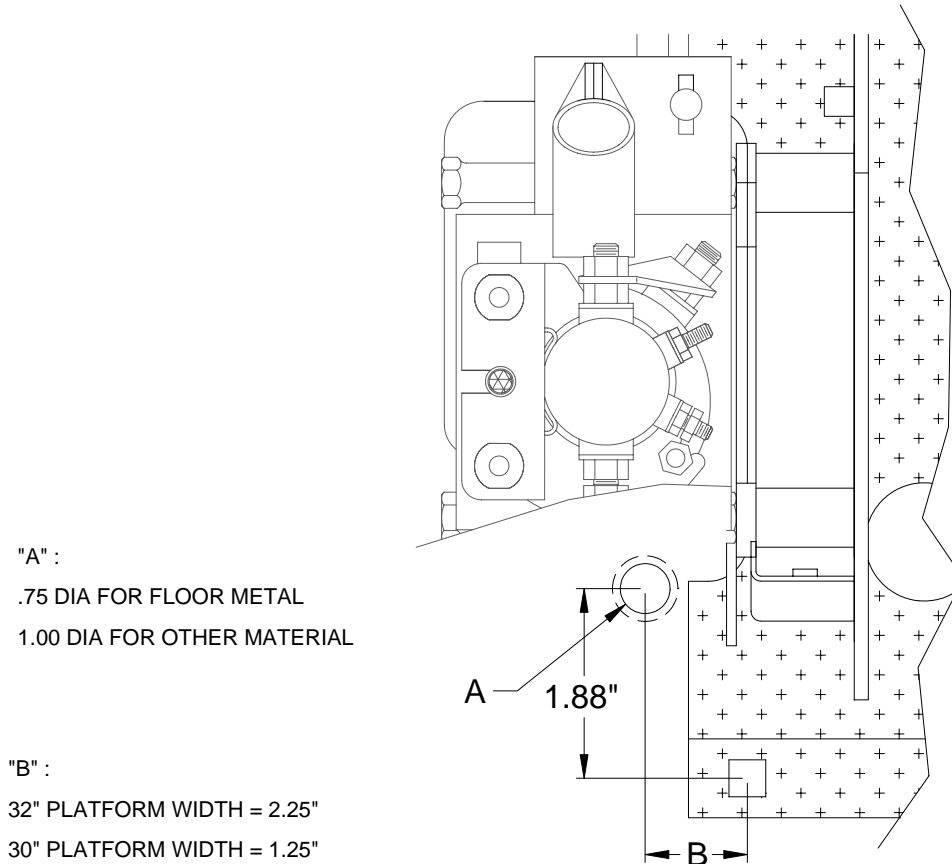

FIGURE 2-8: POWER CABLE ACCESS HOLE

- b. Install supplied heavy ring terminals to each end of the short (12" long) 4 AWG power cable and set aside. Install one ring terminal, only, to one end of long power cable. Use an appropriate crimp tool (such as Ricon hammer tool, part of kit P/N 01243).
- c. Connect ring terminal end of long 4 AWG power cable to 90A main circuit breaker, then route power cable underneath vehicle floor and up through hole in floor.
- d. Tie power cable to vehicle chassis, and to pump assembly harness using cable ties. Avoid pinch points, exhaust system, moving parts, and brake lines. Verify that power cable is secure.



CAUTION

Be sure that there is no interference with any parts that could damage power cable or other wires in any way.

- e. Refer to **Figure 2-9**. Cut excess wire from long cable, install heavy ring terminal, and then connect to side solenoid. Verify that red wire from main circuit breaker (if applicable) is connected to positive solenoid pole.

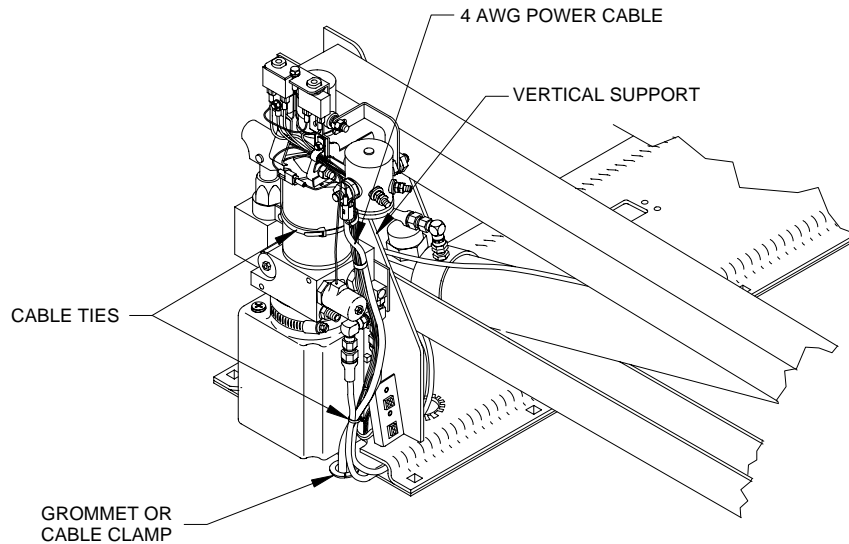

FIGURE 2-9: CABLE ROUTING

- f. Connect 12" cable, with ring terminals, from positive battery terminal to main circuit breaker terminal.

3. CONNECT CONTROL PENDANT

- a. Refer to **Figure 2-10**. Connect hand-held control pendant to six-pin connector at left side of baseplate and secure cable with supplied bracket and cable clamps.

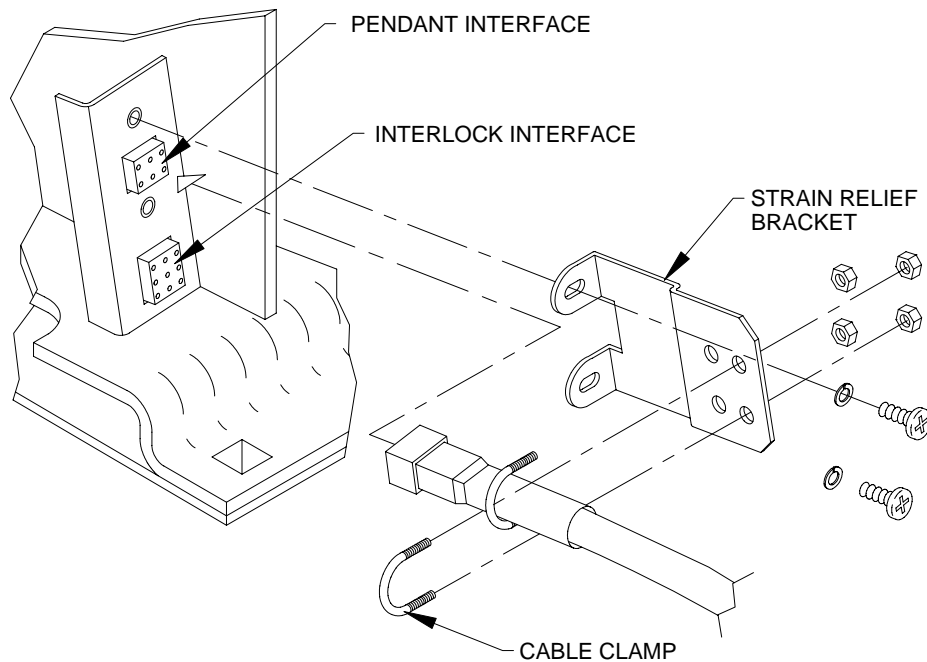

FIGURE 2-10: STRAIN RELIEF KIT

- b. Install wall portion of dovetail clip (pendant storage) in an appropriate and safe location near lift.

CAUTION
Be sure that harness does not interfere with any moving parts, or binds against any parts, or is pinched in any way.

4. GROUND (COMMON) CONNECTIONS

a. 12VDC Systems

12VDC powered lifts are chassis grounded and do not require a separate ground cable connection to battery. However, if the common side of the lift electrical system is connected to chassis with a cable, the cable must be attached in a manner that provides a reliable electrical connection. If ground cable is attached to an existing ground circuit, the circuit must be capable of conducting an additional 90 amps.

b. 24VDC Systems

- 1) Ricon recommends that a dedicated ground cable be used in 24VDC installations. A 4GA cable, or heavier, must be used.
- 2) Refer to **Figure 2-11**. The ground cable is connected from the negative stud (-) on pump motor to the negative battery terminal.

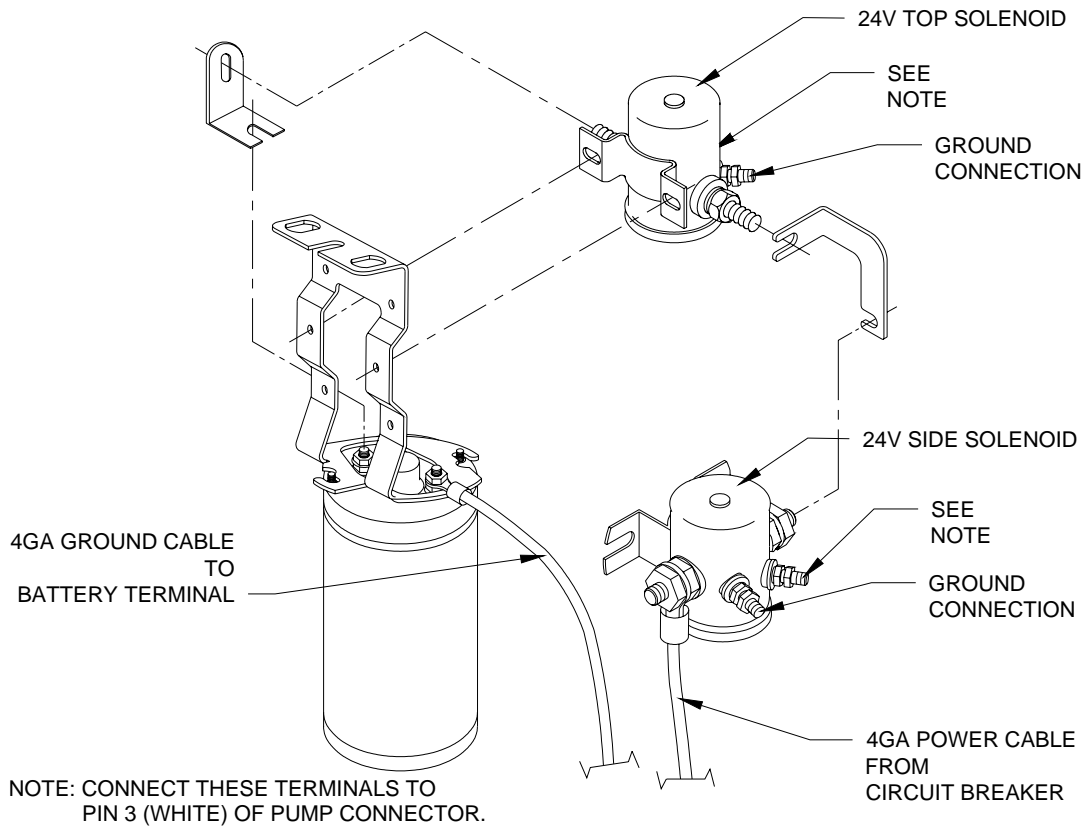

FIGURE 2-11: 24VDC DUAL SOLENOID WIRING

5. INSTALLATION OF INTERLOCK DEVICE

The supplied interlock device must be installed to prevent operation of the lift or vehicle when it is unsafe to do so. The K-series lift provides an electrical interlock signal to the vehicle that prevents movement of the vehicle unless the platform is fully stowed. The interlock control also supplies power to the lift only when the vehicle parking brake is set and the transmission is in PARK.

NOTE: An 8-amp circuit breaker is located within the lift as a circuit protection device. The circuit interface used by the installer must be capable of carrying an additional 8 amps of continuous current.

Refer to **Figure 2-12**. The interlock installation kit provides a display panel for mounting on the vehicle dashboard. The figure shows an LED display panel. The Lift Power LED lights green when the vehicle transmission is in PARK and the parking brake is set. While the LED is green the lift is lowered and the platform can be deployed. The Not Stowed LED lights red when the platform is not fully stowed into the vehicle. While the LED is red the transmission cannot be shifted out of PARK.

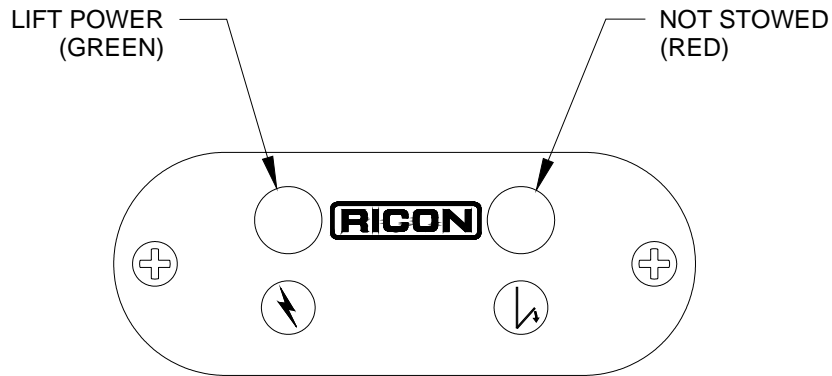

FIGURE 2-12: INTERLOCK DISPLAY PANEL

The installer must verify that none of the original equipment circuit breakers, fuses, or solenoids are bypassed, removed, or altered. Be sure that no wires are left frayed or hanging loose after installation of the interlock device. If you have any questions concerning the proper installation of this interlock device, please contact our Product Support department.

C. FINAL ADJUSTMENTS

1. LIMIT SWITCH ADJUSTMENT

Refer to **Figures 2-13, 2-14**, and the following procedure.

NOTE: To avoid operational “dead-spots”, adjust **DEPLOY CUTOFF SWITCH** before **UP CUTOFF SWITCH**.

NOTE: When loosening adjustment screws, apply enough pressure to screw to move block instead of screw. (The block might stick if insufficient pressure is applied to screw.)

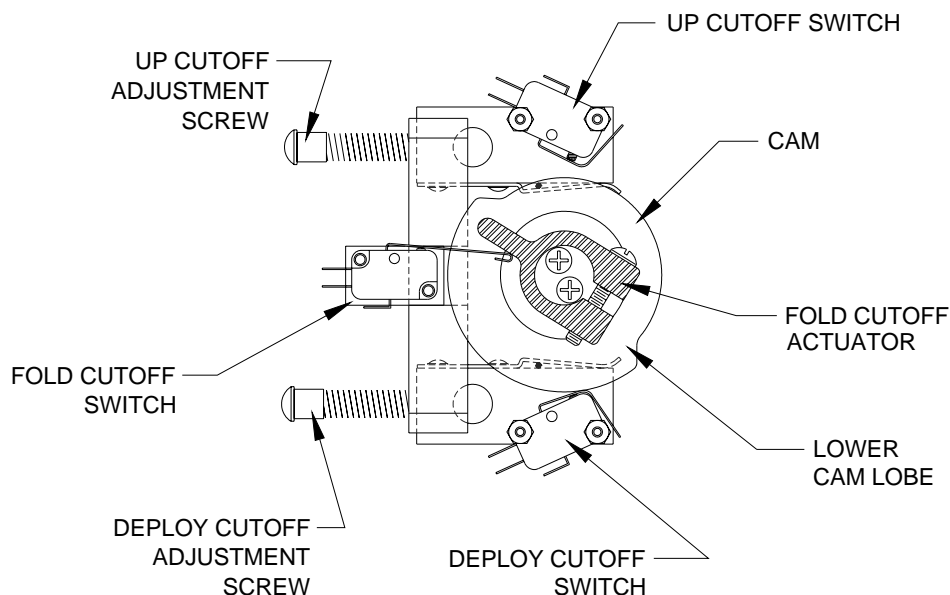

FIGURE 2-13: LIMIT SWITCH ADJUSTMENT DIAGRAM

32DSSK04.A

- a. Fully DEPLOY platform.
- b. Adjust UP CUTOFF ADJUSTMENT SCREW and DEPLOY CUTOFF ADJUSTMENT SCREW 6-8 turns **counterclockwise** and then push screws FORWARD.
- c. Cycle platform to STOW then DEPLOY.
- d. When in DEPLOY position, platform should stop at an angle and NOT even with vehicle floor. If not, turn DEPLOY CUTOFF ADJUSTMENT SCREW an additional 2-3 turns **counterclockwise**, push screw forward, STOW then DEPLOY platform, then repeat this step.
- e. Cycle platform to UP position.
- f. When in UP position, platform should stop short of vehicle floor level. If not, turn UP CUTOFF ADJUSTMENT SCREW an additional 2-3 turns **counterclockwise**, push screw forward, cycle platform DOWN then UP, then repeat this step.
- g. Cycle platform to STOW then DEPLOY.
- h. Push and hold control pendant DEPLOY switch. Slowly turn DEPLOY CUTOFF ADJUSTMENT SCREW **clockwise** until platform “jogs” down to vehicle floor level. Make sure that clearance between knuckle actuator saddle and parallel arm is 1/8" minimum (distance may be 1/2" maximum and unequal from left or right arm), stop turning screw and release DEPLOY switch.

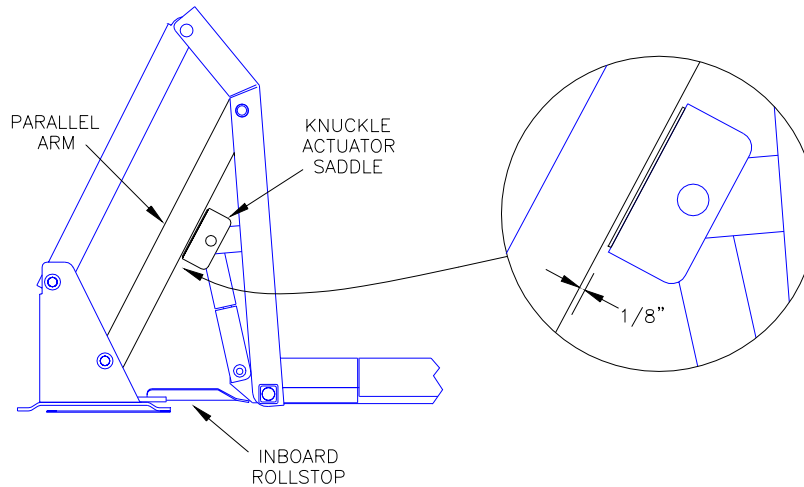

FIGURE 2-14: LIMIT SWITCH ADJUSTMENT CLEARANCE

- i. Position platform DOWN to ground level then UP until it stops.
- j. Push and hold control pendant UP switch. Slowly turn UP CUTOFF ADJUSTMENT SCREW **clockwise** until platform “jogs” up to vehicle floor level. Make sure that clearance between knuckle actuator saddle and parallel arm is 1/8" minimum (distance may be 1/2" maximum and unequal from left or right arm), stop turning screw and release UP switch.

NOTE: If lift does not operate after 1-2 full turns of adjustment screw, cycle platform UP and DOWN (The UP CUTOFF SWITCH is less sensitive than DEPLOY CUTOFF SWITCH.)

- k. Cycle platform through all functions (DEPLOY, DOWN, UP, and STOW) to verify correct adjustment. Refer to **Table 2-1** if necessary.

TABLE 2-1: LIMIT SWITCH ADJUSTMENT CHART			
COMPONENT	SYMPTOM	CORRECTIVE ACTION	ADJUSTMENT PROCEDURE
Fold cutoff actuator	Lift does not fold tightly.	Rotate actuator counter-clockwise.	With lift fully folded (handrails should be folded tight against vertical arms), rotate actuator so that it barely trips fold cutoff switch.
	Pump runs continuously.	Rotate actuator clockwise.	Test lift. Pump should cutoff when lift is folded tight.

TABLE 2-1: LIMIT SWITCH ADJUSTMENT CHART			
COMPONENT	SYMPTOM	CORRECTIVE ACTION	ADJUSTMENT PROCEDURE
Up cutoff adjustment screw	Lift stops low.	Adjust screw clockwise.	Adjust up cutoff switch so that lift stops just before first knuckle actuator saddle or roller touches underside of lower parallel arm. (Saddle or roller should be about 1/8" from lower parallel arm.)
	Lift stops high.	Adjust screw counter-clockwise.	
Deploy cutoff adjustment screw	Lift stops low.	Adjust screw counter-clockwise.	Adjust deploy limit switch so that lift stops just below "Up" cutoff described in above step. This will give the necessary overlap to avoid "dead" spots.
	Lift stops high.	Adjust screw clockwise.	
END OF TABLE			

2. PLATFORM TILT ADJUSTMENT

Correct platform tilt adjustment is crucial for proper platform rollstop operation, but cannot be adjusted at factory. Factors such as vehicle floor height, lift tilt angle and stiffness of vehicle springs will vary installation geometry.

- a. Deploy and lower lift platform to a position halfway between vehicle floor level and ground level.
- b. Refer to **Figure 2-15**. Adjust left and right platform set screws until platform is level at zero (0) degrees. Turn setscrews clockwise to angle front-end of platform upward, or counter-clockwise to angle downward.

NOTE: At ground level, the distance between heel of platform and ground should be 3/4" to 1". This distance should be measured at initial point of rollstop full deployment.

NOTE: Adjust setscrews on both sides of platform simultaneously and evenly to ensure proper leveling of platform.

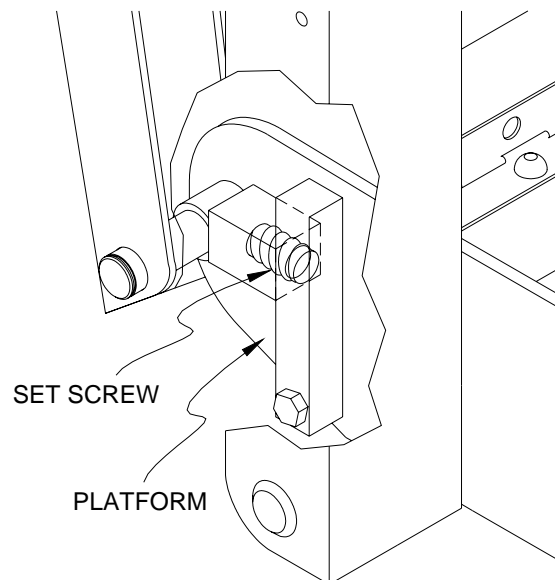

FIGURE 2-15: PLATFORM SET SCREWS

- c. Repeat steps a and b as required to achieve proper rollstop operation.

 **CAUTION**

Do not lengthen tie rod stud to point where panel will lift off its tab support (at center of lift fork).

- d. Adjust left tie rod assembly. Adjust tie rod stud until nearly all of link free-play is out by lengthening rod.

3. PLATFORM FOLDING LINKAGE ADJUSTMENT

The front portion of the platform is connected to the rear portion with a hinge. The front portion is folded with linkages located at the right and left sides of the platform. The length of the linkage might require adjustment after installation of the lift or after disassembly of the platform.

NOTE: Perform the PLATFORM TILT ADJUSTMENT procedure (in previous section) before adjusting the linkage.

- 1) Deploy and lower the platform to a position about halfway between floor level and ground level.
- 2) Refer to **Figure 2-16**. Loosen the jam nuts (right and left sides) and use the adjusters to set the length of the linkages so that the front and rear portions are in the same plane; the two surfaces of the platform portions must be flat without any apparent folding along the hinge. Verify that the tension of both linkages is the same by sighting along outer edge of the platform (arrow in figure). Tighten jam nuts.

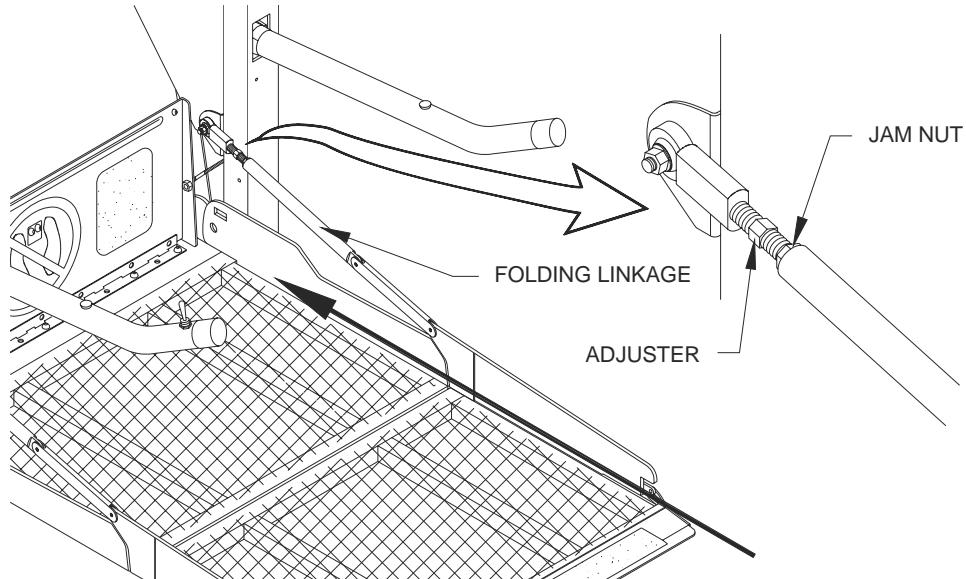

FIGURE 2-16: ADJUSTMENT HARDWARE FOR PLATFORM FOLDING LINKAGE

- 3) Lower platform until it settles on the ground. Verify that a slight amount of slack is present in both linkages. If either linkage is under tension, repeat steps a and b.

4. PLATFORM PRESSURE SWITCH CHECK AND ADJUSTMENT

Correct adjustment of this pressure switch will prevent platform from folding into vehicle when there is a load of 50 lbs, or more, on the platform.

- a. Refer to **Figure 2-17**. Deploy and lower platform to ground. Place a 50 lb. load in center of platform and then raise platform to floor level. Press and hold STOW switch.

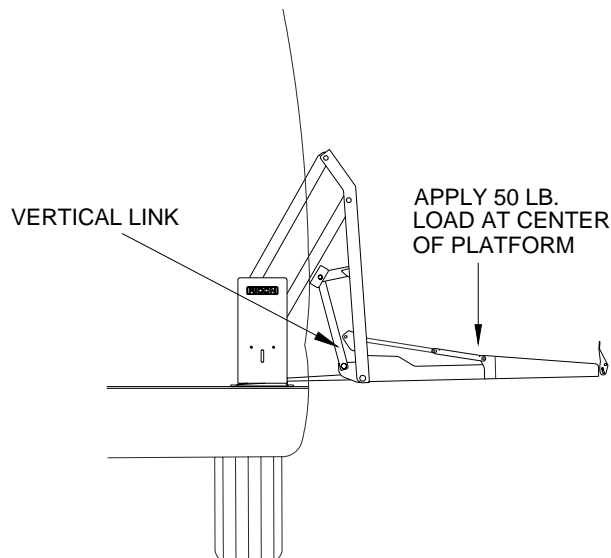

FIGURE 2-17: PRESSURE SWITCH TEST AT FLOOR LEVEL

- b. The pressure switch is correctly set if pump motor shuts off, preventing inward movement of platform. There should not be excessive on/off clicking of pump motor that would indicate switch is marginally set. Proceed to next step if pump motor does not shut off.
- c. Refer to **Figure 2-18**. Remove the 1/4-20 x 1.00" setscrew (with hex recess) from end of pressure switch to gain access to adjustment screw. Save setscrew for reinstallation.

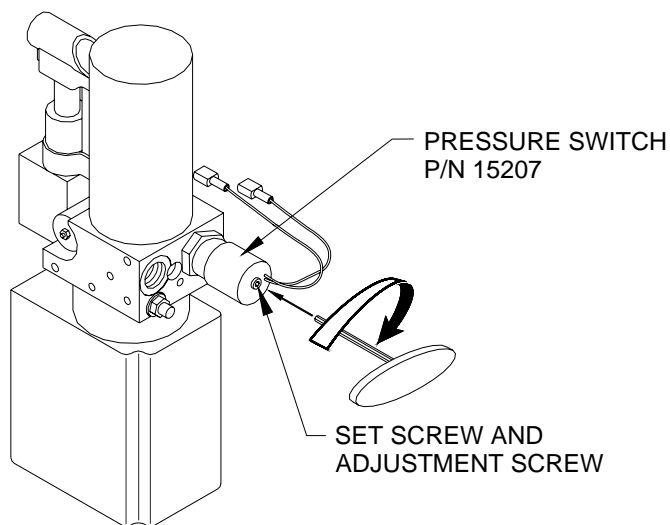

FIGURE 2-18: HYDRAULIC PUMP WITH PRESSURE SWITCH

- d. Insert a 1/8" hex wrench into pressure switch and engage adjustment screw inside. Turn screw 1/8 turn clockwise, and then repeat 50 lb. load check described above. Repeat adjustment, as necessary, to achieve correct setting.
- e. Reinstall setscrew and tighten against adjustment screw.

D. VERIFY INSTALLATION

- Be certain that no vehicle components interfere with operation of lift.
- The lift is designed to carry the weight of a wheelchair and its passenger. The vehicle structure must be capable of supporting all loads produced during lift operation as well as those forces caused by motion of vehicle when it is driven.



CAUTION

- Do not operate lift when test weight is on platform. This load test is designed to test the lift **mounting method**, not the lift capacity. Remove test weight immediately after check.
 - Vehicle suspension will compress and vehicle will lean when test weight is placed on platform. If weighted platform contacts ground, remove weight, raise platform, and retest.
- Ricon recommends that the lift be test loaded at its rated 600 pound load capacity to verify integrity of installation. Position lift platform 2" - 6" above the ground, place 600 pounds in center of platform, and inspect lift mounting brackets and hardware. REMOVE TEST WEIGHT.
 - Run lift through several complete cycles while checking for proper operation.
 - Refer to **Figure 2-19** on next page and verify that all decals are properly located and affixed as shown.

NOTE: The installing dealer affixes an Operating Instructions decal to vehicle in a location clearly visible to the lift operator.

E. CUSTOMER ORIENTATION

IMPORTANT

- Customer Orientation -

Ricon Sales or Service personnel must review the warranty card and Operator manual with the customer to be certain they understand how to safely operate the lift. The customer should be instructed to follow the operating instructions without exception.

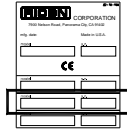
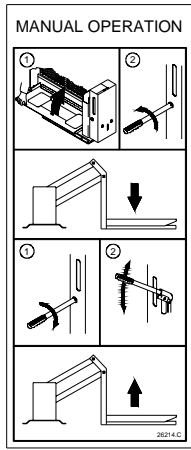

PART OF SERIAL NUMBER DECAL (LOCATED ON INNER SIDE OF HYDRAULIC CYLINDER; ONLY RICON REPLACEABLE)



PART OF SERIAL NUMBER DECAL (ONLY RICON REPLACEABLE)

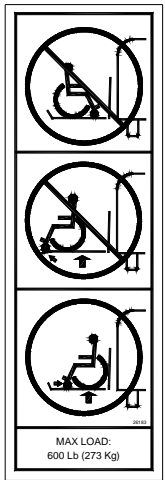

MAXIMUM LOAD
PN 26183
MAX LOAD:
600 Lb (273 Kg)

MANUAL OPERATION
PN 26214

PUMP COVER
PN 26292



DOT - Private Use Lift

DOT-PRIVATE
USE LIFT
PN 32141

K-SERIES
PATENT NO.
PN 19518



RICON LOGO
(BOTH SIDES)
PN 32-10-152

K-SERIES PRIVATE USE WHEELCHAIR LIFT

WARNING:
Improper use of lift can result in personal injury. User must read and follow operating instructions in Operator Manual. Additional copies of Operator Manual are available from:
RICON CORPORATION
7900 NELSON ROAD
PANORAMA CITY, CA 91402
(800) 322-3888
(818) 267-3000

2) Do not exceed rated load.
3) Inspect wheelchair lift for damage, correct lift functions, and required maintenance prior to use. Do not use lift if problem exists, and send to an authorized service technician for repair.
4) This lift is designed for use by wheelchair occupants only. **DO NOT USE FOR STANDING PASSENGERS.**
Ricon Corporation disclaims liability for damage or personal injury resulting from lift modification, lack of maintenance, faulty repair, negligence, abuse, or failure to follow lift operating instructions.

OPERATING INSTRUCTIONS:
(Also read Operator Manual)

Deploy Lift:
1) Check doors fully. Power doors open automatically when DEPLOY button is actuated. Lift will unfold and stop at vehicle floor level.
2) Use pendant switch to apply power to platform.
3) Press and hold DEPLOY button to unfold platform and lower it to vehicle floor level.
4) Press and hold DOWN button to lower platform to ground level.

Enter Vehicle:
1) Proceed to center of platform, and face forward. If possible, LOCK WHEELCHAIR BRAKES.
2) Press and hold UP button to raise platform to vehicle floor level.
3) Release wheelchair brakes and enter vehicle.

Exit Vehicle:
1) Proceed to center of platform, and face forward. If possible, LOCK WHEELCHAIR BRAKES.
2) Press and hold DOWN button to lower platform to ground level.
3) Release wheelchair brakes and exit platform.

Stow Lift:
1) Press and hold STOW button to fold platform and return to stowed position.
2) Turn pendant switch off.
3) Close doors.

MANUAL OPERATION:
See Manual Operation instructions in Operator Manual or on pump cover.

CAUTION:
Safety pins vehicle before using lift. Keep others clear of lift when it is in motion. Position wheelchair in center of platform to prevent interference with outer rollover when it folds.

32143.1

PRIVATE USE
OPERATING
INSTRUCTIONS
PN 32143

DECAL REFLECTIVE,
RED AND WHITE
(BOTH SIDES)
PN 33011

FIGURE 2-19: PRIVATE LIFT DECAL LOCATIONS AND PART NUMBERS

This page intentionally left blank.

III. MAINTENANCE AND REPAIR

Regular maintenance of the Ricon KlearVue K-series Private Use wheelchair lift will optimize its performance and reduce the need for repairs. This chapter contains lubrication and cleaning instructions, a maintenance schedule, troubleshooting section, and maintenance diagrams.

⚠ CAUTION

This Ricon product is highly specialized. Maintenance and repairs must be performed by an authorized Ricon service technician using Ricon replacement parts.

A. LUBRICATION

⚠ CAUTION

Do not lubricate motor or other electrical components. Lubrication of electrical components may collect dirt and debris, causing short circuits.

Lubrication should be performed at least every six months or sooner depending on usage. Refer to **Figure 3-1** and the following Maintenance Schedule. Lubricate lift at points indicated with lubricants specified.

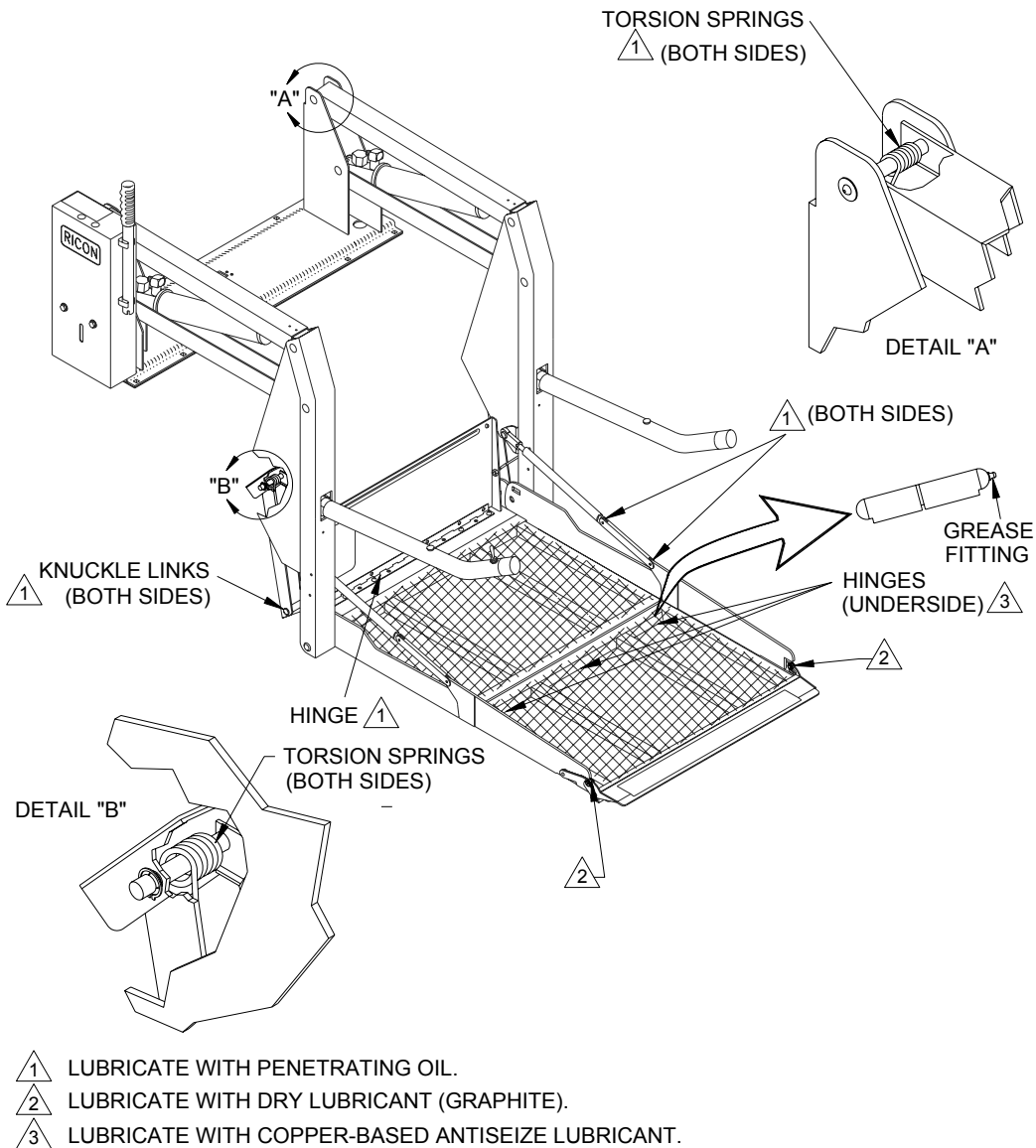



FIGURE 3-1: LIFT LUBRICATION POINTS

B. CLEANING

Regular cleaning with mild soap (i.e. hand soap, car wash liquid) and drying thoroughly will protect lift painted surfaces. Cleaning is especially important in areas where roads are salted in winter. Make sure that lift pivot points remain clear and clean prior to lubrication.

C. MAINTENANCE SCHEDULE

Under normal operating conditions, maintenance inspections are required at least every six months (1750 cycles) and a thorough inspection should be performed at service intervals referenced in **Table 3-1**. Service should be increased under conditions of heavy use (more than 10 cycles per day.)

TABLE 3-1: MAINTENANCE SCHEDULE	
SERVICE POINT	ACTION TO PERFORM
10 CYCLES	
Overall condition	Listen for abnormal noises as lift operates (i.e. grinding or binding noises.)
Control pendant	Verify that control pendant is undamaged and cable connector is tight.
150 CYCLES	
Electrical wiring	Inspect electrical wiring for frayed wires, loose connectors, etc.
Vehicle interlock	Place vehicle in non-interlock mode and verify that lift does not operate.
Decals	Verify that lift decals are properly affixed, clearly visible, and legible. Replace, if necessary.
Armrests	Verify that armrest fasteners are properly tightened.
Lift mounting points	<ul style="list-style-type: none"> ▪ Verify that vehicle mounting and support points are undamaged. ▪ Verify that mounting bolts are sufficiently tight and free of corrosion.
Main lifting pivots	Verify that link pins on arms are properly installed, free from damage, and locked in position.
Platform pivot points	Verify that platform moves freely, without binding, and does not wobble.
Bridgeplate	<ul style="list-style-type: none"> ▪ Verify that bridgeplate operates without binding during lift functions. ▪ Verify that bridgeplate deploys fully when platform stops at floor level. ▪ Verify bridgeplate rests flat against baseplate.
Front rollstop	<ul style="list-style-type: none"> ▪ Verify that rollstop is opened completely when platform is at ground level. ▪ Verify that rollstop closes and locks when platform leaves ground.
Hydraulic power unit	 CAUTION
	Check and add fluid when platform is at ground level. Fluid that is added when platform is raised will overflow when platform is lowered.
	<ul style="list-style-type: none"> ▪ Verify that pump hydraulic fluid level is at FULL mark when platform is at ground level. Add Texaco 01554 Aircraft Hydraulic Oil or equivalent U.S. mil spec H5606G fluid. ▪ Verify there are no hydraulic fluid leaks. ▪ Verify that manual backup pump operates properly.
1800 CYCLES	
Cleaning and lubrication	<ol style="list-style-type: none"> 1. Clean lift with mild soap and water and wipe dry. Prevent rust by coating all surfaces with a light weight oil. Remove excess oil. 2. Spray penetrating oil (Curtisol® Red Grease 88167 or WD-40®) where specified following directions on container. Remove excess grease from surrounding areas.
 CAUTION	
A Ricon authorized dealer must perform the following safety check.	
3600 CYCLES	
Hydraulic cylinder, hoses and fittings	<ul style="list-style-type: none"> ▪ Check hydraulic cylinder for evidence of leaks. ▪ Inspect hydraulic hoses for damage. ▪ Verify that all fittings are tight.
END OF TABLE	

D. TROUBLESHOOTING

The troubleshooting guides are designed to provide logical starting points to locate general problems that could occur with lift. However, not all possible problems or combinations of problems are listed. For troubleshooting lift, refer to **Table 3-2**. The guide does not incorporate routine safety precautions or preliminary procedures, and assumes that vehicle battery is fully charged and battery terminals/connectors are clean and tight.

 WARNING
THE TROUBLESHOOTING GUIDES DO NOT INCORPORATE ROUTINE SAFETY PRECAUTIONS OR PRELIMINARY PROCEDURES. DURING THE RICON WARRANTY PERIOD ONLY A TRAINED, AUTHORIZED RICON SERVICE TECHNICIAN CAN PERFORM TROUBLESHOOTING. AFTER THE WARRANTY PERIOD, IT IS RECOMMENDED THAT TROUBLESHOOTING CONTINUE TO BE PERFORMED BY AN AUTHORIZED RICON SERVICE TECHNICIAN.

1. LIFT TROUBLESHOOTING

TABLE 3-2: LIFT OPERATIONAL TROUBLESHOOTING GUIDE			
SYMPTOM		POSSIBLE CAUSE	REMEDY
Hydraulic fluid leaks		Loose hydraulic fitting.	Make sure fitting is PROPERLY tightened.
		Hydraulic component defective.	Do not use lift until repairs are made by an authorized Ricon service technician.
Rollstop does not open		Obstruction of rollstop release latch.	Raise lift and remove obstruction.
Lift functions	Abnormal operation.	Obstruction in lifting frame.	Remove obstruction and check for any damage
		Backup pump manual release valve OPEN.	Turn manual release valve CLOCKWISE until lightly-snug.
		Hydraulic fluid may be low.	While platform is at GROUND LEVEL, be certain that pump hydraulic fluid level is maintained at required FULL level. Add only Texaco 01554 Aircraft Hydraulic Oil or equivalent U.S. mil spec H5606G fluid.
		Air may be trapped in hydraulic system.	Purge hydraulic system by operating lift through its maximum range of travel for at least four complete cycles. (For vehicles that do not use full travel of lift, the maximum range of travel is accomplished by raising vehicle on a service hoist or ramp.)
	No operation.	Control System Circuit Breaker tripped.	Reset circuit breaker.
		Backup pump manual release valve OPEN.	Turn manual release valve CLOCKWISE until lightly-snug.
		Hydraulic hose or fitting leak.	Contact an authorized Ricon service technician for repair.
		Hydraulic fluid may be low.	While platform is at GROUND LEVEL, be certain that pump hydraulic fluid level is maintained at required FULL level. Add only Texaco 01554 Aircraft Hydraulic Oil or equivalent U.S. mil spec H5606G fluid.
		Air may be trapped in hydraulic system.	Purge hydraulic system by operating lift through its maximum range of travel for at least four complete cycles. (For some vehicles, the maximum range of travel is accomplished by raising vehicle on a service hoist or ramp.)
END OF TABLE			

2. PUMP SOLENOID LED STATUS INDICATOR

Refer to **Figure 3-2**. Two solenoids provide a margin of safety if one of the solenoids fails with its contacts closed. A status two-color indicator LED is located between the 8A and 30A circuit breakers to monitor the condition of the two solenoids. The LED is normally off when the pump is not operating and becomes green when the pump operates. When the pump is not operating and the top solenoid has failed the LED will be red. The LED will be green when the side solenoid has failed.

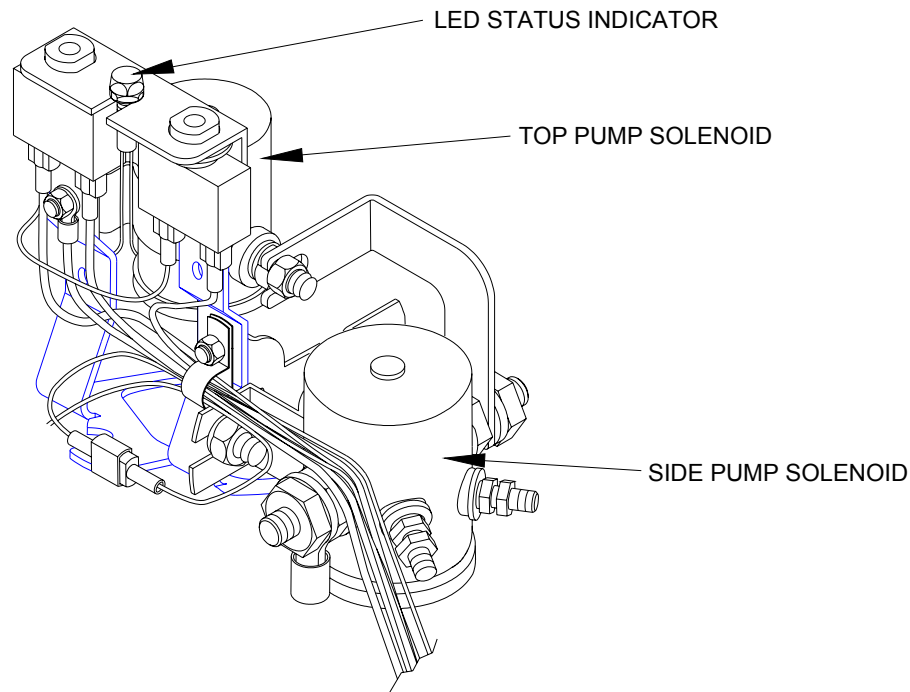

FIGURE 3-2: STATUS INDICATOR FOR PUMP SOLENOIDS

3. BRIDGEPLATE CABLE ASSEMBLY REPLACEMENT

The following steps provide instructions for replacing the bridgeplate (also known as inner rollstop or IRS) cable assembly. Refer to **Figure 3-3** on following page. Please follow these instructions carefully. Call Ricon Product Support if you need assistance.

- a. Study the routing of the cable before removing it.
- b. Deploy the lift platform to vehicle floor level. Be certain that bridgeplate is resting against baseplate assembly.
- c. Remove pinch point shields from the left and right vertical arm assemblies.
- d. Assemble and secure one end of an IRS cable to the IRS pulley mount block (#1; located inside the left vertical arm assembly) using a hex screw, bushing, and washer.
- e. Route the cable around the IRS pulley mount block bushing (#2). Verify that cable is routed between the bushing tab and the point where the cable makes contact with the bushing. Install washer and hex nut over bushing and cable assembly.
- f. Continue to route the cable around grooved bearings #3, #4, and #5.
- g. Route the cable down the length of the vertical arm assembly and around grooved bearing #6.
- h. Assemble and secure the end of the IRS cable to the left side of the bridgeplate (#7) using a hex screw, washer, bushing, and he nut. Be sure to install a hex nut on the inside of the inner rollstop.
- i. Repeat for right side.
- j. Reinstall pinch point shields removed in step 2.

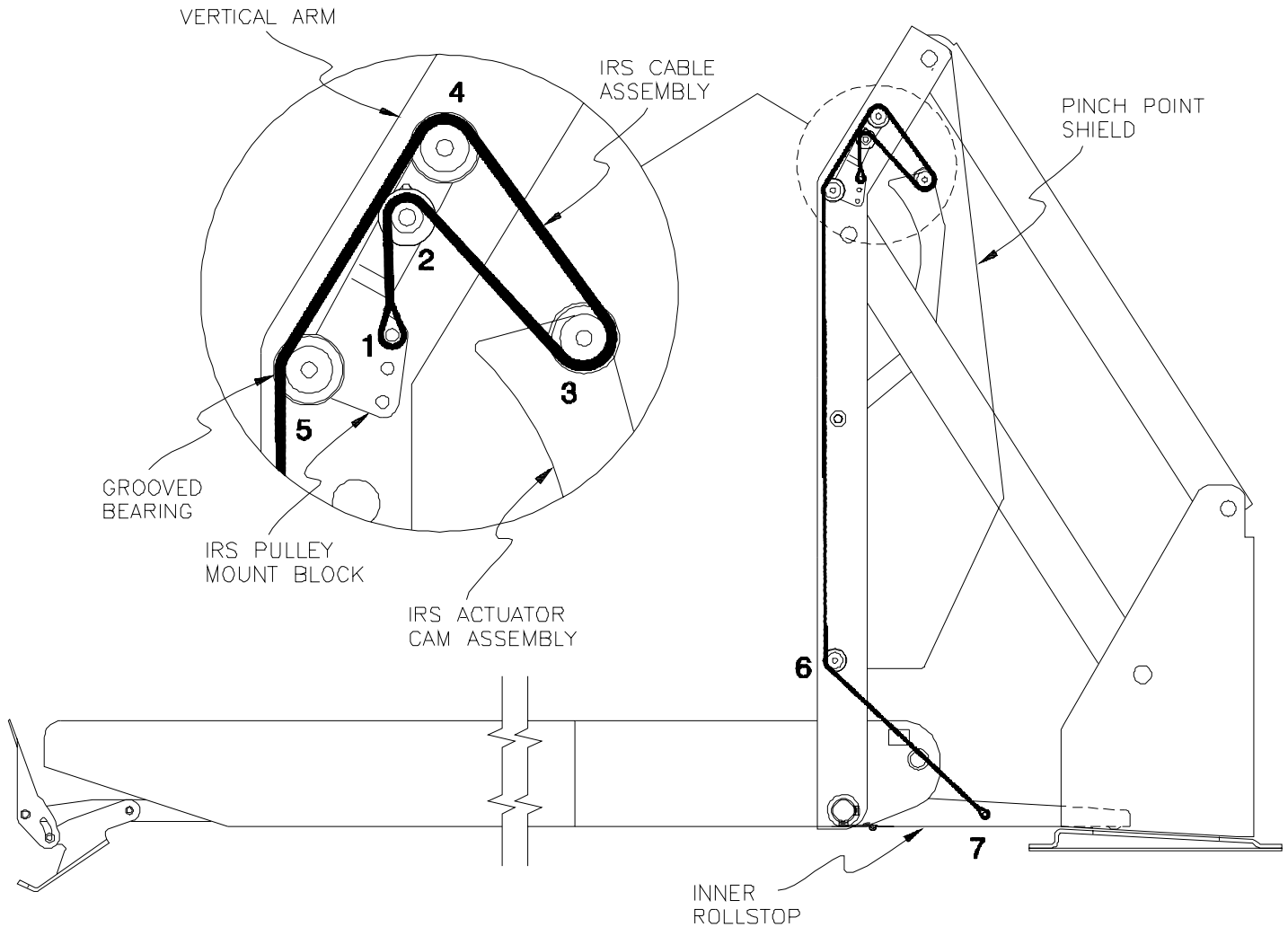
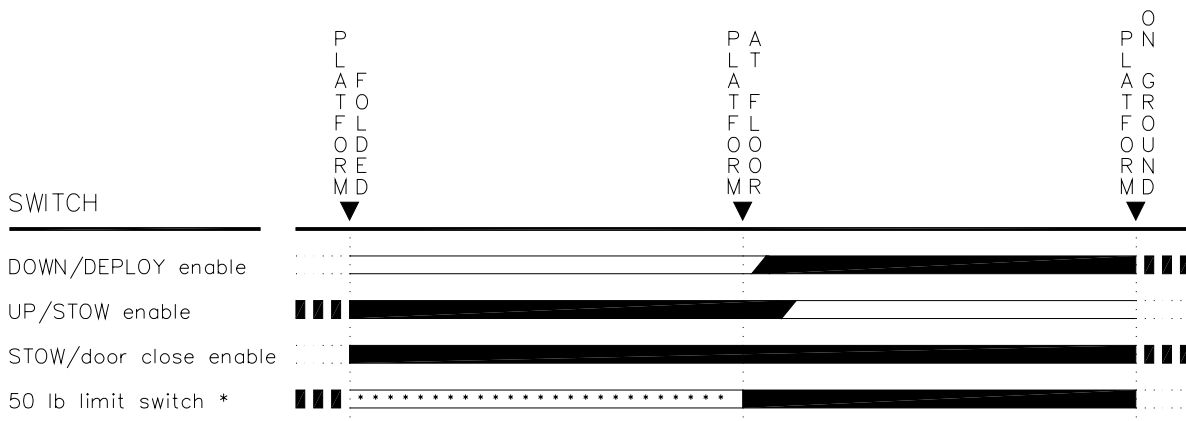

FIGURE 3-3: BRIDGEPLATE CABLE ROUTING

4. LIMIT SWITCH STATES

Refer to **Figure 3-4**. The limit switch actuation chart shows the state of all limit switches as the platform travels from stowed, to vehicle floor level, and then to ground level. The solid line segments (—) represent current flow through the normally CLOSED switch contacts, and the open line segments (≡) represent current flow through the normally OPEN switch contacts. The heavy dashed lines (■■■) show switch states when platform is beyond normal travel boundaries. This is useful in showing the operation of switches that change states at stowed or ground level positions. For proper operation of lift, the switch actuations must overlap as shown.



* 50 lb limit switch actuates when weight on platform exceeds 50 lbs during IN platform motion.

FIGURE 3-4: LIMIT SWITCH ACTUATION CHART

E. HYDRAULIC CIRCUIT DIAGRAM

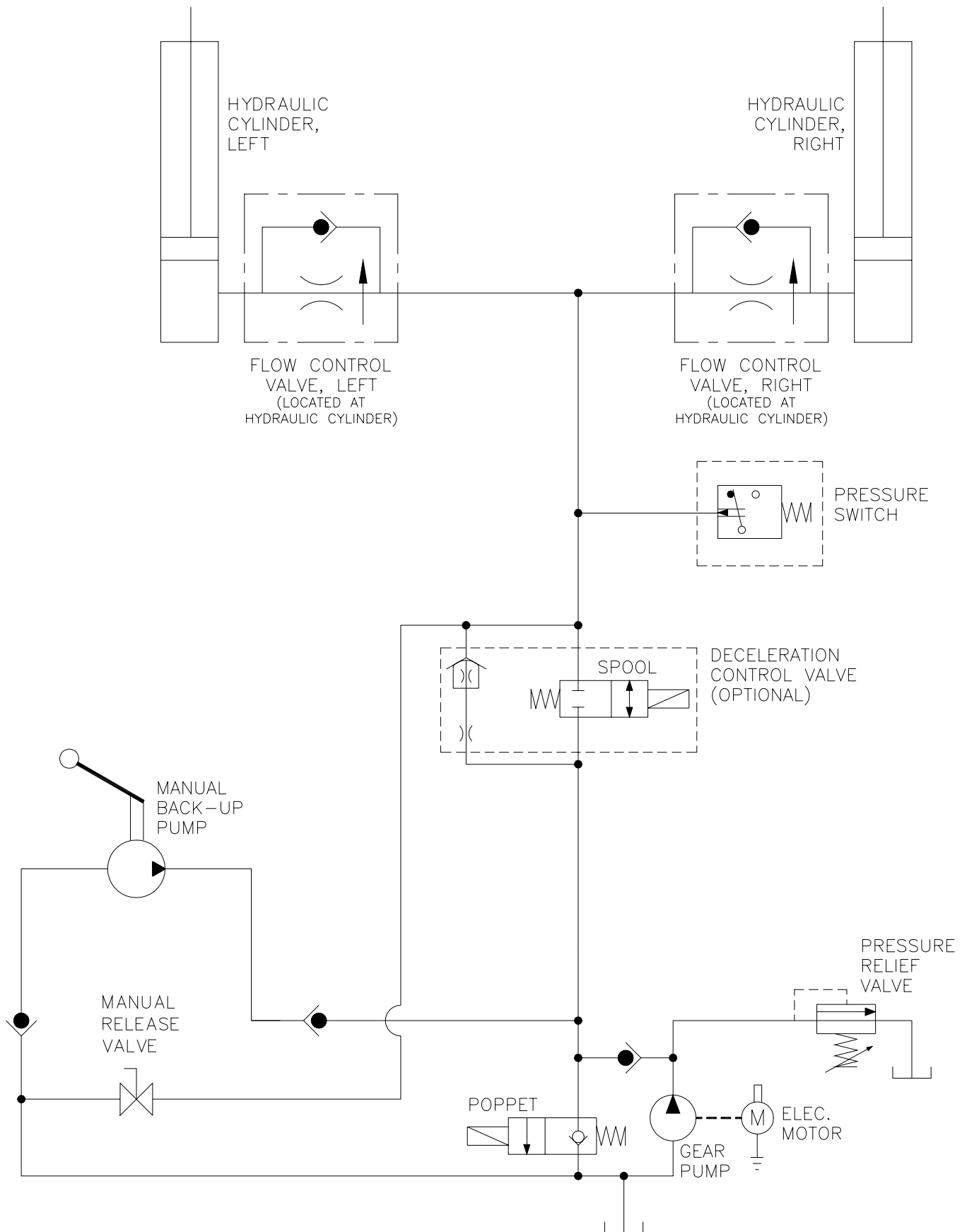

FIGURE 3-5: K-SERIES HYDRAULIC CIRCUIT DIAGRAM

F. ELECTRICAL WIRING DIAGRAMS

1. DIAGRAM LEGENDS

a. Wire Color Codes

TABLE 3-3: WIRE COLOR CODES			
LETTER	COLOR	LETTER	COLOR
BK	Black	R	Red
BL	Blue	VI	Violet
BR	Brown	GY	Gray
GN	Green	W	White
O	Orange	Y	Yellow

END OF TABLE

b. Electrical Connector Description

Refer to **Figure 3-6**. The standard electrical connectors, used by Ricon are Molex .062" Series. These connectors have terminal numbers molded onto the back; use these numbers and colors to identify wires.

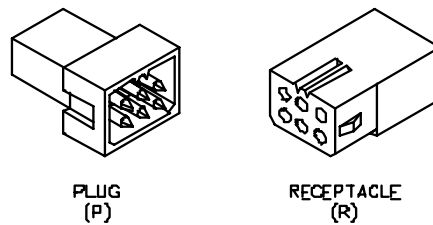

FIGURE 3-6: MOLEX CONNECTORS

c. Diagram Labels

12V	12 Volts – Circuit current rating is also given
DC	Door Close – Direct command
DO	Door Open – Direct command
DOE	Door open Enable – From Door Open cutoff switch
DWN	Pump Down – Used by OUT and DWN
DWNA	Down Attempt – Must be enabled
FAST	Signal to speedup valve for UP and DOWN
GND	GROUND
OUTA	Out Attempt – Out must be enabled
SDA	System Deploy Attempt – DO followed by OUT
SSA	System Stow Attempt – IN followed by DC
UP	Pump Up – Used by UP and IN
UPA	Up Attempt – Up must be enabled

FIGURE 3-7: DIAGRAM LABELS

d. Electrical Symbols

Figure 3-8 defines the symbols used on the electrical wiring diagrams.

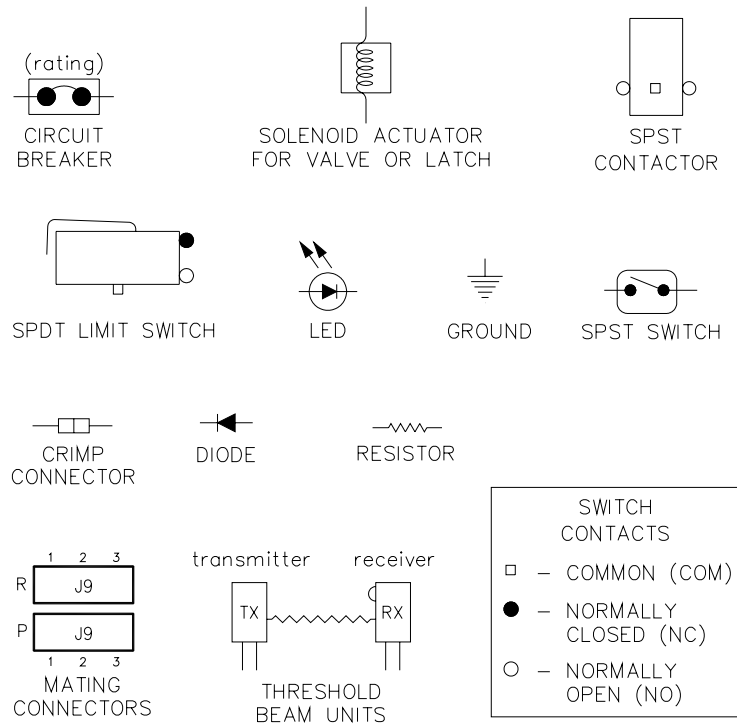

FIGURE 3-8: ELECTRICAL WIRING DIAGRAM SYMBOLS

2. WIRING DIAGRAMS

Refer to **Figures 3-9** and **3-10** on the following two pages.

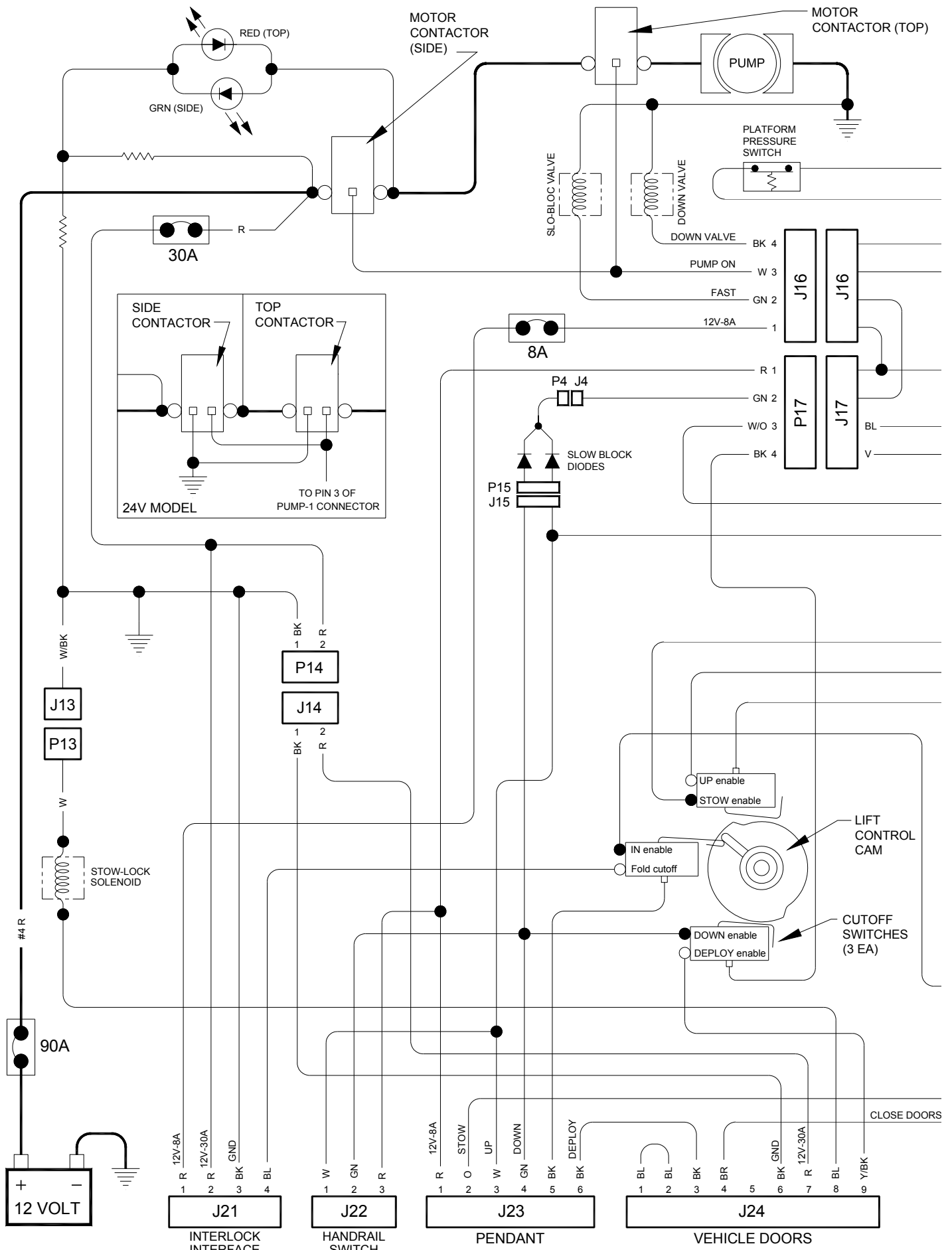
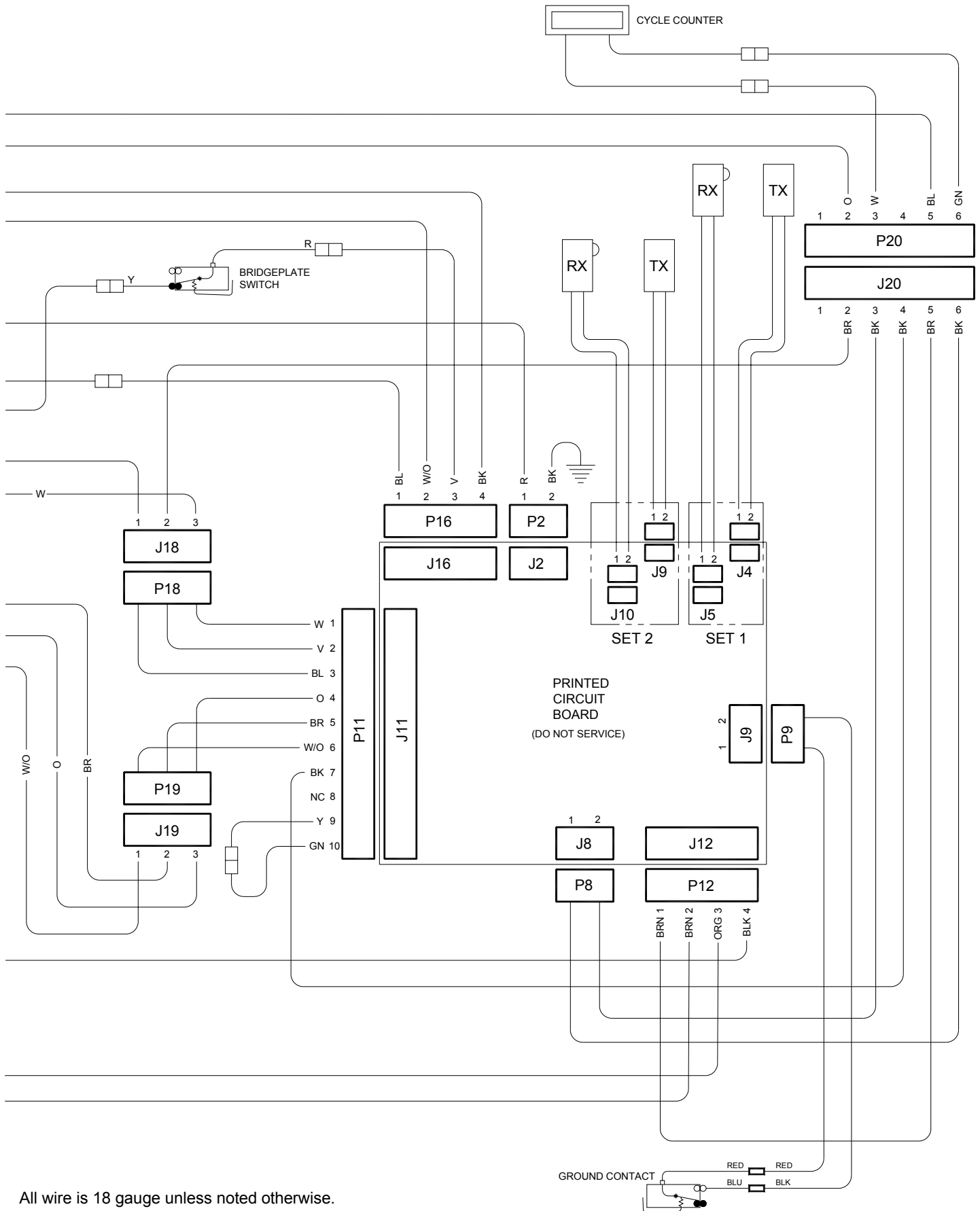

FIGURE 3-9: K-SERIES DOT PRIVATE USE LIFT SCHEMATIC – SHEET 1
32DSSK04.A



All wire is 18 gauge unless noted otherwise.

FIGURE 3-10: K-SERIES DOT PRIVATE USE LIFT SCHEMATIC – SHEET 1

This page intentionally left blank.

IV. K-SERIES PRIVATE USE SPARE PARTS

This chapter contains parts diagrams and lists for the RICON K-Series Private Use wheelchair lift. The exploded view of each major lift assembly shows individual components referenced by numbers. On each associated list are reference numbers, part descriptions, quantities used, and RICON part numbers.

NOTE: To order a part, locate the part or assembly on an exploded view, note its reference number, find this number on the associated parts list (following page), and order the part number in the far right column. Most kits contain a single part (plus hardware). Therefore, you may need to order more than one kit if the part is used more than once on a major assembly. Small hardware and fasteners are supplied in bags of ten. The quantity listed is the number of bags needed for the assembly in the figure. In most cases the bag will contain more pieces than needed.

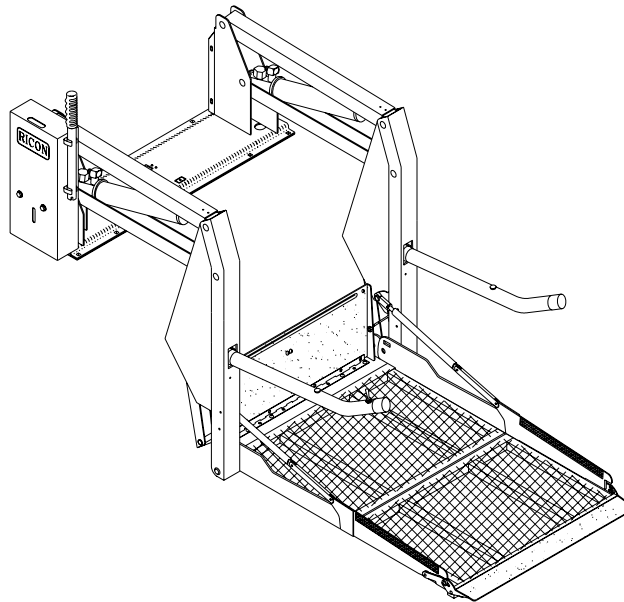

PARTS DIAGRAM		PAGE
FIGURE 4-1	PRIVATE USE DECALS.....	4-2
FIGURE 4-2	PRIVATE USE PUMP ASSEMBLY	4-4
FIGURE 4-3	PRIVATE USE HYDRAULIC SYSTEM	4-6
FIGURE 4-4	PRIVATE USE ELECTRICAL SYSTEM.....	4-8
FIGURE 4-5	PRIVATE USE PENDANT.....	4-10
FIGURE 4-6	PRIVATE USE K1132 PLATFORM.....	4-12
FIGURE 4-7	PRIVATE USE K1200 PLATFORM.....	4-14
FIGURE 4-8	PRIVATE USE K1203 PLATFORM.....	4-16
FIGURE 4-9	PRIVATE USE K1205 PLATFORM.....	4-18
FIGURE 4-10	PRIVATE USE TRAVELING FRAME	4-20
FIGURE 4-11	PRIVATE USE HANDRAILS	4-23
LIFT SPECIFICATIONS		4-24

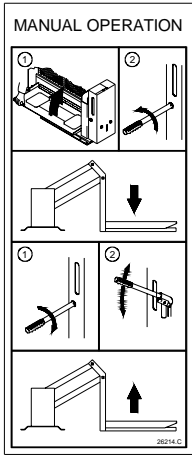

MANUAL OPERATION
PN 26214

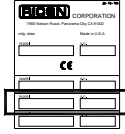

PART OF SERIAL NUMBER
DECAL (LOCATED ON
INNER SIDE OF HYDRAULIC
CYLINDER; ONLY RICON
REPLACEABLE)



PART OF SERIAL NUMBER
DECAL (ONLY RICON
REPLACEABLE)

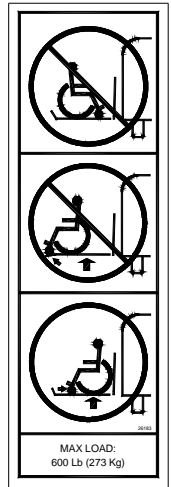

MAXIMUM
LOAD
PN 26183

MAX LOAD:
600 Lb (273 Kg)

PUMP COVER
PN 26292



K-SERIES
PATENT NO.
PN 19518



DOT - Private Use Lift

DOT-PRIVATE
USE LIFT
PN 32141



RICON LOGO
(BOTH SIDES)
PN 32-10-152

K-SERIES PRIVATE USE WHEELCHAIR LIFT

WARNING:
Improper use of lift can result in personal injury. User must read and follow operating instructions in Operator Manual. Additional copies of Operator Manual are available from:
RICON CORPORATION
7300 NELSON ROAD
PANORAMA CITY, CA 91402
(800) 322-3864
(818) 267-3000

2) Do not exceed rated load.
3) Inspect wheelchair lift for damage, correct lift functions, and required maintenance prior to use. Do not use lift if a problem exists, and send to an authorized service technician for repair.
4) This lift is designed for use by wheelchair occupants only. **DO NOT USE FOR STANDING PASSENGERS.**

Ricon Corporation disclaims liability for damage or personal injury resulting from lift modification, lack of maintenance, faulty repair, negligence, abuse, or failure to follow lift operating instructions.

OPERATING INSTRUCTIONS:
(Also read Operator Manual)

Deploy Lift:
1) Open doors fully. Power doors open automatically when DEPLOY button is actuated. Lift will unfold and stop at vehicle floor level.
2) Use pendant switch to apply power to pendant.
3) Press and hold DEPLOY button to unfold platform and lower it to vehicle floor level.
4) Press and hold DOWN button to lower platform to ground level.

Enter Vehicle:
1) Proceed to center of platform, and face outward, if possible. **LOCK WHEELCHAIR BRAKES.**
2) Press and hold UP button to raise platform to vehicle floor level.
3) Release wheelchair brakes and enter vehicle.

Exit Vehicle:
1) Proceed to center of platform, and face outward, if possible. **LOCK WHEELCHAIR BRAKES.**
2) Press and hold DOWN button to lower platform to ground level.
3) Release wheelchair brakes and exit platform.

Stow Lift:
1) Press and hold STOW button to fold platform and return it to stowed position.
2) Turn pendant switch off.
3) Close doors.

MANUAL OPERATION:
See Manual Operation instructions in Operator Manual or pump cover.

CAUTION:
Safety park vehicle before using lift. Keep wheel of lift when it is in motion. Position wheelchair in center of platform to prevent interference with cover retraction when it rises.

32143.A

PRIVATE USE
OPERATING
INSTRUCTIONS
PN 32143

DECAL REFLECTIVE,
RED AND WHITE
(BOTH SIDES)
PN 33011



FIGURE 4-1: PRIVATE USE DECALS

This page intentionally left blank.

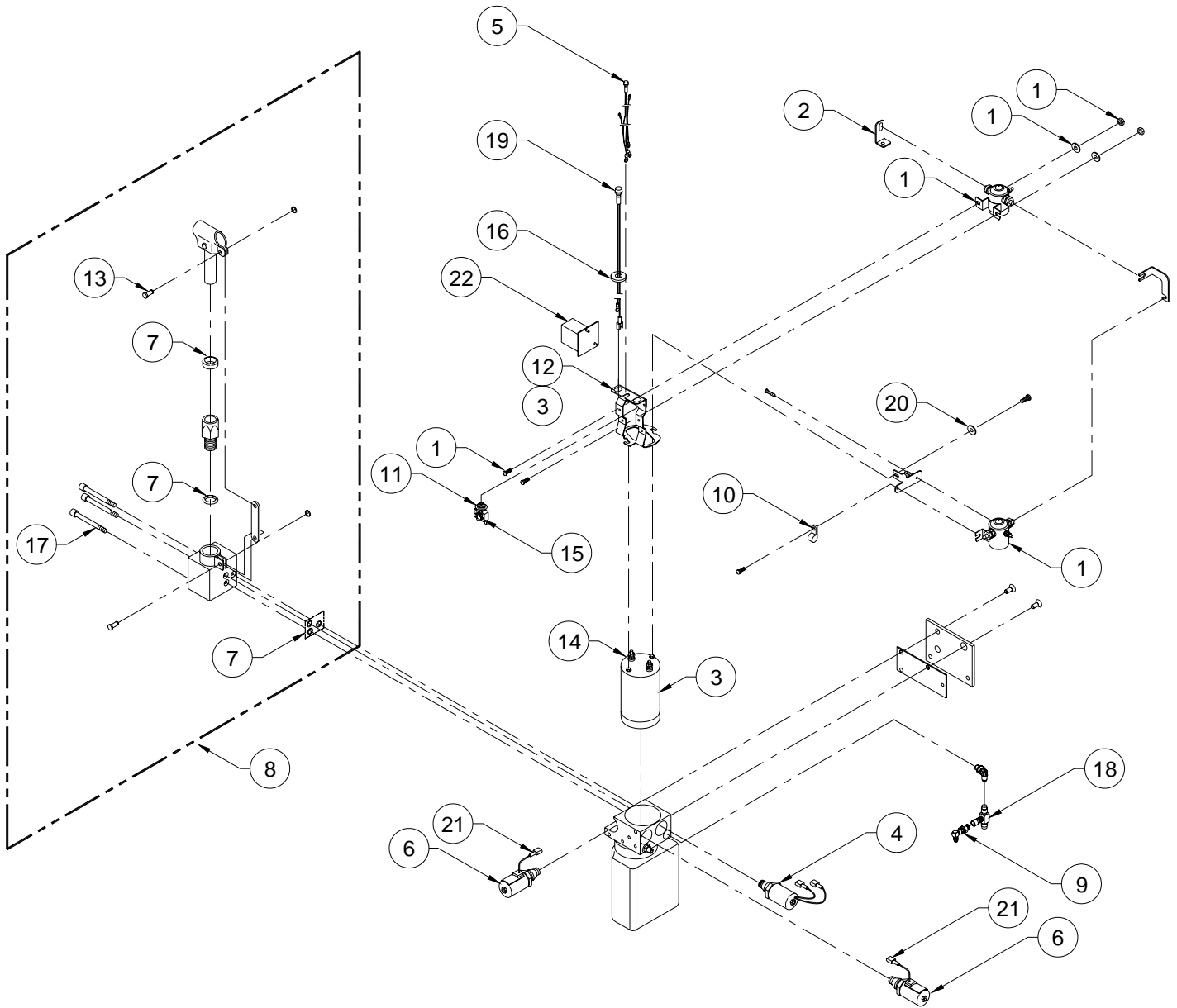

FIGURE 4-2: PRIVATE USE PUMP ASSY

FIGURE 4-2: PRIVATE USE PUMP ASSEMBLY

REF	DESCRIPTION	QTY	PART NO
1	KIT, SOLENOID, 12V, SPST	2	29297
2	BUS BAR, ISKRA MOTOR	1	10807
3	KIT, MOTOR ASSY, W/BRACKET, 12V	1	14345
4	SWITCH, HYDRAULIC PRESSURE, ADJUSTABLE	1	15207
5	INDICATOR LIGHT ASSY, 12V	1	19067
6	SPOOL VALVE ASSY, 12V	1	01176
7	KIT, SEAL, MANUAL BACK-UP PUMP	1	V2-SH-220
8	BACK-UP PUMP, MANUAL	1	V2-SH-210
9	FITTING ASSY, SNL, 1/4J X 1/4J, STEEL	1	VS-SH-06
10	CABLE CLAMP, 3/16", NYLON, BAG OF 10	1	19798
11	CIRCUIT BREAKER KIT, 8 AMP, w/HDWR & DECAL	2	V2-SH-005
12	BRACKET, SOLENOID	1	10507
13	PIN & RETAINING RING	2	V2-SH-017
14	KIT, PUMP MOTOR BRUSH SET (located inside motor)	1	14334
15	DECAL, 8 AMP CIRCUIT BREAKER	1	18797
16	ADAPTER, .625 D-HOLE TO .484 ROUND	1	V2-ES-059
17	SCREW, SHC, 1/4-20 X 2.25L, BAG OF 10	3	32407
18	FITTING, SRT, 1/4J, STEEL	1	V2-SH-012
19	LIGHT, LIFT ARMED INDICATOR, 12V, GREEN	1	UL-ES-034
	LIGHT ASSY, INDICATOR, 12V, RED OR GREEN	1	19067
20	WASHER, FLAT, .406X.812X.065, BAG OF 10	1	17510
21	TERM, SLIP, M22-18 FULL INSUL, BAG OF 10	1	33336
22	COUNTER ASSY	1	33048

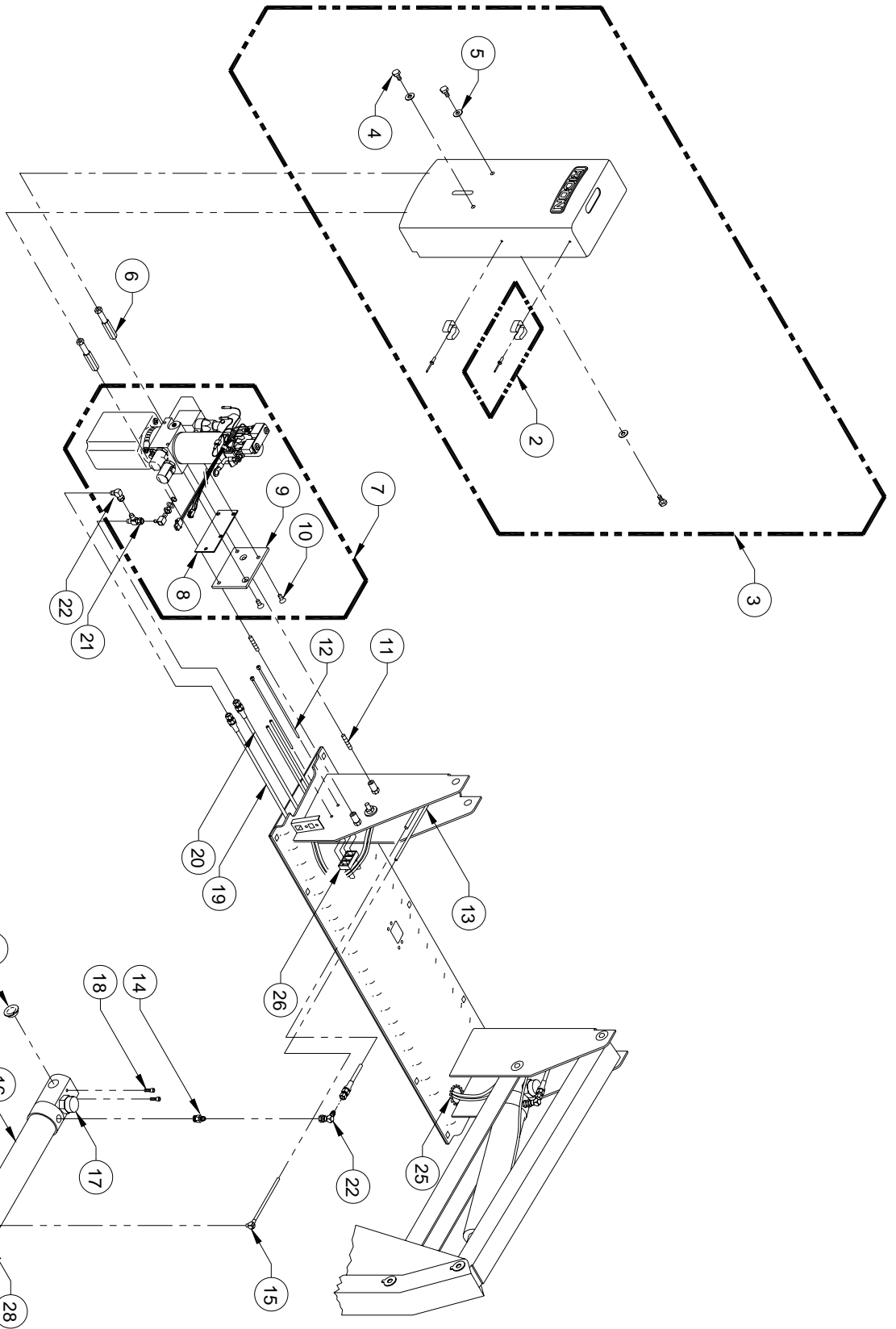
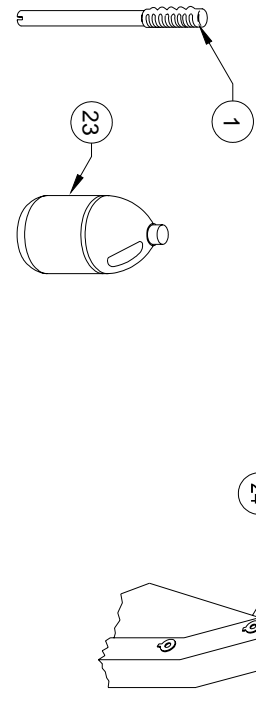
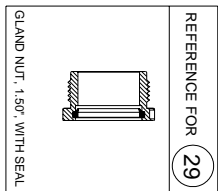
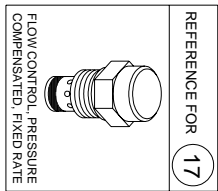
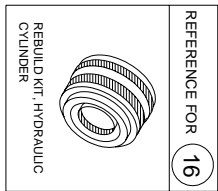
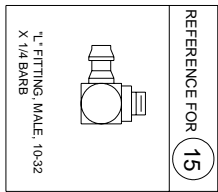

FIGURE 4-3: PRIVATE USE HYDRAULIC SYSTEM

FIGURE 4-3: PRIVATE USE HYDRAULIC SYSTEM

REF	DESCRIPTION	QTY	PART NO
1	HANDLE, MANUAL BACKUP PUMP	1	V2-SH-111
2	KIT, TOOL CLIP, W/HDWR	2	19557
3	COVER, ASSY, PUMP, LH	1	V2-CV-220
4	SCREW, HEX, 5/16-18 X .625, BAG OF 10	3	14495
5	WASHER, FLAT, 5/16", BAG OF 10	3	13350
6	HEX ROD, PUMP STANDOFF	2	V2-CV-015
7 *	PUMP ASSY, 12V, FMVSS, LH MOUNTING, COUNTER, PRESSURE SWITCH, W/INTERLOCK	1	PM212210100
8	PLATE, PUMP COVER MOUNT	1	V2-AC-71
9	PLATE, PUMP MOUNT	1	V2-AC-70
10	SCREW, FLAT HEAD, 5/16-18 X 3/4", BAG OF 10	2	14499
11	STUD, THREADED, 5/16-18 X 1.75", BAG OF 10	2	14500
12	CABLE TIE, 5.5", BLACK, BAG OF 10	2	25697
13	TUBE, POLYURETHANE, 6MM x 4MM, BLACK	9'	22-02-230
14	ADAPTOR, # 6 SAE MALE X # 4 JIC MALE	2	26591
15	FITTING, "L", MALE 10-32 X 1/4, BARB	2	V2-SH-16
16	KIT, CYLINDER REPAIR, W-PISTON ASSY, GLAND NUT, AND SEAL	2	V2-SH-56
17	KIT, FLOW CONTROL, FIXED RATE .50 GPM, KIT OF 2	1	30968
18	SCREW, HEX RECESS HEAD, 1/4-20 X 1, BAG OF 10	4	14491
19	HYDRAULIC HOSE, 52.5" X 1/4 JIC X 1/4 JIC, K1100	1	11732
	HOSE ASSY, HYDRAULIC, 61" X 1/4 JIC X 1/4 JIC, K1200	1	V2-SH-009
20	HYDRAULIC HOSE, 21.5" X 1/4 JIC X 1/4 JIC, K1100	1	11731
	HOSE ASSY, HYDRAULIC, 26" X 1/4 JIC X 1/4 JIC, K1200	1	V2-SH-008
21	FITTING, RUN TEE, 1/4 JIC, M-M-F	1	V2-SH-012
22	FITTING, "L", 1/4 JIC M-F SWIVEL	3	VS-SH-06
23	OIL, HYDRAULIC, TEXACO #15, MEETS MIL-H-5606G	1 GAL	20-16-051
24	CYLINDER ASSY, S1100 SERIES & S1200 SERIES	2	VS-SH-105
25	GROMMET, CATERPILLAR, 3/16" X 12"	1	26647
26	SPACER, CABLE OR HOSE	2	25557
27	BUSHING, 3/4"ID X 3/8W	4	25386
28	GLAND NUT, 1.50", WITH SEAL	2	13009

* Refer to Pump Assembly figure for parts breakdown.

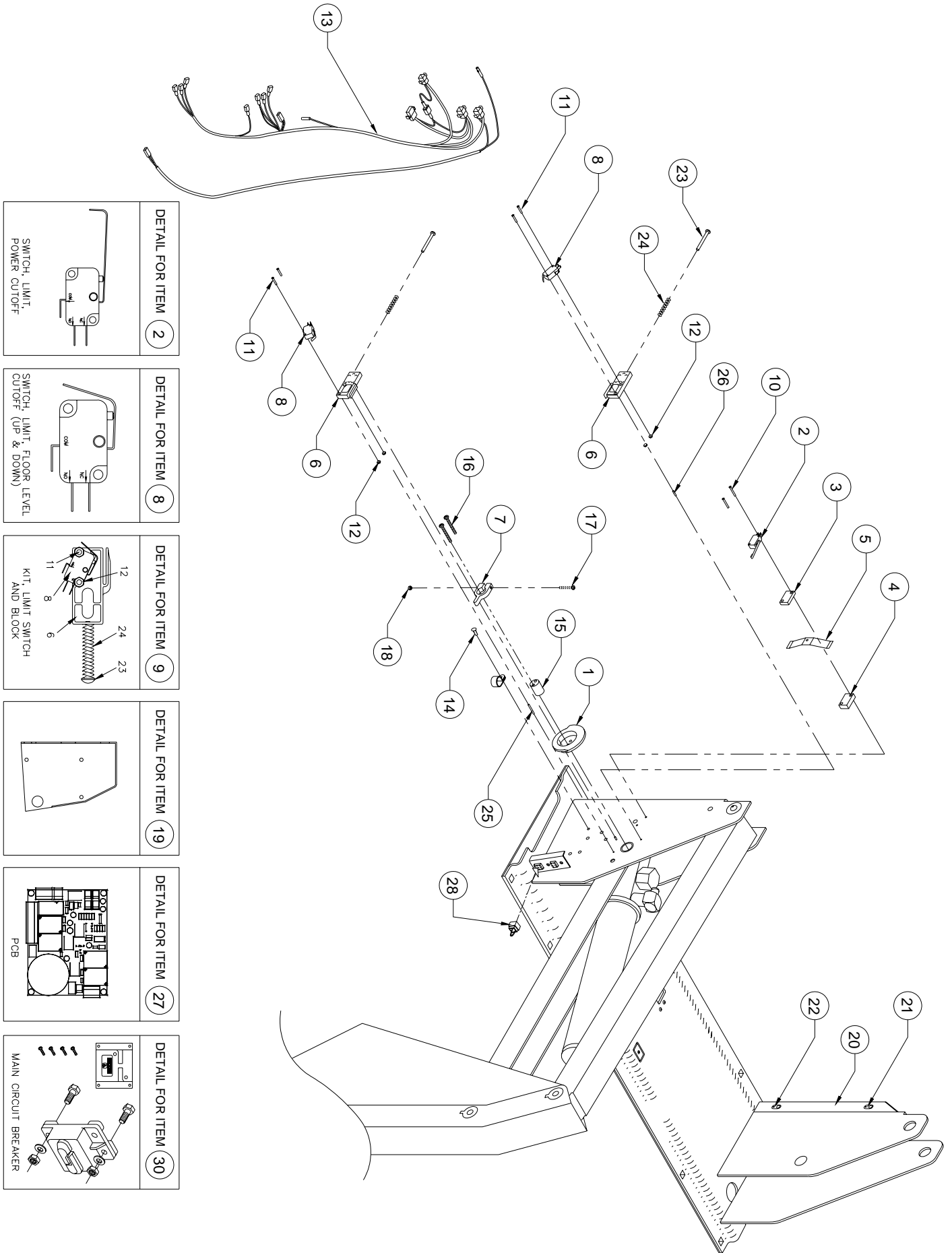

FIGURE 4-4: PRIVATE USE ELECTRICAL DIAGRAM

32DSSK04.A

FIGURE 4-4: PRIVATE USE ELECTRICAL SYSTEM

REF	DESCRIPTION	QTY	PART NO
1	CAM, LIFT CONTROL	1	V2-AC-107
2	SWITCH, LIMIT, FOLD CUTOFF	1	V2-ES-111
3	BLOCK, FOLD CUTOFF SWITCH OFFSET, 1/4" THICK	1	V2-ES-78
4	BLOCK, FOLD CUTOFF SWITCH OFFSET, 3/8" THICK	1	V2-ES-79
5	SPRING, RETAINING, UPPER/LOWER SWITCH BLOCK	1	V2-ES-95
6	SWITCHBLOCK	2	34314
7	ACTUATOR, FOLD CUTOFF	1	V2-AC-089
8	SWITCH, LIMIT, FLOOR LEVEL POWER CUTOFF, UP & DOWN	2	V2-ES-110
9	KIT, LIMIT SWITCH BLOCK REPLACEMENT	2	V2-ES-61
10	SCREW, 4-40 X 1.25 PAN HEAD, BAG OF 10	1	15908
11	SCREW, 4-40 X .75 PAN HEAD, BAG OF 10	1	15909
12	NUT, HEX, 4-40, BAG OF 10	1	14407
13	ELECTRICAL HARNESS, MAIN, w/INTERLOCK, S1100 SERIES	1	34201
	ELECTRICAL HARNESS, MAIN, w/INTERLOCK, S1200 SERIES	1	33073
14	MS, 10-24 X 1/2 PHIL PAN, BAG OF 10	1	13304
15	PIN, EXTENSION FOLD CUTOFF, BAG OF 10	1	15914
16	MS 10-24 X 1 3/4 PHIL PAN, BAG OF 10	1	29318
17	MS 8-32 X 1 1/4 PHIL PAN, BAG OF 10	1	15906
18	NUT-HEX 8-32 NYLON INSERT, BAG OF 10	1	15907
19 *	COVER ASSY, PUMP, L/H	1	V2-CV-220
20	ENCLOSURE, PHOTOBEAM SENSORS	1	31779
21	SENSOR, PHOTOBEAM, RECEIVER	2	32499
22	SENSOR, PHOTOBEAM, TRANSMITTER	2	32498
23	SCREW, RD HEAD, 10-24 X 2", BAG OF 10	1	14497
24	SPRING, COMPRESSION, .30 OD X 2.06L	2	V2-ES-93
25	ROLLPIN, .094 X 1.0, BAG OF 10	1	14498
26	ROLLPIN, .094 X .50, BAG OF 10	1	14496
27	PCB ASSEMBLY, PRIVATE	1	33057
28	SHORTING PLUG	1	UL-ES-007
29 **	HARNESS, PCB TO CAM SWITCH	1	34203
30	KIT, CIRCUIT BREAKER, MAIN (90A)	1	01010K

* Used for left hand installation only.

** Not shown.

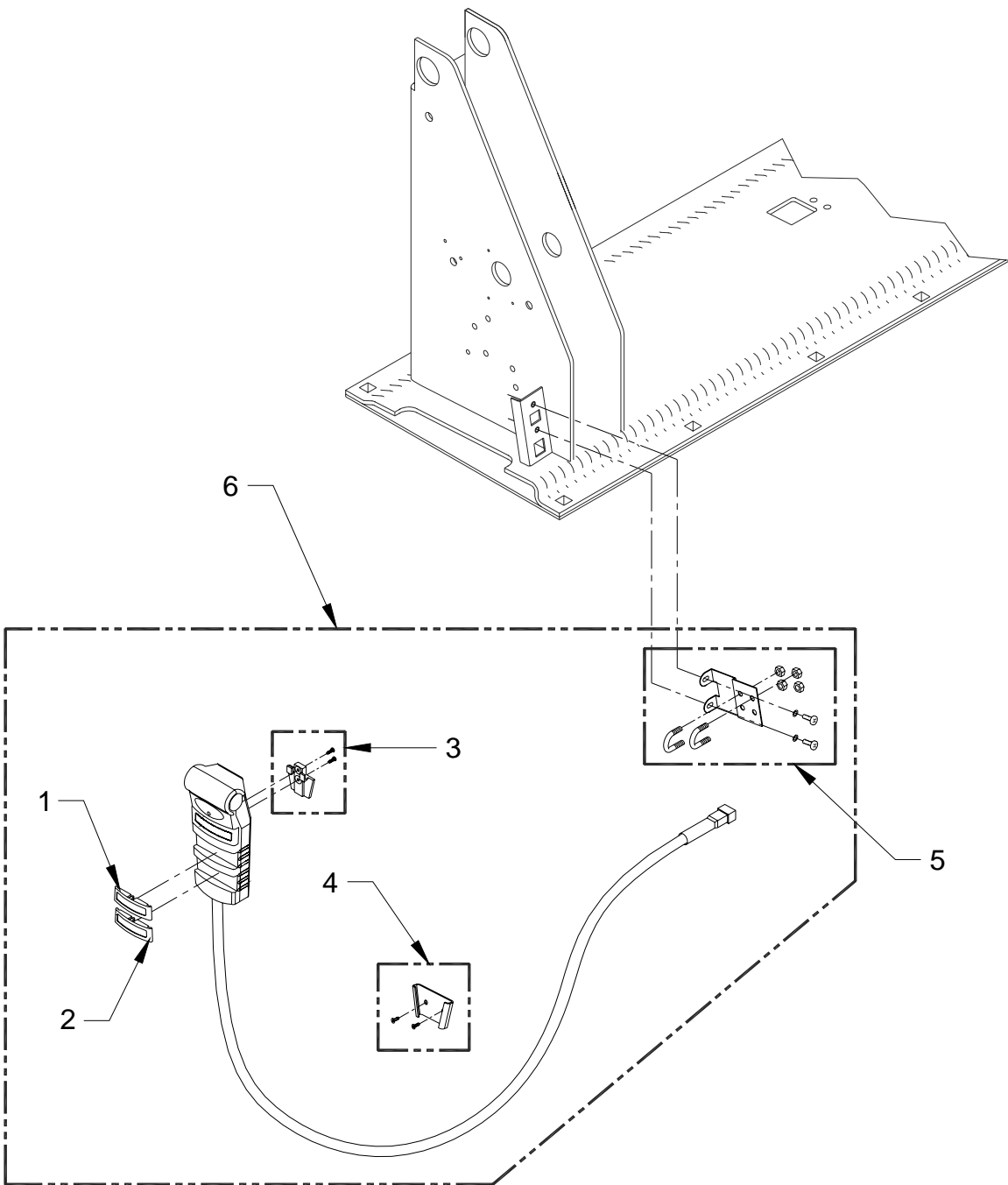

FIGURE 4-5: PRIVATE USE PENDANT

32DSSK04.A

FIGURE 4-5: PRIVATE USE PENDANT

REF	DESCRIPTION	QTY	PART NO
1	STOW/DEPLOY BUTTON	1	14731
2	UP/DOWN BUTTON	1	14732
3	V-BRACKET, PLASTIC, W/HDWR	1	14733
4	KIT, WALL MOUNT BRACKET, UNIVERSAL PENDANT	1	14709
5	KIT, CONTROL HARNESS STRAIN RELIEF	1	01007
6	KIT, PENDANT, 7 FT	1	14727
	KIT, PENDANT, COILED CORD	1	14728
	KIT, PENDANT, 10 FT	1	14729
	KIT, PENDANT, STEEL JACKETED CORD	1	14730

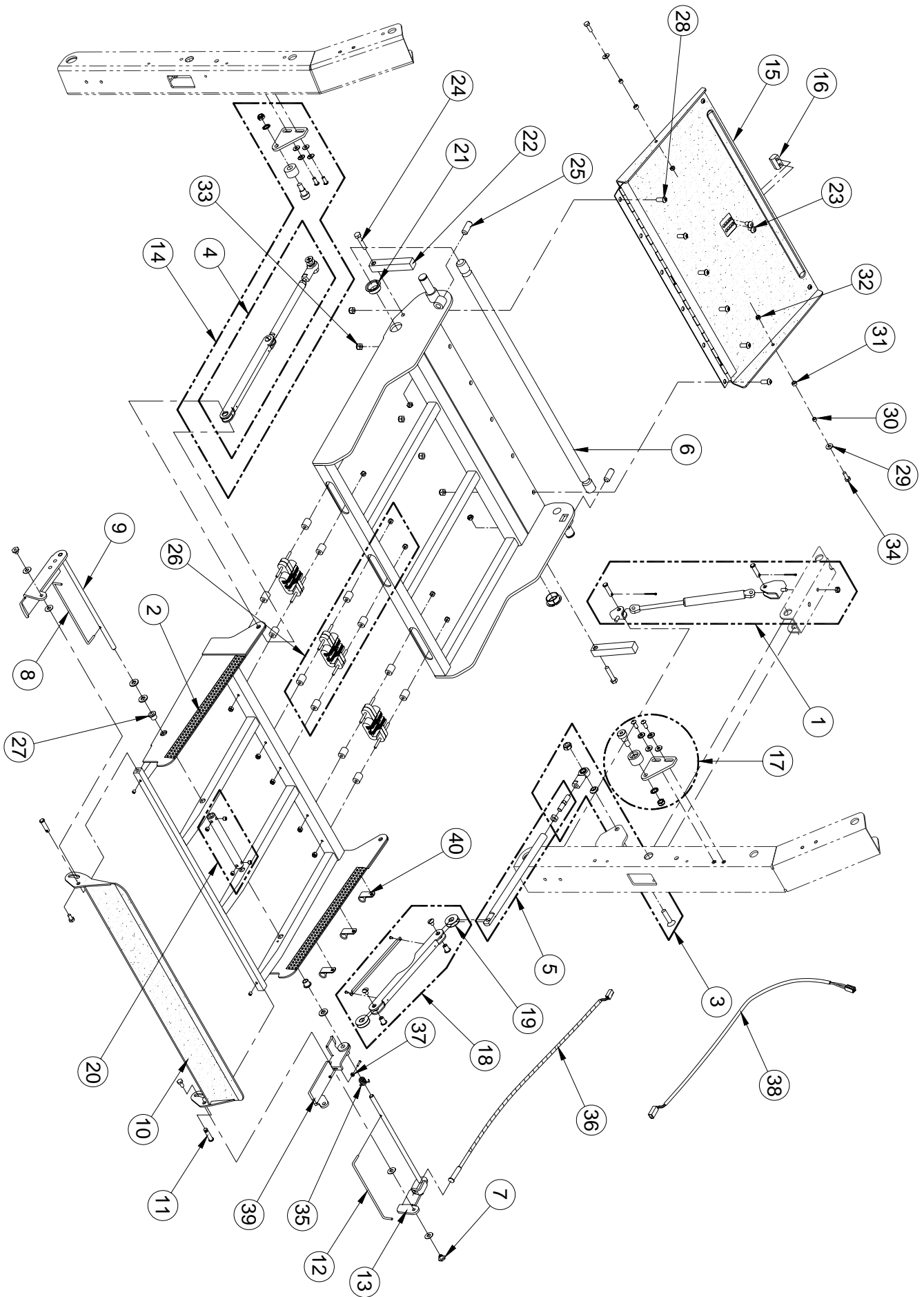

FIGURE 4-6: PRIVATE USE FOLDING PLATFORM ASSEMBLY, K1132

FIGURE 4-6: PRIVATE USE FOLDING PLATFORM ASSEMBLY, K1132

REF	DESCRIPTION	QTY	PART NO.
1	KIT, PNEUMATIC SPRING, W-BRACKETS & HDWR	2	21647
2	DECAL, REFLECTIVE, 3.0 X 18, RED & WHITE	2	33011
3	ROD END ASSY, W/HDWR	1	29224
4	LINK ASSY	2	21645
5	KIT, LINK, REAR, 6.75", W/HDWR (left & right side included in kit)	1	29244
6	SHAFT, MAIN, 1" X 32.50	1	VS-PI-14
7	T-NUT, ¼-20X1/4, SST, BAG OF 10	1	14485
8	TORSION BAR, LH	1	V3-SP-21
9	ROLLSTOP ACTUATOR, LH, W/SKI	1	32960
10	ROLLSTOP	1	32912
11	PIN, CLEVIS, 5/16X1-1¼, BAG OF 10	1	19513
12	TORSION BAR, RH	1	V3-SP-22
13	ROLLSTOP ACTUATOR, RH	1	32959
14	KIT, LINK ASSY & BRACKETS, SHORTARM (left & right side included in kit)	1	32824
15	BRIDGEPLATE ASSY, INBOARD	1	33074
16	CATCH, BASE LATCH	1	V2-AC-103
17	KIT, BRACKETS, W/CAM FOLLOWER (left & right side included in kit)	1	31247
18	LINK ASSY, FRONT PLATFORM	2	29222
19	WASHER, DELRIN, 1" OD X .38 ID X .03, BAG OF 10	1	25628
20	KIT, COLLAR, ROLLSTOP ACTUATOR, 6.25", W/HDWR	1	28775
21	KIT, FLANGED BEARING, 1" ID, KIT OF 10	1	19579
22	BLOCK, PLATFORM LEVEL ADJUST	2	VT-AH-142
23	SCREW, BUTTON HEAD, 5/16-18X ½, SST, BLK OX, BAG OF 10	1	14484
24	SCREW, HEX HEAD, 5/16-18X 1 ½, GR5, BAG OF 10	1	14403
25	SETSCREW, ½-20X1¼, W/NYLON INSERT, BAG OF 10	1	19704
26	KIT, HINGE, W/HDWR	3	14352
27	BUSHING, .392 ID, BRONZE	2	V2-BU-195
28	SCREW, BUTTON HEAD, 5/16-18X ¾, SST, BLK OX, BAG OF 10	1	15983
29	WASHER, FLAT, .28X.62X.06, BAG OF 10	1	17504
30	BUSHING, STEEL, .25 ID X .32 OD X .19L	2	V2-BU-003
31	SPACER, .25ID X .40 OD X .2L	2	33805
32	NUT, W/NYLON INSERT, ¼-20, BAG OF 10	1	15919
33	NUT, W/NYLON INSERT, 5/16-18, SST, BAG OF 10	1	14415
34	SCREW, HEX HEAD, ¼-20 X ¾, GR5, BAG OF 10	1	34578
35	SPRING, ROLLSTOP, TORSION	1	30589
36	SENSOR ASSY, ROLLSTOP	1	32755
37	MAGNET, SENSOR, ROLLSTOP	1	MM-400
38	HARNESS, ROLLSTOP SENSOR	1	32710
39	SKI, RH	1	32956
40	CLAMP, 3/8 ID, VINYL LINER	3	295-11121

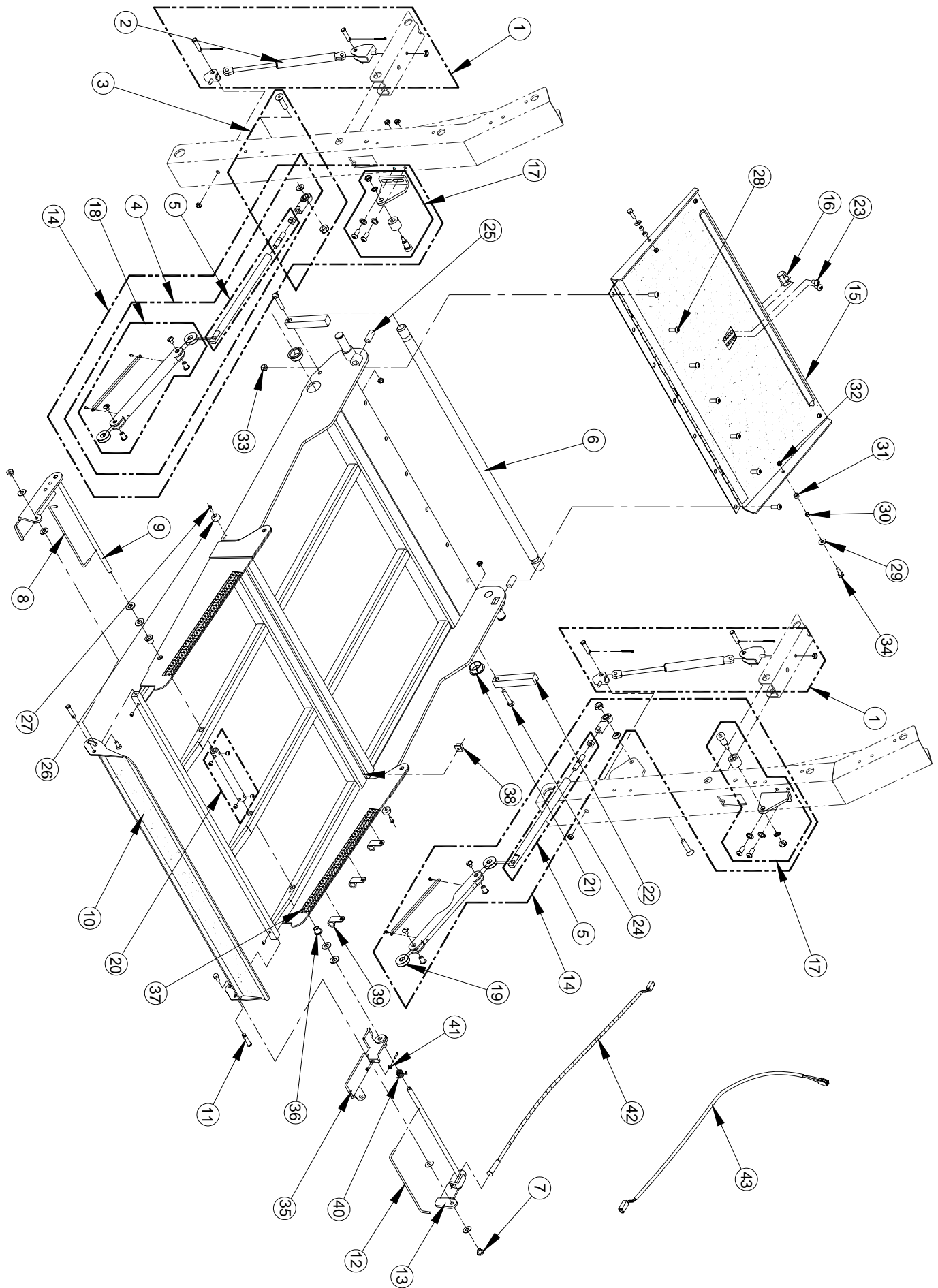

FIGURE 4-7: PRIVATE USE FOLDING PLATFORM ASSEMBLY, K1200

32DSSK04.A

FIGURE 4-7: PRIVATE USE FOLDING PLATFORM ASSEMBLY, K1200

REF	DESCRIPTION	QTY	PART NO.
1	KIT, PNEUMATIC SPRING, RETROFIT (left & right side included in kit)	2	19318
2	SPRING, PNEUMATIC ASSIST	2	R5-SP-502
3	ROD END ASSY, W/HDWR	2	29224
4	KIT, LINK ASSY	2	19507
5	KIT, LINK ASSY, REAR FOLDING PLATFORM (left & right side included in kit)	1	29242
6	MAIN SHAFT, 1" DIA X 36.50"	1	VT-PI-43
7	T-NUT, ¼-20, SST, BAG OF TEN	1	14485
8	TORSION SPRING, LH	1	V3-SP-21
9	ACTUATOR, ROLLSTOP, LH	1	32958
10	ROLLSTOP ASSY, 4"X30"	1	33076
11	PIN, CLEVIS, 5/16X1-1/4, BAG OF TEN	1	19513
12	TORSION SPRING, RH	1	V3-SP-22
13	ACTUATOR, ROLLSTOP, RH	1	32957
14	KIT, LINK (YEL) & BRKTS (GRAY), HIGH MOUNT (left & right side included in kit)	1	31250
15	BRIDGEPLATE ASSY, INNER, 30"	1	32917
16	CATCH, BASE LATCH	1	V2-AC-103
17	KIT, BRKTS (GRAY), HIGH MOUNT (left & right side included in kit)	1	31251
18	LINK ASSY, FRONT PLATFORM	1	29222
19	WASHER, DELRIN, 1"ODX.38IDX.03 THK, BAG OF 10	1	25628
20	KIT, COLLAR, ROLLSTOP ACTUATOR, 6.25", W/HDWR	1	28775
21	KIT, FLANGED BEARING, 1" ID (KIT OF 10)	2	19579
22	BLOCK, PLATFORM LEVEL ADJ	2	VT-AH-142
23	SCREW, BUTTON HEAD, 5/16-18X1/2, SST, BLK OX, BAG OF 10	1	14484
24	SCREW HEX HEAD, 5/16-18X 1½, GR5, BAG OF 10	1	14403
25	SETSCREW, ½-20X1/4, W/NYLON INSERT, BAG OF 10	1	19704
26	BUMPER, VHMW, .75DX.38T	2	V2-AC-027
27	SCREW, PANHEAD, #8TEK X ½, BAG OF 10	1	15961
28	SCREW, BUTTON HEAD, 5/16-18 X ¾, SST, BAG OF 10	1	15983
29	WASHER, FLAT, .281 X .625 X .065, BAG OF 10	1	17504
30	BUSHING STEEL, .25ID X .32OD X.19L	1	V2-BU-003
31	SPACER, .25ID X .40OD X .2	2	33805
32	NUT, NYLON INSERT, ¼-20, BAG OF 10	1	15919
33	NUT, NYLON INSERT, 5/16-18, SST, BAG OF 10	1	14415
34	SCREW, HEX HEAD, ¼-20 X ¾, GR5, BAG OF 10	1	34578
35	SKI, LOWER, RH	1	32956
36	BUSHING, BRONZE	2	V2-BU-195
37	DECAL, REFLECTIVE, 3.0 X 18, RED & WHITE	2	33011
38	PLUG, MODIFIED, SQUARE	1	32918
39	CLAMP, 3/8ID, VINYL LINER	3	295-11121
40	SPRING, ROLLSTOP, TORSION	1	30589
41	MAGNET, SENSOR ASSEMBLY, ROLLSTOP	1	MM-400
42	SENSOR ASSEMBLY	1	32755
43	HARNESS, ROLLSTOP SENSOR	1	32710

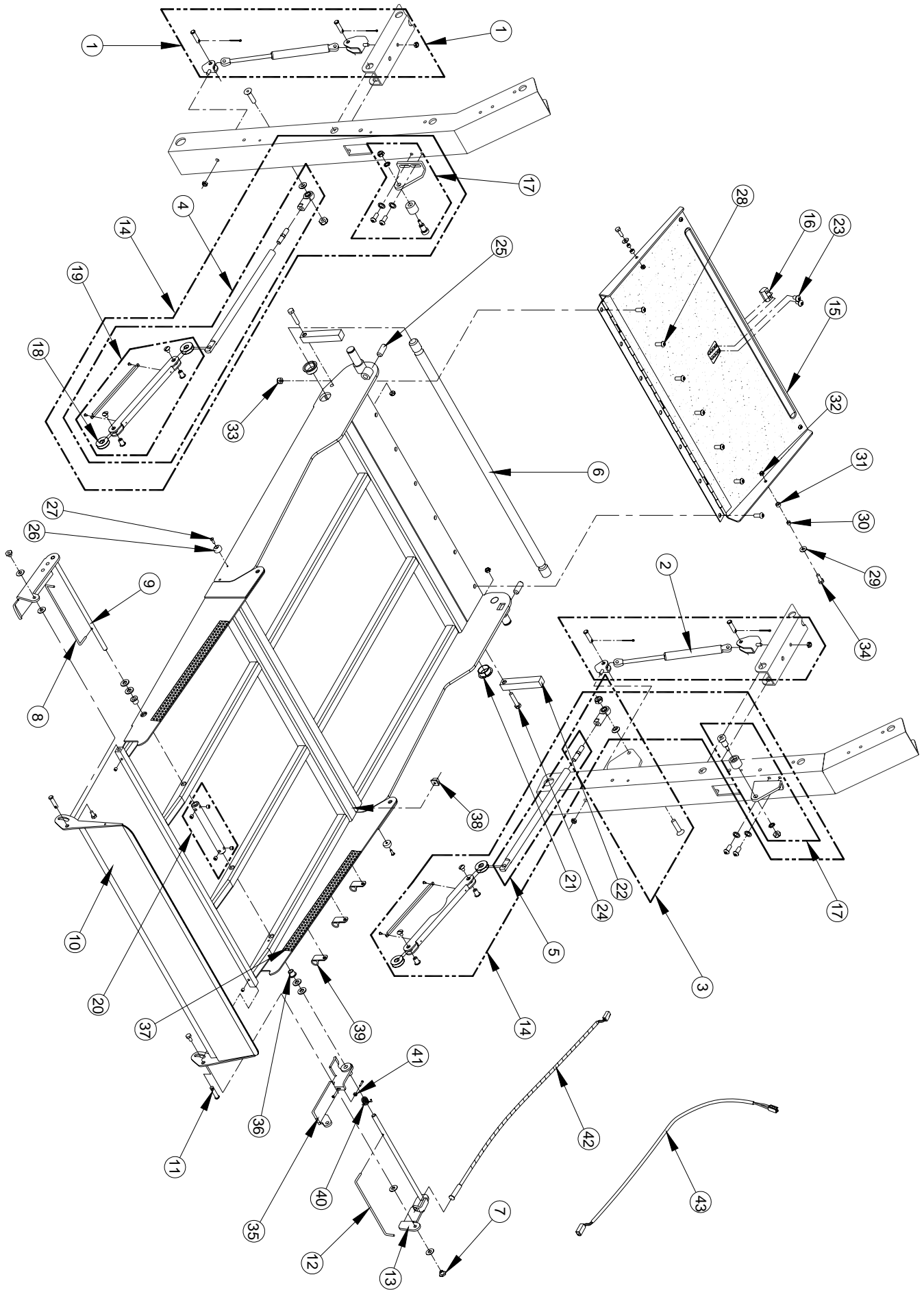

FIGURE 4-8: PRIVATE USE FOLDING PLATFORM ASSEMBLY, K1203

32DSSK04.A

FIGURE 4-8: PRIVATE USE FOLDING PLATFORM ASSEMBLY, K1203

REF	DESCRIPTION	QTY	PART NO.
1	KIT, PNEUMATIC SPRING ASSY, RETROFIT (left & right side included in kit)	2	19318
2	SPRING, PNEUMATIC ASSIST	2	R5-SP-502
3	ROD END ASSY, W/HDWR	2	29224
4	KIT, LINK ASSY	2	19522
5	KIT, LINK ASSY, REAR FOLDING PLATFORM (left & right side included in kit)	1	29243
6	MAIN SHAFT, 1" DIA X 36.50"	1	VT-PI-43
7	T-NUT, ¼-20, SST, BAG OF TEN	2	14485
8	TORSION SPRING, LH	1	V2-SP-021
9	ACTUATOR, ROLLSTOP, LH	1	32958
10	ROLLSTOP ASSY, 6"X30"	1	33823
11	PIN, CLEVIS, 5/16X1-1/4, BAG OF TEN	2	19513
12	TORSION SPRING, RH	1	V2-SP-022
13	ACTUATOR, ROLLSTOP, RH	1	32951
14	KIT, LINK (YEL) & BRKTS (GRA) (left & right side included in kit)	1	31253
15	BRIDGEPLATE ASSY, INNER, 30" PLATFORM	1	32917
16	CATCH, BASE LATCH	1	V2-AC-103
17	KIT, BRKTS W/ROLLER (left and right side included in kit)	1	31252
18	WASHER, DELRIN, 1" ODX .38ID, 0.03 THK, BAG OF 10	8	25628
19	LINK ASSY, FRONT PLATFORM	2	29223
20	KIT, COLLAR ROLLSTOP ACTUATOR, 6.25", W/HDWR	1	28775
21	KIT, FLANGED BEARING, 1" ID, KIT OF 10	2	19579
22	BLOCK, PLATFORM LEVEL ADJ	2	VT-AH-142
23	SCREW, BUTTON HEAD, 5/16-18X1/2, SST, BLK OX, BAG OF 10	2	14484
24	SCREW, HEX HEAD, 5/16-18X 1½, GR5, BAG OF 10	2	14403
25	SETSCREW, ½-20X1/4, W/NYLON INSERT, BAG OF 10	2	19704
26	BUMPER, VHMW, .75DX.38T	2	V2-AC-027
27	SCREW, PAN HEAD, #8TEK X ½, BAG OF 10	2	15961
28	SCREW, BUTTON HEAD, 5/16-18 X ¾ SST, BLK OX, BAG OF 10	7	15983
29	WASHER, FLAT, .281 X .625 X .065, BAG OF 10	2	17504
30	BUSHING STEEL, .25ID X .32OD X.19L	2	V2-BU-003
31	SPACER, .25ID X .40OD X .2	2	33805
32	NUT, W/NYLON INSERT, ¼-20, BAG OF 10	2	15919
33	NUT, W/NYLON INSERT, 5/16-18, SST, BAG OF 10	7	14415
34	SCREW, HEX HEAD, ¼-20 X ¾ GR5, BAG OF 10	2	34518
35	SKI, LOWER, RH	1	32956
36	BUSHING, BRONZE	2	V2-BU-195
37	DECAL, REFLECTIVE, 3.0 X 18, RED & WHITE	2	33011
38	PLUG, MODIFIED, SQUARE	1	32918
39	CLAMP, 3/8ID, VINYL LINER	3	295-11121
40	SPRING, ROLLSTOP, TORSION	1	30589
41	MAGNET, SENSOR ASSEMBLY, ROLLSTOP	1	MM-400
42	SENSOR ASSEMBLY	1	32755
43	HARNESS, ROLLSTOP SENSOR	1	32710

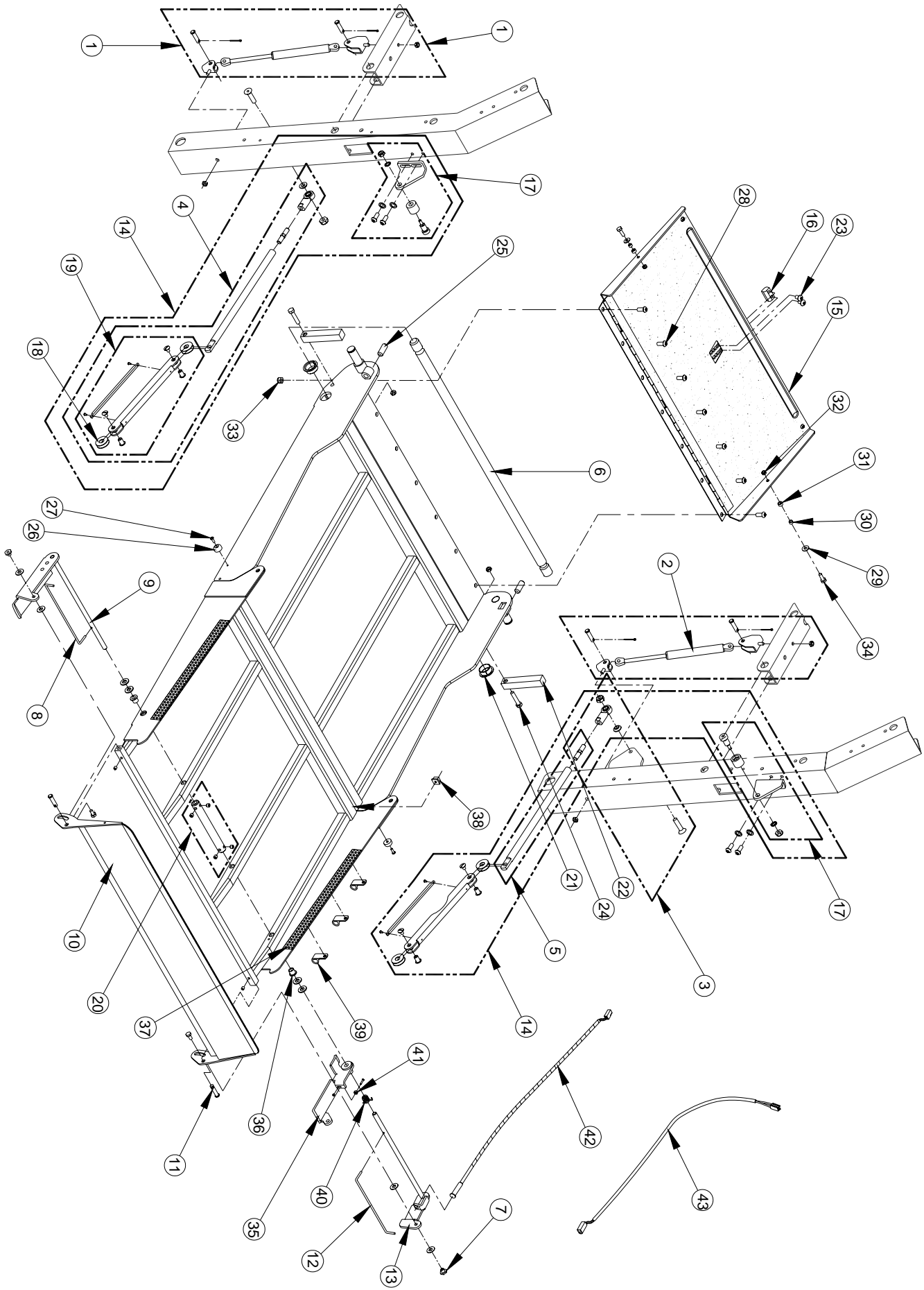

FIGURE 4-9: PRIVATE USE FOLDING PLATFORM ASSEMBLY, K1205

FIGURE 4-9: PRIVATE USE FOLDING PLATFORM ASSEMBLY, K1205

REF	DESCRIPTION	QTY	PART NO
1	KIT, PNEUMATIC SPRING ASSY, RETROFIT (left & right side included in kit)	2	19318
2	SPRING, PNEUMATIC ASSIST	2	R5-SP-502
3	ROD END ASSY, W/HDWR	2	29224
4	KIT, LINK ASSY	2	19523
5	KIT, LINK ASSY, REAR FOLDING PLATFORM (left & right side included in kit)	1	29243
6	MAIN SHAFT, 1" DIA X 39.13"	1	VT-PI-49
7	T-NUT, ¼-20, SST, BAG OF TEN	1	14485
8	TORSION SPRING, LH	1	V2-SP-021
9	ACTUATOR, ROLLSTOP, LH	1	32958
10	ROLLSTOP ASSY, 6"X32"	1	33824
11	PIN, CLEVIS, 5/16X1-1/4, BAG OF TEN	1	19513
12	TORSION SPRING, RH	1	V2-SP-022
13	ACTUATOR, ROLLSTOP, RH	1	32957
14	KIT, LINK (GRAY) & BRKTS (GRAY), RH & LH	1	31254
15	BRIDGEPLATE ASSY, INNER	1	33828
16	CATCH, BASE LATCH	1	V2-AC-103
17	KIT, BRACKETS W/ROLLER (left and right side included in kit)	1	31252
18	WASHER, DELRIN, 1" ODX.38IDX.03 THK, BAG OF 10	1	25628
19	LINK ASSY, FRONT PLATFORM	2	29222
20	KIT, COLLAR ROLLSTOP ACTUATOR, 6.25", W/HDWR	1	28775
21	KIT, FLANGED BEARING, 1" ID KIT OF 10	1	19579
22	BLOCK, PLATFORM LEVEL ADJ	2	VT-AH-142
23	SCREW, BUTTON HEAD, 5/16-18X1/2, SST, BAG OF 10	1	14484
24	SCREW, HEX HEAD, 5/16-18X1½, GR5, BAG OF 10	1	14403
25	SETSCREW, ½-20X1/4, W/NYLON INSERT, BAG OF 10	1	19704
26	BUMPER, VHMW, .75DX.38T	2	V2-AC-027
27	SCREW, PAN HEAD, #8TEK X ½, BAG OF 10	1	15961
28	SCREW, BUTTON HEAD, 5/16-18 X ¾ SST, BAG OF 10	1	15983
29	WASHER, FLAT, .28 X .625 X .065, BAG OF 10	1	17504
30	BUSHING STEEL, .25ID X .32OD X.19L	2	V2-BU-003
31	SPACER, .25ID X .40OD X .2	2	UV-PF-839
32	NUT, W/NYLON INSERT, ¼-20, BAG OF 10	1	15919
33	NUT, W/NYLON INSERT, 5/16-18, SST, BAG OF 10	1	14415
34	SCREW, HEX HEAD, ¼-20 X ¾, GR5, BAG OF 10	1	13308
35	SKI, LOWER, RH	1	32956
36	BUSHING, BRONZE	2	V2-BU-195
37	DECAL, REFLECTIVE, 3.0 X 18, RED & WHITE	2	33011
38	PLUG, MODIFIED, SQUARE	1	32918
39	CLAMP, 3/8ID, VINYL LINER	3	295-11121
40	SPRING, ROLLSTOP, TORSION	1	30589
41	MAGNET, SENSOR ASSEMBLY, ROLLSTOP	1	MM-400
42	SENSOR ASSEMBLY	1	32755
43	HARNESS, ROLLSTOP SENSOR	1	32710

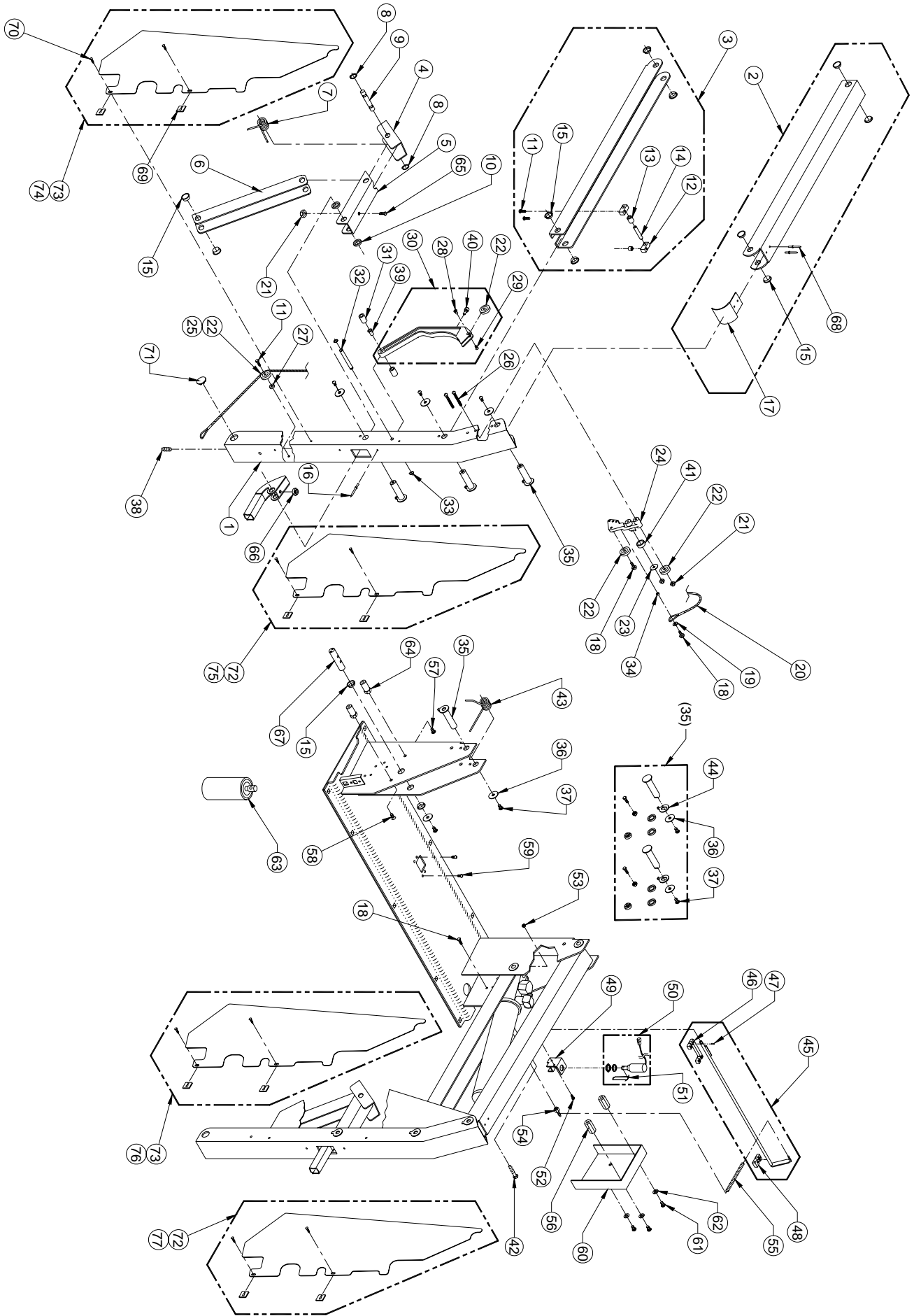

FIGURE 4-10: PRIVATE USE TRAVELLING FRAME
32DSSK04.A

FIGURE 4-10: PRIVATE USE TRAVELLING FRAME

REF	DESCRIPTION	QTY	PART NO
1	VERTICAL ARM ASSY, RH, K1100	1	21604
	VERTICAL ARM ASSY, LH, K1100	1	21605
	VERTICAL ARM ASSY, RH, K1200	1	15167
	VERTICAL ARM ASSY, LH, K1200	1	15166
2	TOP ARM ASSY	2	VS-AC-250
3	BOTTOM ARM ASSY	2	VS-AC-252
4	SADDLE ASSEMBLY	2	VT-AC-046
5	LINK, UPPER KNUCKLE LEVER ASSY	2	VT-AC-070
6	LINK, VERTICAL KNUCKLE ASSY, K1100	2	V1-AC-069
	LINK, VERTICAL KNUCKLE ASSY, K1200	2	VS-AC-069
7	SPRING, KNUCKLE ACTUATOR	2	VT-SP-42
8	RETAINING RING, .75" EXTERNAL, BAG OF 10	1	11796
9	PIN, SNAP RING, .75 OD X 2.15L	2	VT-PI-41
10	SPACER, KNUCKLE LINK	4	VT-BU-42
11	SCREW, BUTTON HEAD, 1/4-20 X 1", SST, BAG OF 10	1	19715
12	RETAINER, CAM ROLLER	4	V2-AC-025
13	ROLLER, INNER ROLLSTOP CAM	2	V2-AC-024
14	PIN, CAM ROLLER	2	V2-PI-094
15	FLANGED BUSHING, .75ID, BAG OF 10	1	19576
16	RIVET, BLIND, 3/16 X 1/2", ALUM, BAG OF 10	1	15918
17	CAP, UPPER PARALLEL ARM	2	V2-AC-89
18	SCREW, HEX HEAD, 1/4-20 x 3/4, BAG OF 10	1	13308
19	WASHER, FLAT, .63OD x .28ID x .065, BAG OF 10	1	17504
20	KIT, INNER ROLLSTOP CABLE, K1100	1	13661
	KIT, INNER ROLLSTOP CABLE, K1200	1	16093
21	NUT, HEX ¼-20, W/NYLON INSER, BAG OF TEN	1	15919
22	BEARING, GROOVED	8	VS-AH-06
23	WASHER, FENDER, ¼"X1" OD, BAG OF TEN	1	25623
24	BLOCK, PULLEY MOUNT, INNER ROLLSTOP	2	V2-AC-112
25	BEARING, 1" OD, GROOVED, .25ID	2	25374
26	SCREW, BUTTON HEAD, 1/4-20 x 2 1/4, SST, BAG OF 10	1	19720
27	BUSHING, 5/8 OD X 3/16L	2	VS-AH-13
28	T-NUT, FLAT HEAD, 10-24 X .25 OD X .44L	2	V2-AC-015
29	SCREW, FLAT HEAD, 10-24 x ½, BAG OF 10	1	13303
30	CAM ASSY, INNER ROLLSTOP ACTUATOR	2	V2-AC-190
31	KIT, SPACER, RUBBER, INNER ROLLSTOP CAM (KIT OF 4)	1	01224
32	PIN, SNAP RING, .38OD X 3.09L	2	VS-PI-09
33	RETAINING RING, .38ID, BAG OF 10	1	11795
34	BUSHING, STEEL, 251D X 320D X .19L	2	V2-BU-003
35	KIT, RETROFIT, PIN, LINK, ARM ASSY	6	16679
36	WASHER, FENDER, 5/16, SST, BAG OF TEN	1	15921
37	SCREW, BUTTON HEAD, 5/16-18X½, SST, BAG OF TEN	1	14494
38	SET SCREW, 3/8-16X3/8", CUP POINT	1	11797
39	BEARING, NYLINER, 3/8 IDX11/16 LONG	2	25562
40	BUMPER, BUTTON, IRS CAM, BAG OF 10	1	19783
41	BUMPER, IRS CAM, ANTI-RATTLE	2	V2-BU-090
42	SCREW, HEX HEAD, 1/4-20 X 1-3/4, BAG OF 10	1	25696
43	SPRING, UPPER PARALLEL ARM	2	V2-SP-97

FIGURE 4-10: PRIVATE USE TRAVELLING FRAME

REF	DESCRIPTION	QTY	PART NO
44	WASHER, KEYED	2	20258
45	KIT, LATCH RELEASE, 26", w/BLOCKS & HDWR	1	28767
	KIT, LATCH RELEASE, 30", w/BLOCKS & HDWR	1	28768
46	BLOCK, CENTER MOUNTING, BASE LATCH	1	V2-AC-102
47	DOWEL PIN, .094 DIA X .38 L, BAG OF 10	1	25615
48	BLOCK, MOUNTING, BASE LATCH	1	V2-AC-001
49	BRACKET, STOW LOCK SOLENOID	1	V2-AC-108
50	SOLENOID ASSY, 12V, STOW LOCK	1	V2-ES-127
51	CLIP, SPRING, BASE LATCH	1	V2-AC-009
52	SCREW, FLAT HEAD, 10-24 x 1/2, SST, BAG OF 10	1	14426
53	NUT, HEX, NYLON INSERT, 10-24, BAG OF 10	1	13382
54	PIN, SPRING MOUNTING	1	V2-PI-095
55	SPRING, DOOR HELPER .38OD X 3.5"	1	V2-SP-093
56	BUSHING, LATCH COVER	2	V2-BU-080
57	SCREW, HEX HEAD, 5/16-18 X 3/4", BAG OF 10	1	15901
58	SCREW, FLAT HEAD, 5/16-18X3/4, BAG OF 10	1	14499
59	SCREW, BUTTON HEAD, 1/4-20X1/2", SST, BAG OF TEN	1	15902
60	COVER, BASE LATCH	1	V2-CV-123
61	SCREW, HEX HEAD, 5/16-18 X .625, BAG OF 10	1	14495
62	WASHER, FLAT, .69OD x .34ID x .065, BAG OF 10	1	13350
63	SPRAY PAINT, TOUCH-UP, CHARCOAL	1	25340
64	BUSHING, E-COVER MOUNT	2	V2-BU-081
65	SCREW, HEX HEAD, 1/4-20X1, BAG OF TEN	1	14493
66	GROMMET, .30ID x .88OD x .44, BAG OF 10	1	23391
67	PIN, CONTROL CAM	1	V2-PI-091
68	RIVET, BLIND, 3/16ODX5/8L, STEEL, BAG OF 10	1	34519
69	SPRING NUT, 10-24, U-TYPE, BAG OF 10	1	11799
70	SCREW, PAN HEAD, 10-24 x 1/2, BAG OF 10	1	13304
71	PLUG, 1" LOW PROFILE, BLACK NYLON	2	25563
72	KIT, PINCH POINT SHIELD, LH INSIDE AND RH OUTSIDE, W/HDWR, K1100	2	29183
73	KIT, PINCH POINT SHIELD, LH OUTSIDE AND RH INSIDE, W/HDWR, K1100	2	29167
74	KIT, PINCH POINT SHIELD, LH OUTSIDE, W/HDWR, K1200	1	29162
75	KIT, PINCH POINT SHIELD, LH INSIDE, W/HDWR, K1200	1	29165
76	KIT, PINCH POINT SHIELD, RH INSIDE, W/HDWR, K1200	1	29181
77	KIT, PINCH POINT SHIELD, RH OUTSIDE, W/HDWR, K1200	1	29178

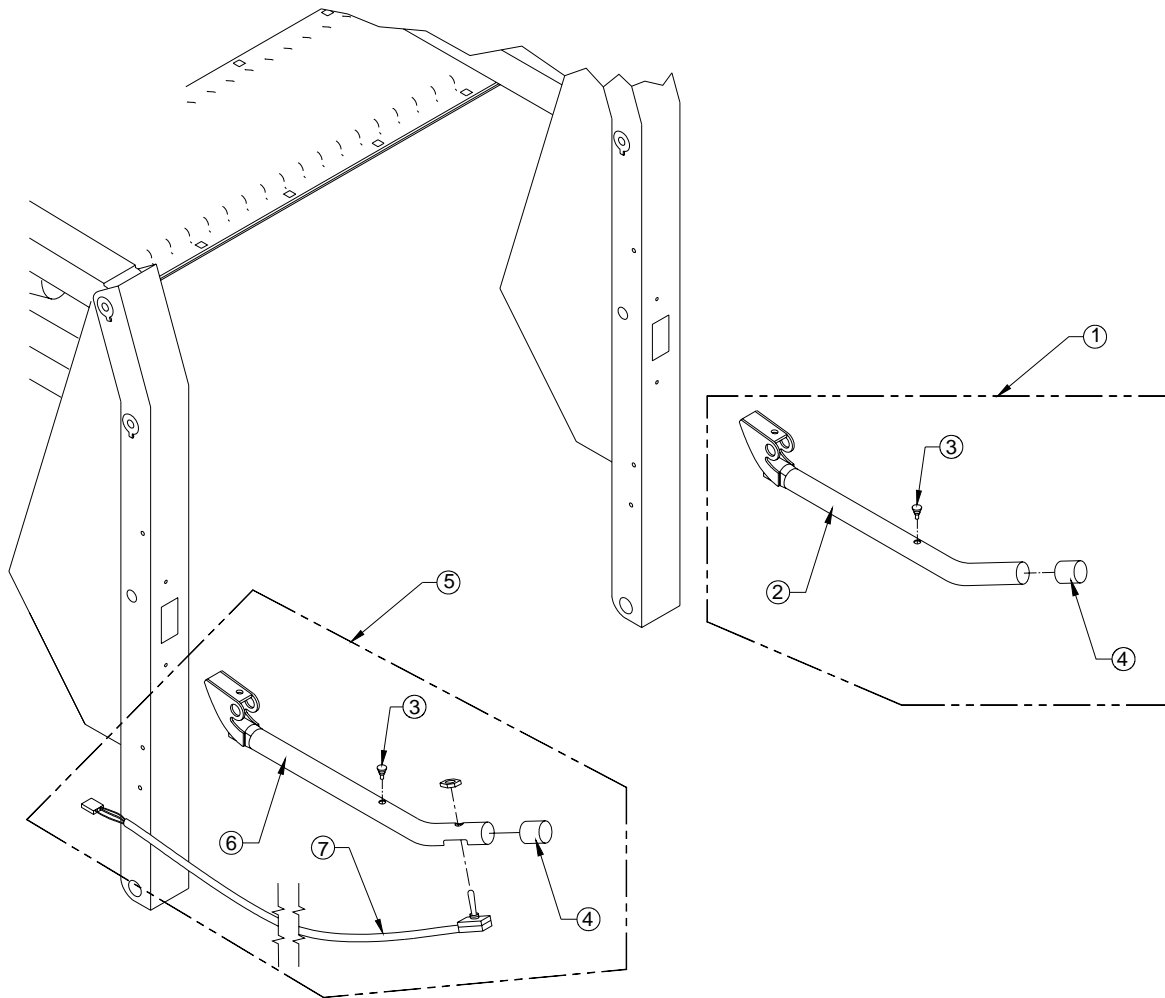

FIGURE 4-11: PRIVATE USE HANDRAILS

FIGURE 4-11: PRIVATE USE HANDRAILS			
REF	DESCRIPTION	QTY	PART NO
1	HANDRAIL ASSEMBLY, RH	1	VS-AC-159
2	HANDRAIL, RH	1	VS-AC-181
3	RUBBER BUMPER, BAG OF 10	1	20653
4	CAP, BLACK	2	25550
5	HANDRAIL ASSEMBLY, LH, W/HARNESS	1	VS-AC-160
6	HANDRAIL, LH	1	VS-AC-182
7	HARNESS, ARM SWITCH	1	V2-ES-012

APPENDIX 1 LIFT SPECIFICATIONS

K-SERIES PRIVATE USE PLATFORM LIFT

Power..... electro-hydraulic
 Motor rating @ 12 volts DC 65.0 amp. avg/cycle, 1250 psi
 @ 24 volts DC 32.5 amp. avg/cycle, 1250 psi
 Hydraulic cylinders 2 ea, 1.5", power-up/gravity-down

Rated load capacity 600 lbs
 Manual backup (up)..... hand pump
 Manual backup (down) pressure release valve
 Lift weight 340 - 370 lbs

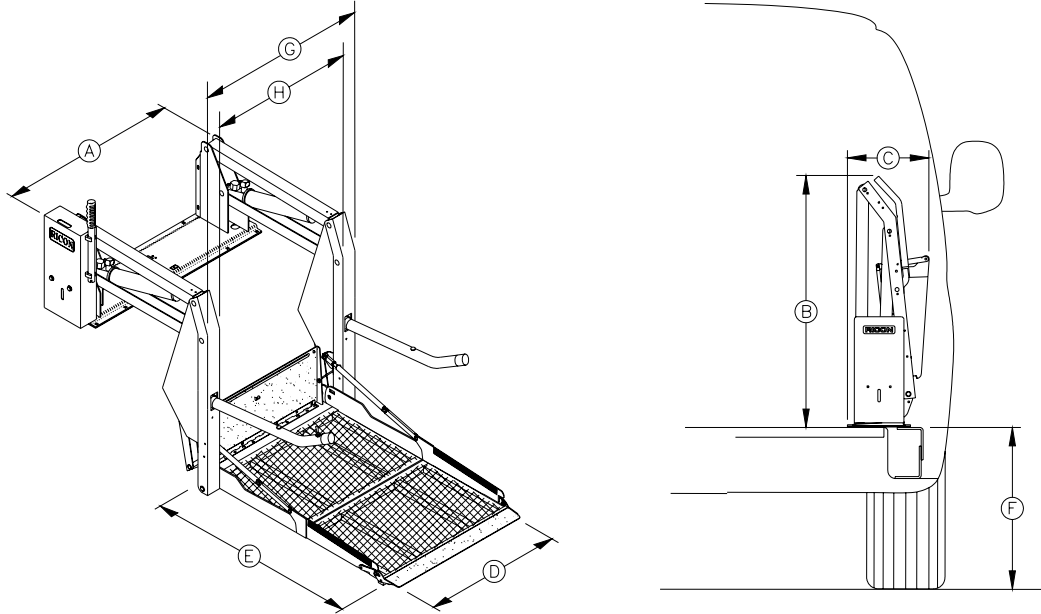

DIMENSIONS (inches)

	A	B	C	D	E	F	G	H
MODEL	Stationary frame width	Height (folded)	Installation depth (folded)	Usable platform width	Usable platform length	Floor-to-ground travel	Traveling frame width	Clear entry width
K1132	43	38.6	15.5	26	38	24	33.5	29.25
K1200	47	38.5	15.5	30	44	28	37.5	29.25
K1203	47	43.6	15.5	30	51	28	37.5	29.25
K1205	49	43.6	15.5	32	51	28	39.5	31.25

