

IV. S-SERIES EXPORT PARTS DIAGRAMS AND LISTS

This chapter contains parts diagrams and parts lists for the RICON S-Series Export Use Wheelchair and Standee Lift with Folding Platform. The exploded view of each major lift assembly shows individual components referenced by numbers. On each associated parts list is the reference number, a part description, the quantity used and the Ricon part number. For part numbers of lift decals, refer to the "Decal Locations and Part Numbers" figure in Chapter II of this manual.

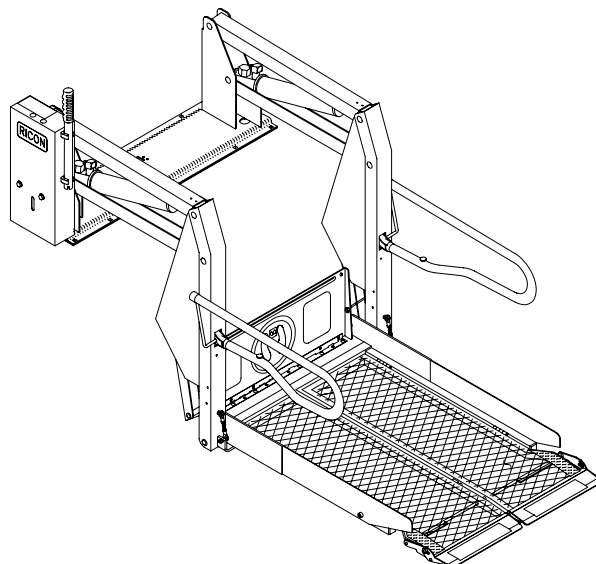

NOTE: To order a part: locate the part or assembly on an exploded view, note its reference number, find this number on the associated parts list (following page), and order the part number in the far right column. Most kits contain a single part (plus hardware). Therefore, you may need to order more than one kit if the part is used more than once on a major assembly.

NOTE: Some major lift components that are typically painted gray may also be available in other colors, such as red, yellow, and blue. These include the platform assembly, handrails, vertical arms, top and bottom arms, and baseplate assembly.

LIFT MODEL AND KIT NUMBERS	
PRODUCT NUMBER	S2030-E1000000 (first model in number sequence)
DOCUMENTATION KIT NUMBER	01074
PRODUCTION DECAL SET NUMBER	SXXXXLEXXXXXXXX
SPARE DECAL KIT NUMBER	26013

PARTS DIAGRAM PAGE

FIGURE 4-1: MONARCH HYDRAULIC POWER UNIT #1	4-2
FIGURE 4-2: S-SERIES HYDRAULIC SYSTEM	4-6
FIGURE 4-3: S-SERIES ELECTRICAL SYSTEM	4-8
FIGURE 4-4: S-SERIES PENDANT	4-10
FIGURE 4-5: S-SERIES SPLIT PLATFORM	4-12
FIGURE 4-6: S-SERIES TRAVELING FRAME	4-16
FIGURE 4-7: S-SERIES STANDEE HANDRAIL (EXPORT)	4-20
LIFT SPECIFICATIONS	4-23

**FIGURE 4-1: MONARCH HYDRAULIC POWER UNIT #1
S-SERIES (ALL MODELS) WHEELCHAIR LIFT
SERIAL NO's. 31000 - 31999
SERIAL NO's. 35000 - PRESENT**

REF.	DESCRIPTION	QTY.	PART NO.
1	SCREW,10-24 X ½ PAN HEAD, SELF THREAD	3	28111T
2	SOLENOID, SPST, 12V	1	20668
3	SOLENOID, SPST, 24V	1	26449
4	HARNESS, PUMP, w/DOOR INTERLOCK, (S/N's 32000-95999)	1	V2-ES-100
	HARNESS, PUMP, w/DOOR INTERLOCK, (SN 96000 - present)	1	10069
5	HARNESS, PUMP, w/o DOOR INTERLOCK, (S/N's 32000-95999)	1	V2-ES-150
	HARNESS, PUMP, w/o DOOR INTERLOCK, (SN 96000 - present)	1	10335
6	NUT, NYLON INSERT, 10-24, (BAG OF 10)	3	13382
7	KIT,SOLENOID,12V,DBL POLE,w/HDWR	1	20670
	KIT,SOLENOID,24V,DBL POLE,w/HDWR	1	20669
8	BUS BAR, MOTOR, SP SOLENOID, (S/N's 52456-95999) (DISCONTINUED)	1	V2-ES-034
	BUS BAR (SN 96000 - present)	1	10807
9	BUS BAR, MOTOR, DP SOLENOID, (S/N's 32000-95999) (DISCONTINUED)	1	UV-ES-040
10	BUS BAR (SN 96000 - present)	1	13087
11-1	MOTOR ASSY, 12V, 3", MONARCH PUMP (P/N V2-SH-115 DISCONTINUED)	1	14345
11-2	MOTOR ASSY, 24V, 3", MONARCH PUMP (P/N V2-ES-116 DISCONTINUED)	1	14346
11-3	MOTOR ASSY, 12V ISKRA (SN 96000 - present) (DISCONTINUED)	1	14332
	MOTOR ASSY, w/BRACKET, 12V ISKRA	1	14345
11-4	MOTOR ASSY, 24V ISKRA (SN 96000 - present) (DISCONTINUED)	1	14333
	MOTOR ASSY, w/BRACKET, 24V ISKRA	1	14346
12	FITTING ASSY, ELBOW, #4 STD THD X #4 JIC, w/HDWR	1	18235
13	DECELERATION VALVE ASSY	1	V2-SH-279
14	PLUG, 3/4-16 CAVITY, w/O-RING (DISCONTINUED)	2	V2-SH-001
15	KIT, PRESSURE SWITCH, W/INSTRUCTIONS (P/N 16640 SUPERSEDED)	1	42050
16	PLUG w/O-RING	1	V2-SH-182
17	LIGHT ASSY, INDICATOR, 12V (P/N 15207 DISCONTINUED)	1	19067
18-1	SPOOL VALVE ASSY, 12V, ADA APPLICATIONS	1	01176
18-2	SPOOL VALVE ASSY, 24V, ADA APPLICATIONS	1	01177
19	RESERVOIR, PUMP, PLASTIC w/DECAL & PLUG	1	30938
20	PLUG, BREATHER, RESERVOIR,	1	V2-SH-106
21	HOSE CLAMP	1	V2-SH-109
22-1	VALVE ASSY, POPPET, DELTROL, 12V	1	V2-SH-105
22-2	VALVE ASSY, POPPET, DELTROL, 24V (DISCONTINUED)	1	V2-SH-136
23	SEAL KIT, MANUAL BACK-UP PUMP	1	V2-SH-220
24	BACK-UP PUMP, MANUAL (S/Ns 6000-30,999 & 32,000-31,999)	1	V2-SH-110
24-1**	BACK-UP PUMP, MANUAL (S/Ns 31,000-31,999 & 35,000-present)	1	V2-SH-210
25	FITTING ASSY, SNL, 1/4J X 1/4J, STEEL	1	VS-SH-06
26-1	CABLE CLAMP, 3/8", NYLON, (BAG OF 10)	1	18660
26-2	CABLE CLAMP, 3/16", NYLON, (BAG OF 10)	1	19798
26-3	CABLE CLAMP, 5/16", NYLON, (BAG OF 10)	1	19772
26-4	CABLE CLAMP, ½", NYLON, (BAG OF 10)	1	19774
27	CIRCUIT BREAKER, 8 AMP, w/HDWR & DECAL	1	V2-SH-005
28	CIRCUIT BREAKER, 30 AMP, w/HDWR	1	26510
29-1	BRACKET, SOLENOID MOUNTING (S/N's 32000-95999)	1	V2-SH-127
29-2	BRACKET, SOLENOID ISKRA (S/N 96000-)	1	10507
30	HANDLE, MANUAL BACK-UP PUMP	1	V2-SH-111
31	JUMPER, DPDT SOLENOID, BLK, 10GA, 5.0"	1	ELJ00121
32	JUMPER, DPDT SOLENOID w/ISOLATED GROUND, BLK, 10GA, 5.5"	1	ELJ00122
33	JUMPER, DPDT SOLENOID, RED, 10GA, 5.5"	1	ELJ02055
34	JUMPER, DPDT SOLENOID, ORG, 18GA, 5.0"	1	ELJ03061
35	DIODE BLOCK ASSEMBLY	1	08232
36	PIN & RETAINING RING	2	V2-SH-017
37-1	KIT, PUMP MOTOR BRUSH SET (inside motor) (S/N's 32000-95999) (DISCONTINUED)	1	V2-SH-115B
37-2	KIT, PUMP MOTOR BRUSH SET (located inside motor) (S/N 96000 - present)	1	14334
38	DECAL, 8 AMP CIRCUIT BREAKER (DISCONTINUED)	1	26290
39	ADAPTER, .625 D-HOLE TO .484 ROUND	1	V2-ES-059
40	WASHER, FLAT, 7/16 (S/N's 61878 - present) (BAG OF 10)	1	19716

REF.	DESCRIPTION	QTY.	PART NO.
41	BRACKET, TENSION LINK, MONARCH PUMP	1	V2-SH-149
42-1	JUMPER, SWITCH, PRESSURE, RH PUMP	1	15860
42-2	JUMPER, SWITCH, PRESSURE, LH PUMP	1	19091
43	DECAL, OIL LEVEL WARNING	1	32-10-154
44	SCREW, SHC, 1/4-20X2.5 (BAG OF 10)	3	32407
45	FITTING, SRT, 1/4J, STEEL	1	V2-SH-012
46**	KIT, RETROFIT, 2nd SOLENOID, 12V	1	19068
47**	KIT, RETROFIT, 2nd SOLENOID, 24V	1	19843
48**	HARNESS, EXT, RH PUMP	1	V2-ES-155
49-1	LIGHT, LIFT ARMED INDICATOR, 12V (S/N's 61878 - present)	1	UL-ES-034
49-2	LIGHT, LIFT ARMED INDICATOR, 24V (S/N's 61878 - present)	1	V2-ES-016

** Item not shown.

This page intentionally left blank.

S-SERIES HYDRAULIC SYSTEM
SERIAL NO's. 32000 - PRESENT

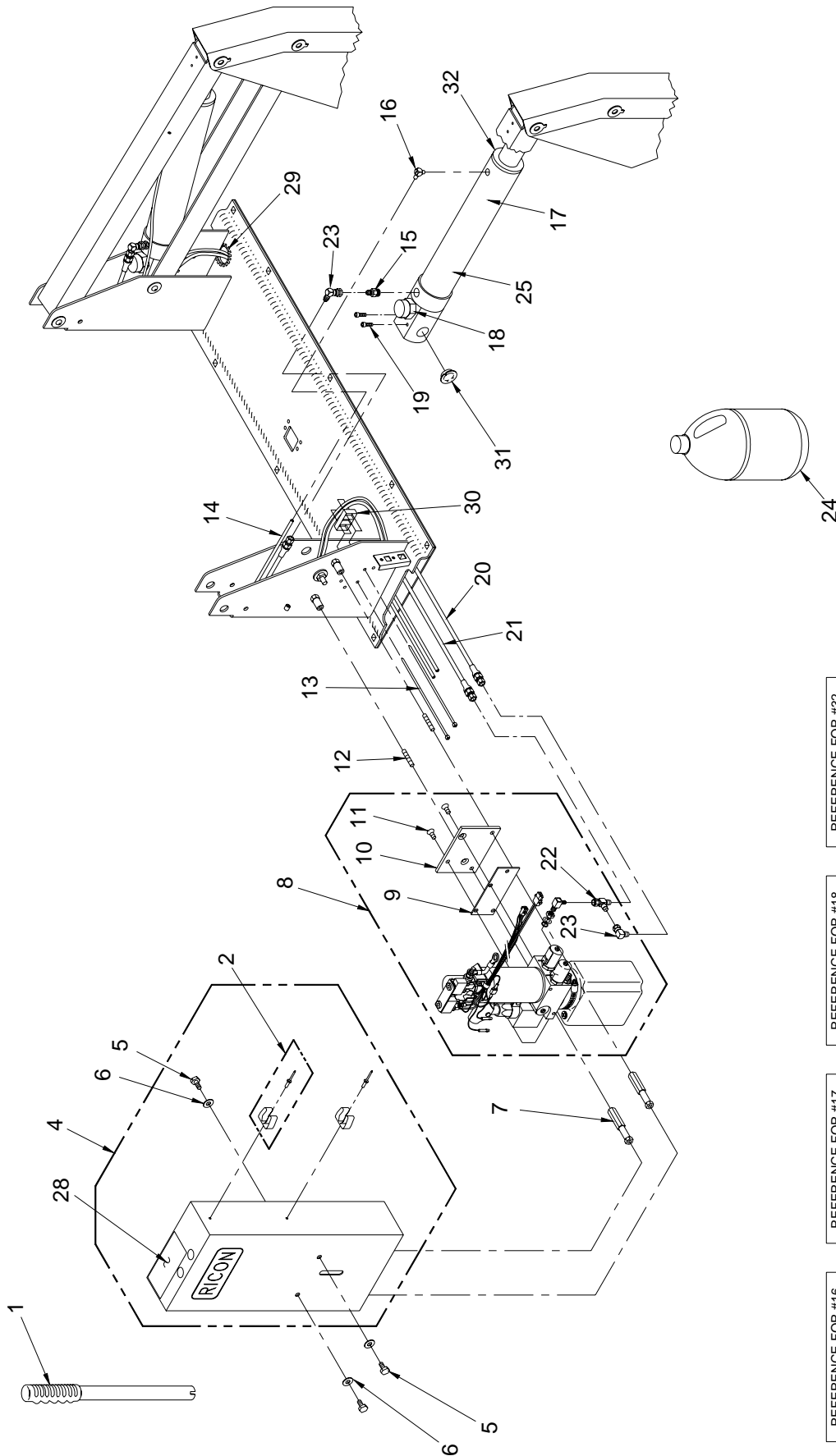

REFERENCE FOR #16		"L" FITTING, MALE, 10-32 X 1/4 BARB
REFERENCE FOR #17		REBUILD KIT, HYDRAULIC CYLINDER
REFERENCE FOR #18		FLOW CONTROL, PRESSURE COMPENSATED, FIXED RATE
REFERENCE FOR #32		GLAND NUT, 1.50", WITH SEAL

FIGURE 4-2: S-SERIES HYDRAULIC SYSTEM

**FIGURE 4-2: S-SERIES HYDRAULIC SYSTEM
(ALL MODELS) WHEELCHAIR LIFT
SERIAL NO's. 32000 – PRESENT**

REF.	DESCRIPTION	QTY.	PART NO.
1	HANDLE, MANUAL BACKUP PUMP	1	V2-SH-111
2	KIT, TOOL CLIP, W/HDWR	2	19557
4-1	COVER, PUMP, RH (SN's 31000-31999 & 35000- present)	1	V2-CV-221
4-2	COVER, PUMP, LH (S/N's 31000-31999 & 35000-present)	1	V2-CV-220
4-3	COVER, PUMP, LH (S/N's 6000-31000) (DISCONTINUED)	1	V2-CV-021
5	SCREW, HEX HEAD, 5/16-18 X .625 (BAG OF 10)	3	14495
6	WASHER, FLAT, 5/16", SAE (BAG OF 10)	1	13350
7	HEX ROD, PUMP STANDOFF	2	V2-CV-015
8-1	S-SERIES PUMP, 12V, NOTOP, UV RES, 2KPSI	1	PM212002007
8-2	S-SERIES PUMP, 12V, w/INTLK & ANTIDRIFT (DISCONTINUED)	1	PM212090110
8-3	S-SERIES PUMP, 12V, w/COMMON BRACKET (s/n's 31000 - 31999 & 35000 - present)	1	PM212090100
8-4	S-SERIES PUMP, 24V, w/COMMON BRACKET (s/n's 31000 - 31999 & 35000 - present)	1	PM224110100
8-5	S-SERIES PUMP, 12V, w/COMMON BRACKET (s/n's 32000 - 34999)	1	PM212090100
8-6	S-SERIES PUMP, 24V, w/COMMON BRACKET (s/n's 32000 - 34999)	1	PM224110100
8-7	S-SERIES PUMP, 12V, COM BRKT, w/o INTLK, RH, DCL	1	PM212090308
8-8	S-SERIES PUMP, 24V, COM BRKT, w/o INTLK, RH, DCL	1	PM224100108
9	PLATE, PUMP COVER MOUNT	1	V2-AC-71
10	PLATE, PUMP MOUNTING	1	V2-AC-70
11	SCREW, FLAT HEAD, 5/16-18 X 3/4" (BAG OF 10)	2	14499
12	STUD, THREADED, 5/16-18 X 1.75" (BAG OF 10)	2	14500
13	CABLE TIE, 5.5", BLACK (BAG OF 10)	2	25697
14	TUBE, POLYURETHANE, 6MM x 4MM, BLACK	9'	22-02-230
15-1	ADAPTOR, STRAIGHT, 1/4 NPT MALE (S/N's 32000-63999)	2	V2-SH-84
15-2	ADAPTOR, # 6 SAE MALE X # 4 JIC MALE (S/N's 64000 - present)	2	26591
16	FITTING, "L", MALE 10-32 X 1/4 BARB	2	V2-SH-16
17	KIT, CYLINDER REPAIR, W-PISTON ASSY, GLAND NUT AND SEAL	2	21829
18	KIT, FLOW CONTROL, PRESSURE COMPENSATED, FIXED RATE (KIT OF 2)	2	30968
19	SCREW, HEX HEAD, 1/4-20 X 1, BAG OF 10	4	14491
20	HOSE ASSY, 61" X 1/4 JIC X 1/4 JIC	1	V2-SH-009
21	HOSE ASSY, 26" X 1/4 JIC X 1/4 JIC	1	V2-SH-008
22	FITTING, RUN TEE, 1/4 JIC M-M-F	1	V2-SH-012
23	FITTING, "L", 1/4 JIC M-F SWIVEL	3	VS-SH-06
24	OIL, HYDRAULIC, TEXACO #15, MEETS MIL-H-5606G	1 GAL	20-16-051
25-1	CYLINDER ASSY, S-1200	2	VS-SH-105
25-2	CYLINDER ASSY, S-2000	2	VT-SH-105
25-3	CYLINDER ASSY, S-5000	2	V5-SH-105
28	DECAL, MANUAL OPERATION (TOP, w/CB)	1	26214
29	GROMMET, CATERPILLAR, 3/16"	8.5"	26647
30	SPACER, CABLE AND HOSE	2	25557
31	BUSHING, 3/4"ID X 3/8W	4	25381
32	GLAND NUT AND SEAL (SUPERSEDED)	2	21829

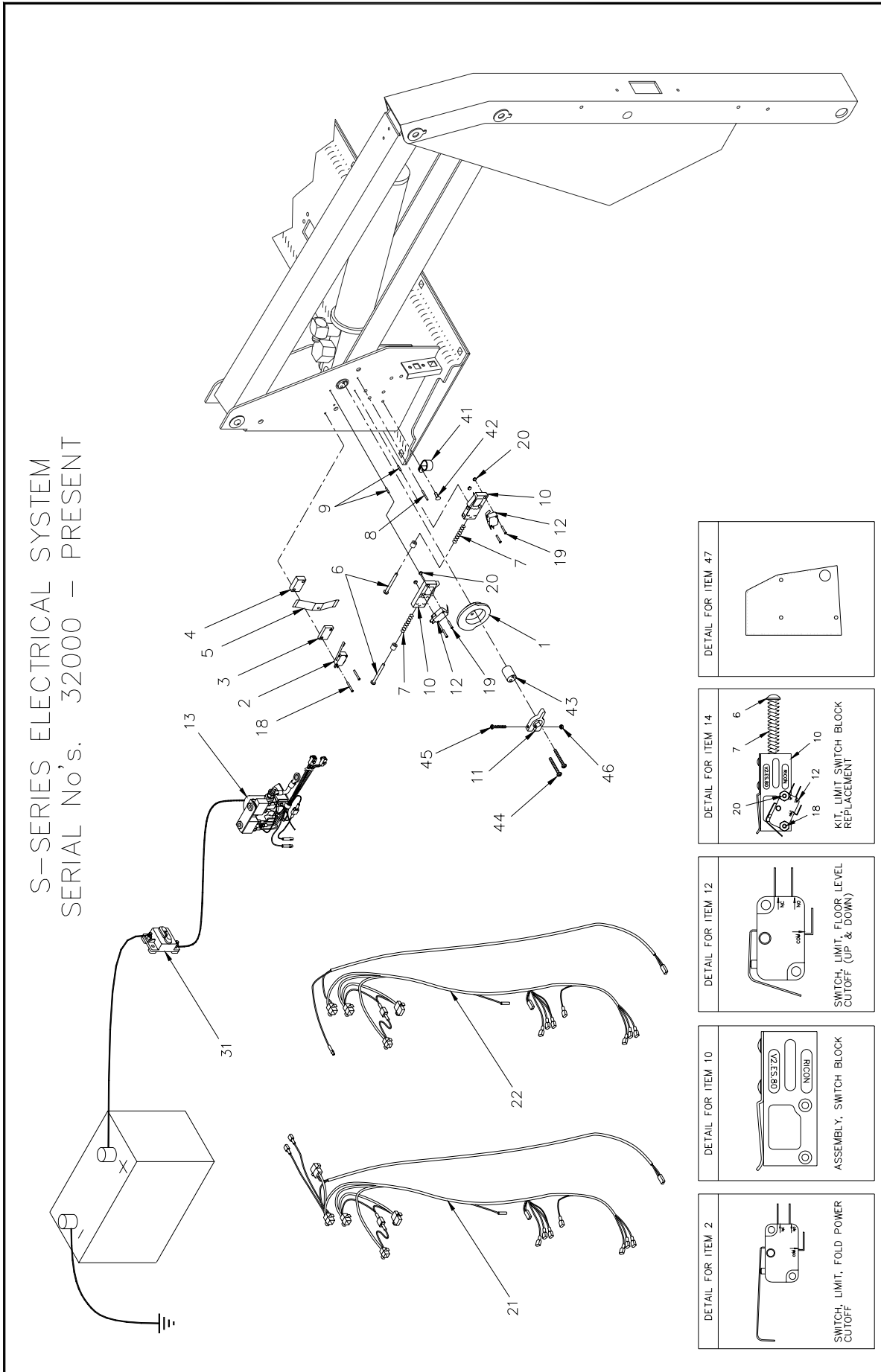

FIGURE 4-3: S-SERIES ELECTRICAL SYSTEM

**FIGURE 4-3: S-SERIES ELECTRICAL SYSTEM
(ALL MODELS) SERIAL NO's. 32000 - PRESENT**

REF.	DESCRIPTION	QTY.	PART NO.
1-1	CAM, LIFT CONTROL w/SET SCREW (S/N's 32000-62559)	1	V2-ES-99
1-2	CAM, LIFT CONTROL (S/N's 62560 - present)	1	V2-AC-107
2	SWITCH, LIMIT, FOLD POWER CUTOFF	1	V2-ES-111
3	BLOCK, FOLD CUTOFF SWITCH OFFSET, 1/4" THICK	1	V2-ES-78
4	BLOCK, FOLD CUTOFF SWITCH OFFSET, 3/8" THICK	1	V2-ES-79
5	SPRING, RETAINING, UPPER/LOWER SWITCH BLOCK	1	V2-ES-95
6	SCREW, ROUND HEAD, 10-24 X 2" (ADJUSTING) (BAG OF 10)	2	14497
7	SPRING, COMPRESSION, .30 OD X 2.06L	2	V2-ES-93
8	ROLL PIN, .94 X 1 (TIMING PIN) (BAG OF 10)	1	14498
9	ROLL PIN, .94 X .50 (SWITCH BLOCK MOUNT) (BAG OF 10)	2	14496
10	SWITCH BLOCK ASSY, (UPPER & LOWER)	2	34314
11-1	KIT, RETRO, CAM (S/N's 32000-62559 P/N V2-BU-89 DISCONTINUED)	1	01287
11-2	ACTUATOR, FOLD CUTOFF (S/N's 62560 - present)	1	V2-AC-089
12	SWITCH, LIMIT, FLOOR LEVEL POWER CUTOFF (UP & DOWN)	2	V2-ES-110
13	COMPONENTS, SOLENOID BRACKET (for replacement parts, refer to hydraulic power unit parts list drawing	—	—
14	KIT, LIMIT SWITCH BLOCK REPLACEMENT	2	V2-ES-61
18	SCREW, 4-40 X 1.25 PAN HEAD (BAG OF 10)	2	15908
19	SCREW, 4-40 X .75 PAN HEAD (BAG OF 10)	4	15909
20	NUT, HEX, 4-40 (BAG OF 10)	4	15903
21	ELECTRICAL HARNESS, MAIN, w/DOOR OPERATOR INTERCONNECT	1	V2-ES-051
22	ELECTRICAL HARNESS, MAIN, w/o DOOR OPERATOR INTERCONNECT	1	V2-ES-050
31	CIRCUIT BREAKER, MAIN	1	01010K
41	CLAMP, CABLE, 11/16" (S/N's 53168 - present)	1	255161
42	MS, 10-24 X 1/2 PHIL PAN (BAG OF 10)	1	13304
43	PIN, EXTENSION FOLD CUTOFF (S/N's 62560 - present) (BAG OF 10)	1	15914
44	MS 10-24 X 1 3/4 PHIL PAN (S/N's 62560 - present) (BAG OF 10)	2	15915
45	MS 8-32 X 1 1/4 PHIL PAN (S/N's 62560 - present) (BAG OF 10)	1	15906
46	NUT-HEX 8-32 NYLON INSERT (S/N's 62560 - present) (BAG OF 10)	1	15907
47 *	COVER, ELEC SYSTEM	1	V2-CV-110

* Used for left hand installation only.

S-SERIES PENDANT

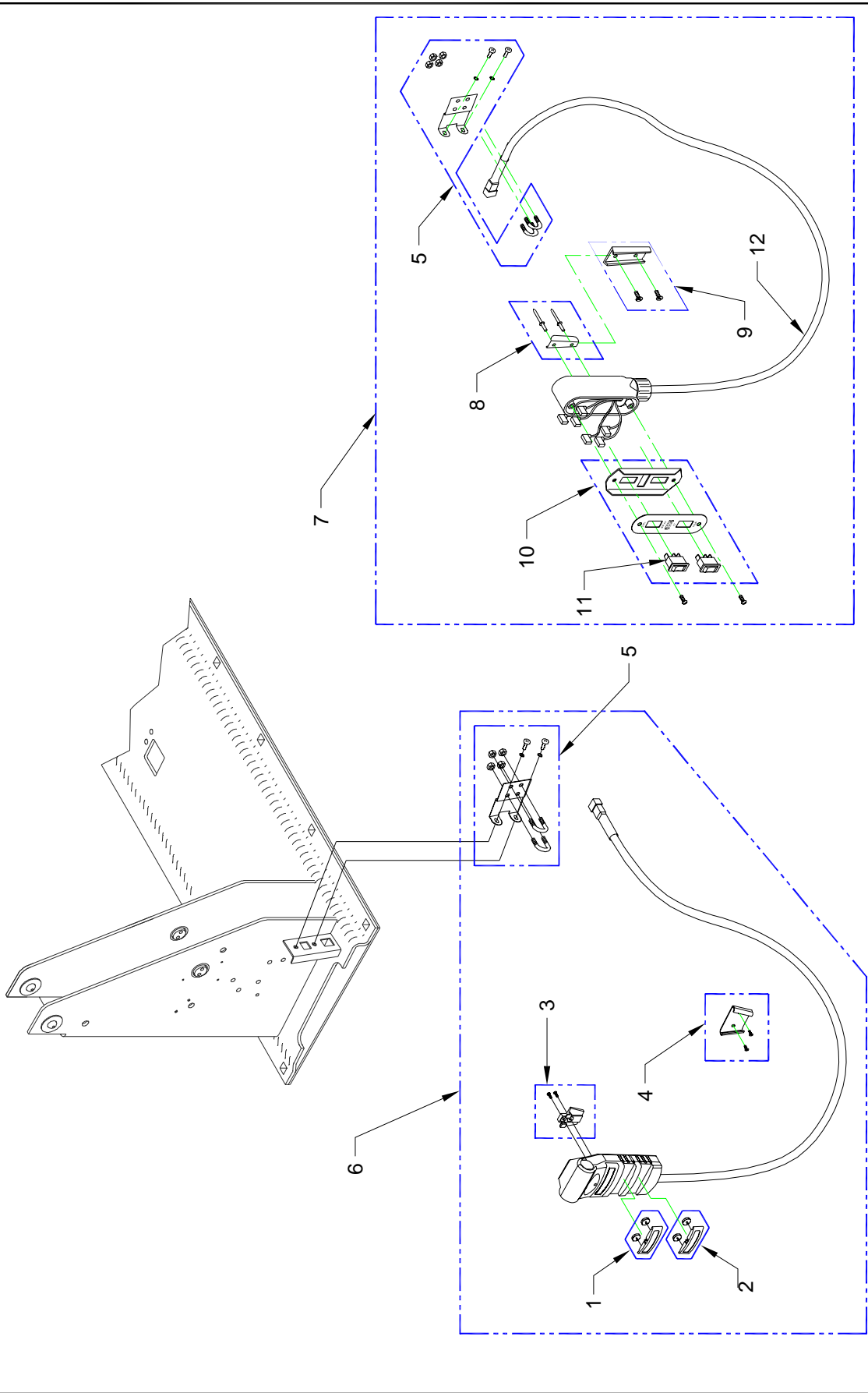

FIGURE 4-4: S-SERIES PENDANT

FIGURE 4-4: S-SERIES PENDANT

REF.	DESCRIPTION	QTY.	PART NO.
1	SPARE PARTS, STOW/DEPLOY BUTTON, S-SERIES	1	14731
2	SPARE PARTS, UP/DOWN BUTTON, S-SERIES	1	14732
3	SPARE PARTS, V-BRACKET, PLASTIC	1	14733
4	KIT, WALL MOUNT BRACKET, UNIVERSAL PENDANT	1	14709
5	KIT, CONTROL HARNESS STRAIN RELIEF, S-SERIES	1	01007
6-1	KIT, PENDANT, S-SERIES, 7 FT	1	14727
6-2	KIT, PENDANT, S-SERIES, COILED CORD	1	14728
6-3	KIT, PENDANT, S-SERIES, 10 FT	1	14729
6-4	KIT, PENDANT, S-SERIES, STEEL JACKETED CORD	1	14730
7	KIT, PENDANT, OLD-STYLE (W/ROCKER SWITCH)	1	01008
8	KIT, CLIP, PENDANT, MALE W/RIVETS	1	28781
9	KIT, INSTL, PENDANT MTG CLIP	1	01118
10	FACEPLATE ASSY, PENDANT, SWITCH GD	1	V2-ES-035
11	SWITCH, SP ROCKER, ON-OFF-ON BLK	2	26455
12	HARNESS REPLACEMENT, 7FT CORD (FOR 01008 ONLY-OLD STYLE PENDANT)	1	V2-ES-024

DATE: 06/01/04
DWC: SSX00006

S-SERIES SPLIT PLATFORM
SERIAL NO's. 32000 -

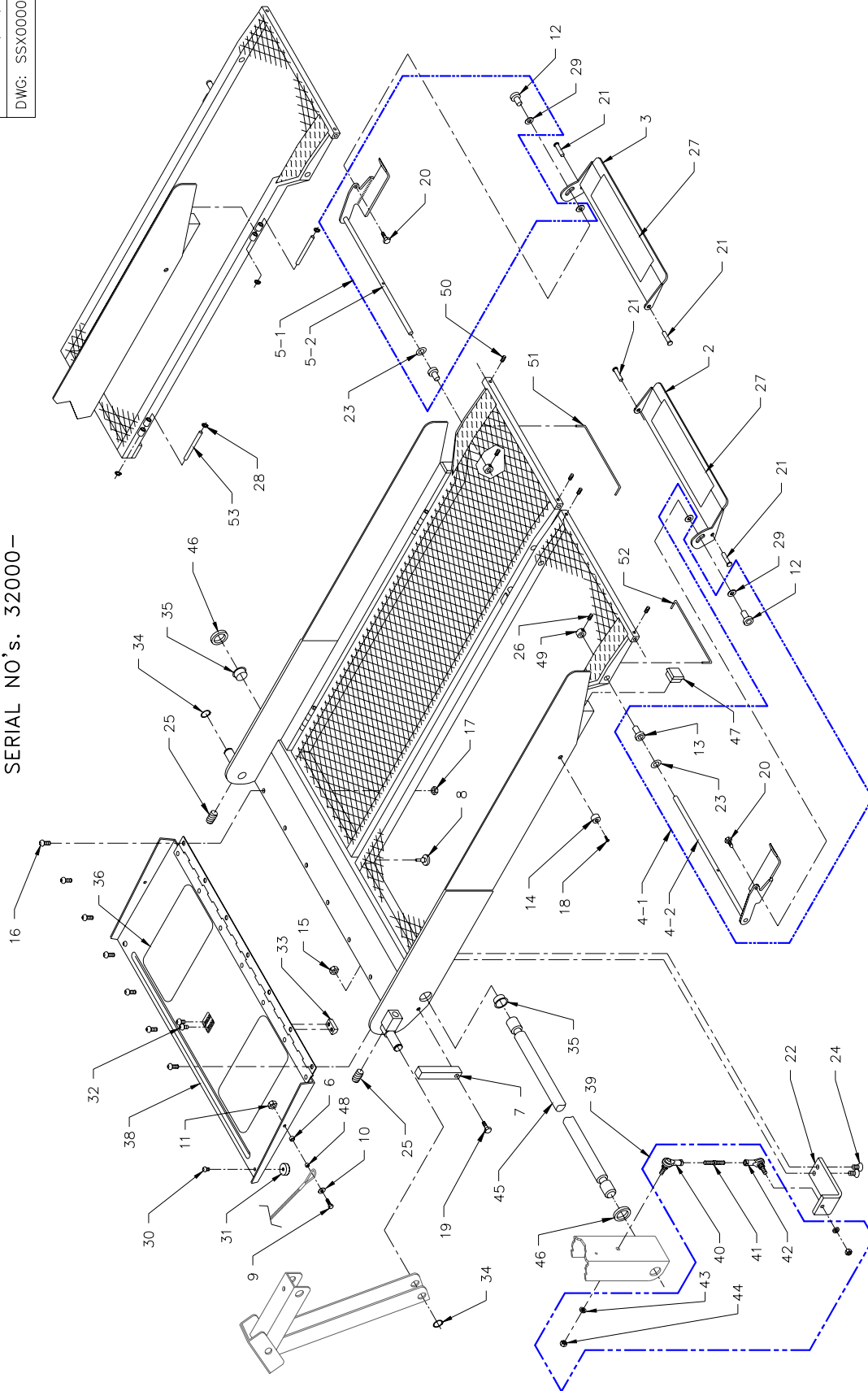

FIGURE 4-5: S-SERIES SPLIT PLATFORM

**FIGURE 4-5: S-SERIES SPLIT PLATFORM
EXPORT WHEELCHAIR LIFT (SERIAL NO'S. 32000 – PRESENT)**

REF.	DESCRIPTION	QTY.	PART NO.
1-1*	PLATFORM ASSY, SPLIT, 30 X 42	1	V2-PF-380
1-2 *	PLATFORM ASSY, SPLIT, 30 X 48	1	V2-PF-381
1-3 *	PLATFORM ASSY, SPLIT, 26 X 38, S1100	1	V1-PF-380
1-4 *	PLATFORM ASSY, SPLIT, 30 X 38, S1100	1	V1-PF-381
2-1	ROLLSTOP ASSY, LH, SPLIT PLATFORM, 30"	1	V2-PF-122
2-2	ROLLSTOP ASSY, LH, SPLIT PLATFORM, S1132, 26"	1	V1-PF-122
3-1	ROLLSTOP ASSY, RH, SPLIT PLATFORM, 30"	1	V2-PF-123
3-2	ROLLSTOP ASSY, RH, SPLIT PLATFORM, S1132, 26"	1	V1-PF-123
4-1	KIT, REPLACEMENT, ROLLSTOP ACTUATOR, LH, W/HDWR	1	22903
4-2	ROLLSTOP ACTUATOR ASSY, LH, S1132	1	V1-PF-003
5-1	KIT, REPLACEMENT, ROLLSTOP ACTUATOR, RH, W/HDWR	1	22902
5-2	ROLLSTOP ACTUATOR ASSY, RH, S1132	1	V1-PF-002
6	SPACER, ROLLSTOP	2	UV-PF-839
7	BLOCK, PLATFORM LEVEL ADJUSTMENT	2	VT-AH-142
8	BUMPER, RUBBER (BAG OF 10)	2	20653
9	SCREW, HEX HEAD, 1/4-20 X 7/8" (BAG OF 10)	2	15920
10	WASHER, FLAT, .64OD X .28ID X.065 (BAG OF 10)	2	17504
11	NUT, HEX, 1/4-20, NYLON INSERT (BAG OF 10)	2	15919
12	"T" NUT, SST (BAG OF 10)	2	14485
13	BUSHING, BRONZE, .39 ID	2	V2-BU-195
14	BUMPER, UHMW PLASTIC, 75 D X .38 T	2	V2-AC-027
15	NUT, HEX, NYLON INSERT, 5/16-18 (BAG OF 10)	2	13349
16	SCREW, BUTTON HEAD, 5/16-18 X 1/2", SST (BAG OF 10)	7	17506
17	NUT, HEX, 5/16-18 (BAG OF 10)	7	19714
18	SCREW, TEK PAN HEAD, #8 X 3/4" (BAG OF 10)	2	15911
19	SCREW, HEX HEAD, 5/16-18x1, GR5 (BAG OF 10)	2	15953
20	SCREW, HEX HEAD, 1/4-20 x 1/2", GR5 (BAG OF 10)	2	34518
21	PIN, CLEVIS, 5/16 x 1-1/4, (BAG OF 10)	2	19513
22	ATTACHMENT, RODEND, GRAY	2	36279
23	WASHER, FLAT, .81OD X .41ID x .065 (BAG OF 10)	2	17510
24	SCREW, FLAT HEAD, 3/8-16 x 3/4" (BAG OF 10)	4	11792
25	SET SCREW, 1/2-20 X 1-1/4" (ADJUSTING SCREW), (BAG OF 10)	2	19704
26	SET SCREW, 1/4-20 x 1/4", CUP POINT (BAG OF 10)	2	13312
27	SAFETREAD, 2.75" X 14"	2	V2-AC-41
28	RING, RETAINING, .25"OD (BAG OF 10)	8	11793
29	WASHER, NYLON, .318 ID X .751 OD X .031 (BAG OF 10)	4	14467
30	SCREW, BUTTON HEAD, 1/4-20 X 3/8, SST (BAG OF 10)	2	13309
31	GUIDE, 1.00 OD X 1/4-20 ID X 0.33	2	UL-AC-034
32	SCREW, BUTTON HEAD, 5/16-18 X 1/2, SST (BAG OF 10)	2	17506
33-1	KIT, REPLACEMENT LATCH MECHANISM	1	01099
33-2	CATCH, BASE LATCH (44720 - present)	1	V2-AC-103
34	RETAINING RING, EXT, .75" (BAG OF 10)	2	11796
35	BUSHING, FLANGED, 1" ID X 1/2W" (BAG OF 10)	2	19579
36	SAFETREAD, 9.75 X 5.50, BLACK	2	25653
38-1	INNER ROLLSTOP, 30" ASSY	1	V2-PF-141
38-1	KIT, INNER ROLLSTOP RETROFIT W/HDWR	1	01029
38-2	INNER ROLLSTOP, 26" ASSY	1	V1-PF-212
39	ASSEMBLY, TIE ROD	2	VS-AH-08
40	BALL JOINT, RH THREAD	2	VS-AH-03
41	STUD, TIE ROD, LH THREAD TO RH THREAD	2	VS-AH-07
42	BALL JOINT, LH THREAD, SST	2	VS-AH-02
43	WASHER, SPLIT LOCK, 5/16" (BAG OF 10)	4	13384
44	NUT, HEX, 5/16-24 (BAG OF 10)	4	15988
45-1	SHAFT, MAIN, PLATFORM, 1" X 37.25	1	VT-PI-43
45-2	SHAFT, MAIN, PLATFORM, 1" X 33.25	1	VS-PI-14
46	SHIM, PVC	2	V2-BU-091
47	PLUG, SQUARE, 1 1/8, BLACK PLASTIC	2	10258
48	BUSHING, STEEL, .25ID X .32OD X .19L	2	V2-BU-003
49	COLLAR, .39ID	2	VS-BU-02
50	SET SCREW, 1/4-20 X 1/4, CONE POINT (BAG OF 10)	4	14492

51	SPRING, TORSION, RH	1	V3-SP-22
52	SPRING, TORSION, LH	1	V3-SP-21
53	PIN, HINGE, SPLIT PLATFORM DOOR (ONLY FOR 30 X 48 SPLIT PLATFORM)	4	VS-PI-01

* Fully assembled platform with all items shown in Figure 4-6, except items 45 and 46.

This page intentionally left blank.

S-SERIES TRAVELING FRAME
SERIAL NO's. 32000 - PRESENT

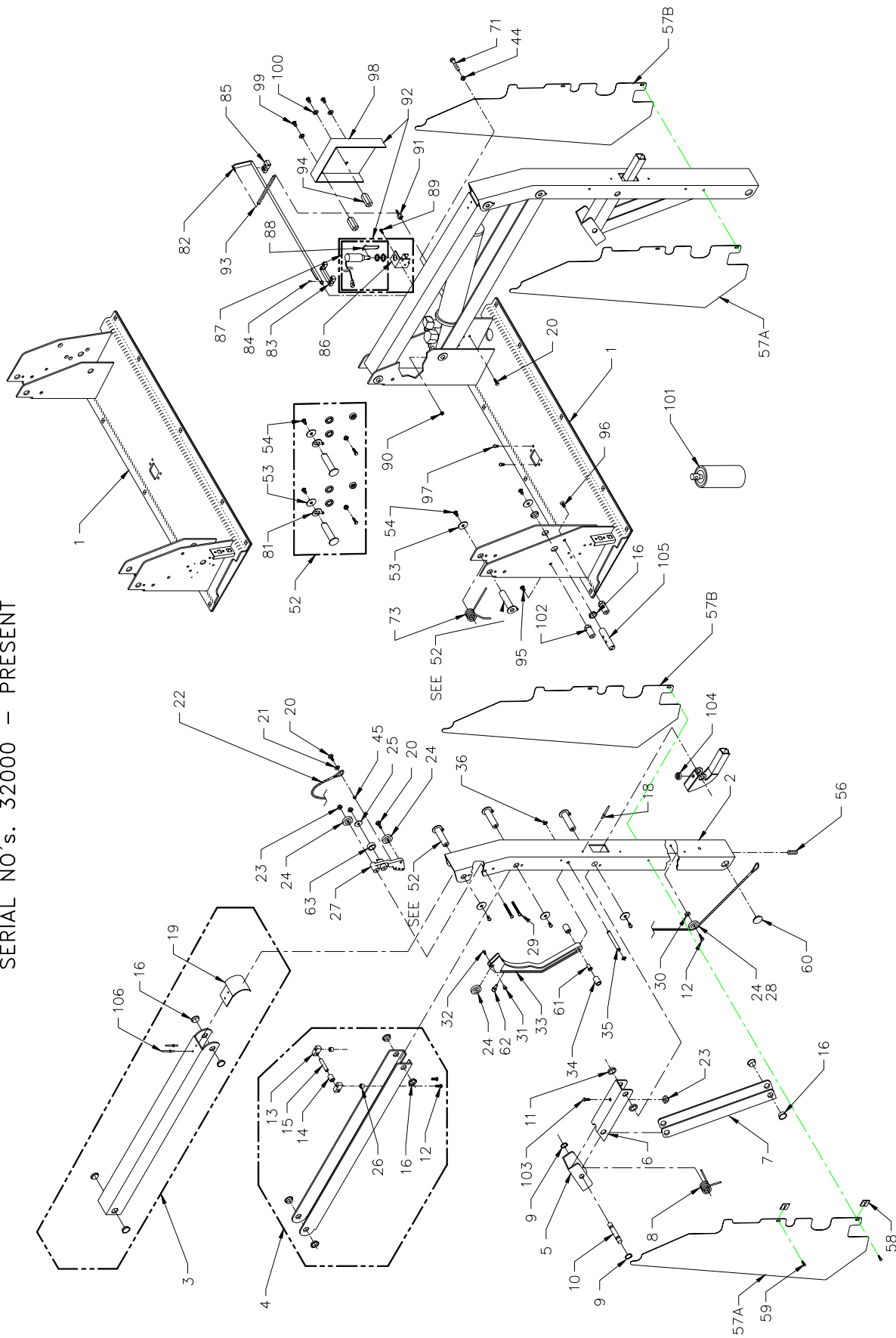

FIGURE 4-6: S-SERIES TRAVELING FRAME

**FIGURE 4-6: S-SERIES TRAVELING FRAME
(ALL MODELS) WHEELCHAIR LIFT SERIAL NO's. 32000 - PRESENT**

REF.	DESCRIPTION	QTY.	PART NO.
1-1	BASEPLATE ASSY, 26", w/INTERLOCK, S1100	1	14450
1-2	BASEPLATE ASSY, 30", w/o INTERLOCK	1	14452
	BASEPLATE ASSY, 30", w/INTERLOCK	1	14453
	BASEPLATE ASSY, 30", w/o INTERLOCK, RH	1	14452R
	BASEPLATE ASSY, 30", w/INTERLOCK, S1100	1	14451
1-3	BASEPLATE ASSY, 32", w/o INTERLOCK	1	14454
	BASEPLATE ASSY, 32" w/INTERLOCK	1	14455
	BASEPLATE ASSY, 32" ,w/o INTERLOCK, RH	1	14454R
2-1	VERTICAL ARM ASSY, RH, S1200	2	VS-AC-241
	VERTICAL ARM ASSY, LH, S1200	2	VS-AC-242
2-2	VERTICAL ARM ASSY, S2000	2	VT-AC-141
	VERTICAL ARM ASSY, S5000	2	V5-AC-141
2-3	VERTICAL ARM ASSY, RH, S1100, (S/N's 32000-62043)	2	V1-AC-241
	VERTICAL ARM ASSY, LH, S1100, (S/N's 62044 - present)	2	V1-AC-242
3-1	TOP ARM ASSY, S1200	2	VS-AC-250
3-2	TOP ARM ASSY, S2000	2	VT-AC-250
3-3	TOP ARM ASSY, S5000	2	V5-AC-250
4-1	BOTTOM ARM ASSY, S1200	2	VS-AC-252
4-2	BOTTOM ARM ASSY, S2000	2	VT-AC-252
4-3	BOTTOM ARM ASSY, S5000	2	V5-AC-252
5	SADDLE ASSEMBLY	2	VT-AC-046
6	LINK KNUCKLE LEVER ASSY	2	VT-AC-070
7-1	LINK, VERTICAL KNUCKLE ASSY, S1200, w/LOAD SENSOR	1	VS-AC-058
7-2	LINK, VERTICAL KNUCKLE ASSY, S2000, w/LOAD SENSOR	1	VT-AC-058
7-3	LINK, VERTICAL KNUCKLE ASSY, S5000, w/LOAD SENSOR	1	V5-AC-058
7-4	LINK, VERTICAL KNUCKLE ASSY, S1100, w/LOAD SENSOR, SOLID PLATFORM	1	V1-AC-058
7-5	LINK, VERTICAL KNUCKLE ASSY, S1100, w/LOAD SENSOR, SPLIT PLATFORM	1	V1-AC-158
7-6	LINK, VERTICAL KNUCKLE ASSY, S1200, w/o LOAD SENSOR	2**	VS-AC-069
7-7	LINK, VERTICAL KNUCKLE ASSY, S2000, w/o LOAD SENSOR	2**	VT-AC-069
7-8	LINK, VERTICAL KNUCKLE ASSY, S5000, w/o LOAD SENSOR	2**	V5-AC-069
7-9	LINK, VERTICAL KNUCKLE ASSY, S1100, w/o LOAD SENSOR, SOLID PLATFORM	2**	V1-AC-069
7-10	LINK, VERTICAL KNUCKLE ASSY, S1100, w/o LOAD SENSOR, SOLID PLATFORM	2**	V1-AC-071
8-1	SPRING, KNUCKLE ACTUATOR (S/N's 31999 AND BELOW)	2	VT-SP-45
8-2	SPRING, KUNCKLE ACTUATOR (S/N's 32000 - present)	2	VT-SP-42
9	RETAINING RING, .75" EXT (BAG OF 10)	1	11796
10	PIN, SNAP RING, 0.75 OD X 2.15L	2	VT-PI-41
11	SPACER, KNUCKLE LINK	4	VT-BU-42
12	SCREW, BUTTON HEAD, 1/4-20 X 1", SST (BAG OF 10)	1	19715
13	RETAINER, CAM ROLLER	4	V2-AC-025
14-1	ROLLER, BRIDGEPLATE CAM (S2000 & S5000)	2	V2-AC-124
14-2	ROLLER, BRIDGEPLATE CAM (S1000 & S1200)	2	V2-AC-024
15	PIN, CAM ROLLER	2	V2-PI-094
16	FLANGED BUSHING, .75ID (BAG OF 10)	3	19576
18	RIVET, BLIND, 3/16 X 1/2", ALUM (BAG OF 10)	1	15918
19	CAP, UPPER PARALLEL ARM	2	V2-AC-89
20-1	SCREW, HEX HEAD, 1/4-20 x 3/4, GR5 (BAG OF 10)	4	13308
20-2	SCREW, FLAT HEAD, 1/4-20 x 1/2 (BAG OF 10)	1	15928
21	WASHER, FLAT HEAD, .63OD x .28ID x .065 (BAG OF 10)	2	17504
22-1	CABLE ASSY, REPLACEMENT, BRIDGEPLATE, S1200, 49.50"	2	16093
22-2	CABLE ASSY, REPLACEMENT, BRIDGEPLATE, S2000, 52.50"	2	16094
22-3	CABLE ASSY, REPLACEMENT, BRIDGEPLATE, S5000, 55.50"	2	16095
22-4	CABLE ASSY, REPLACEMENT, BRIDGEPLATE, S1100, 45.00"	2	13661
23	NUT, HEX, 1/4-20, NYLON INSERT (BAG OF 10)	2	15919
24	BEARING, GROOVED	8	VS-AH-06
25	WASHER, FENDER, 1.00OD x .28ID x .065 (BAG OF 10)	2	25623
26	STAND OFF, .38 LG, 1/4" ID X 1/2" OD	4	V2-AC-011
27	BLOCK, PULLEY MOUNT, IRS	2	V2-AC-112
28	BEARING, GROOVED, 1" OD, .25 ID, S1100 only, (S/N's 62044 - present)	2	25374

* Item 7 is used on serial no.'s 103,999 and below.

REF.	DESCRIPTION	QTY.	PART NO.
29	SCREW, BUTTON HEAD, 1/4-20 x 2 1/4, SST, BLK OXIDE (BAG OF 10)	1	19720
30	BUSHING, 5/8 OD X 3/16L	2	VS-AH-13
31	T-NUT, FLAT HEAD, 10-24 X .25 OD X .44L	2	V2-AC-015
32	SCREW, FLAT HEAD, 10-24 x 1/2 (BAG OF 10)	1	13303
33	CAM, ASSY, BRIDGEPLATE ACTUATOR	2	V2-AC-190
34	KIT, SPACER, RUBBER, BRIDGEPLATE CAM	4	01224
35	PIN, SNAP RING, .38OD X 3.09 L	2	VS-PI-09
36	RETAINING RING, .38ID (BAG OF 10)	1	11795
45	BUSHING, STEEL, 251D X 320D X .19L	2	V2-BU-003
51	PIN, LINK ARM	6	16679
52	KIT, RETROFIT, PIN, LINK, ARM ASSY	3	16679
53	WASHER, FENDER, 5/16, SST (BAG OF 10)	1	15921
54	SCREW, BUTTON HEAD, 5/16-18 X 1/2 SST (BAG OF 10)	1	14494
56	SETSCREW, 3/8-16 x 3/8, CUP PT (BAG OF 10)	1	11797
57A	KIT, PINCH POINT SHIELD W/HDWR, S2030, S2034 & S2035	2	29162
57A	KIT, PINCH POINT SHIELD W/HDWR, S5030	2	29163
57B	KIT, PINCH POINT SHIELD W/HDWR, S2030, S2034, S2035	2	29178
57B	KIT, PINCH POINT SHIELD W/HDWR, S5030	2	29179
58	SPRING NUT, 10-24, U-TYPE (BAG OF 10)	1	11799
59	SCREW, PAN HEAD, 10-24 x 1/2 (BAG OF 10)	1	13304
60	PLUG, 1" LOW PROFILE, BLK NYLON (S/N's 52246 - present)	2	25563
61	BEARING, NYLINER, 3/8 ID 11/16 LONG (S/N's 56000 - present)	2	25562
62	BUMPER, BUTTON, BRIDGEPLATE CAM, (BAG OF 10)	1	19783
63	BUMPER, BRIDGEPLATE CAM, ANTI-RATTLE (S/N's 56000 - present)	2	V2-BU-090
71	SCREW, HEX HEAD, 1/4-20 X 1-3/4, GR5 (BAG OF 10)	1	25696
73	SPRING, UPPER PARALLEL ARM	2	V2-SP-97
80	SETSCREW, 5/16-18 x 1, CUP PT (BAG OF 10)	1	15830
81	WASHER, KEYED, PAINTED	2	20258
82-1	KIT, LATCH RELEASE, 30", w/BLOCKS & HDWR	1	28768
82-2	KIT, LATCH RELEASE, 26", w/BLOCKS & HDWR	1	28767
83-1	BLOCK, MOUNTING, BASE LATCH, (S/N's 32000 - 44719)	2	V2-AC-001
83-2	BLOCK, CENTER MOUNTING, BASE LATCH (S/N's 44720 - present)	1	V2-AC-102
84	DOWEL PIN, .094 DIA X .38 L (BAG OF 10)	1	25615
85	BLOCK, MOUNTING, BASE LATCH	1	V2-AC-001
86	BRACKET, STOW LOCK SOLENOID (S/N's 50517 - present)	1	V2-AC-108
87-1	SOLENOID ASSY, 12V (S/N's 50517 - present)	1	V2-ES-127
87-2	SOLENOID ASSY, 24V (S/N's 50517 - present)	1	V2-ES-128
88	CLIP, SPRING, BASE LATCH	1	V2-AC-009
89-1	SCREW, PAN HEAD, 10-24 x 1/2 (BAG OF 10)	1	13304
89-2	SCREW, FLAT HEAD, 10-24 x 1/2, SST (BAG OF 10)	1	14426
90	NUT, HEX, NYLON INSERT, 10-24 (BAG OF 10)	1	13382
91	PIN, SPRING MOUNTING	1	V2-P1-095
92-1	KIT, REPLACEMENT SOLENOID, 12V (S/N's 32000-50516)	1	01238
92-2	KIT, REPLACEMENT SOLENOID, 24V (S/N's 32000-50516)	1	01239
93	SPRING, DOOR HELPER, .38OD X 3.5"	1	V2-SP-093
94	BUSHING, LATCH COVER	2	V2-BU-080
95	SCREW, HEX HEAD, 5/16-18 X 3/4" (BAG OF 10)	1	15901
96	SCREW, FLAT HEAD, 5/16-18 X 3/4 (BAG OF 10)	1	14499
97	SCREW, BUTTON HEAD, 1/4-20 X 1/2", SST (BAG OF 10)	1	15902
98	COVER, BASE LATCH (S/N's 50517 - present)	1	V2-CV-123
99	SCREW, HEX HEAD, 5/16-18 X .625 (BAG OF 10)	1	14495
100	WASHER, FLAT, .69OD x .34ID x .065 (BAG OF 10)	1	13350
101	TOUCH-UP SPRAY PAINT, CHARCOAL	1	25340
102	BUSHING, E-COVER MOUNT	2	V2-BU-081
103	SCREW, HEX HEAD, 1/4-20 X 1, GR5 (BAG OF 10)	1	14493
104	GROMMET, .30ID x .88OD x .44 (BAG OF 10)	1	23391
105-1	PIN, CONTROL CAM, (S/N's 62560 - present)	1	V2-PI-091
105-2	KIT, CONTROL CAM, RETROFIT	1	01287
106	RIVET, BLIND, STEEL 3/16 X 5/8 (BAG OF 10)	4	34519

** Item quantity is one each for s/n's 103,999 and below and quantity is two each for s/n's 104,000 and above.

This page intentionally left blank.

S-SERIES STANDEE HANDRAIL (EXPORT)
SERIAL NO's. 32000 - present

EXPORT
06/01/04

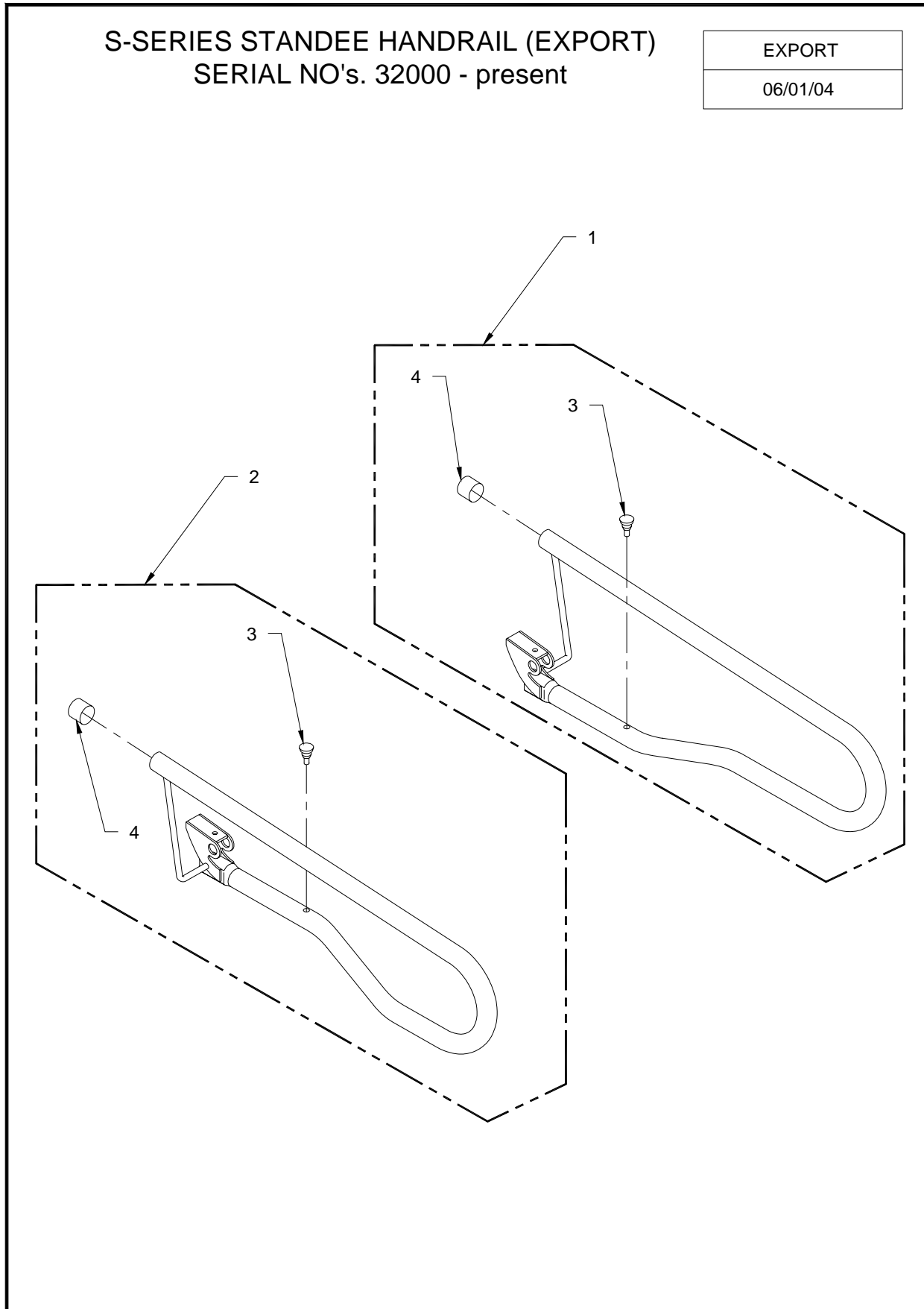

FIGURE 4-7: STANDEE HANDRAIL (EXPORT)

FIGURE 4-7: STANDEE HANDRAIL (EXPORT)
SERIAL NO's. 32000 - PRESENT

REF.	DESCRIPTION	QTY.	PART NO.
1	KIT, HANDRAIL ASSY, OFFSET, RH	1	VT-AC-364
2	KIT, HANDRAIL ASSY, OFFSET, LH	1	VT-AC-363
3	BUMPER, RUBBER (BAG OF 10)	2	20653
4	CAP, ROUND, BLACK	2	25550

This page intentionally left blank.

APPENDIX 1 LIFT SPECIFICATIONS

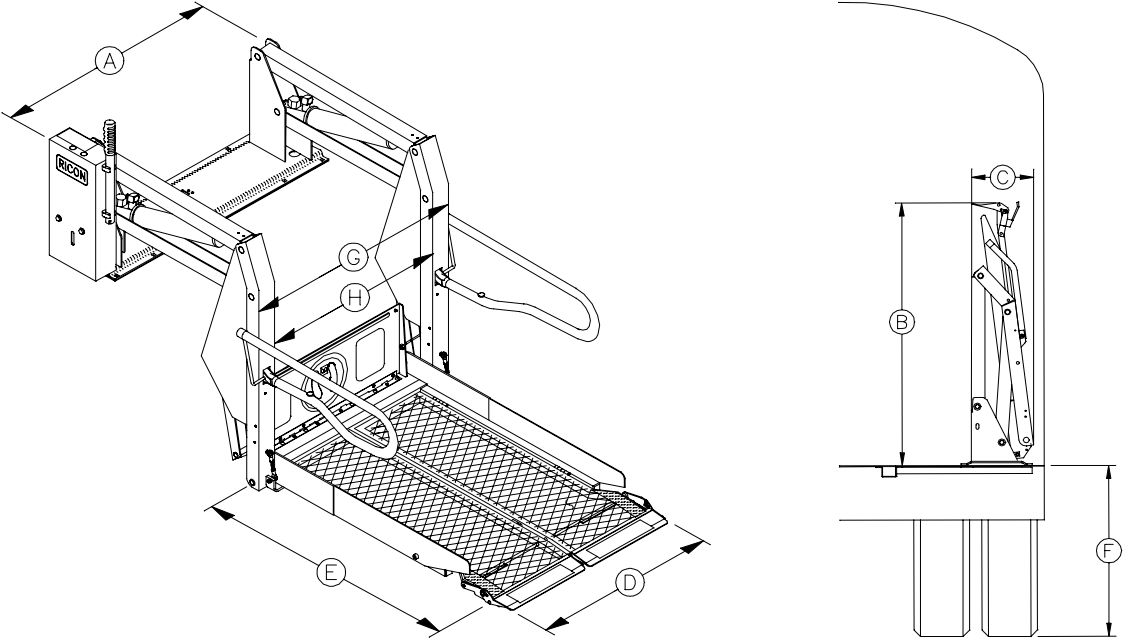
S-SERIES EXPORT USE WHEELCHAIR LIFT								
Power electro-hydraulic motor Pump rating @ 12 volts DC 65 amp avg/cycle, 1250 psi Pump rating @ 24 volts DC 32.5 amp avg/cycle, 1250 psi Hydraulic cylinders 2ea, 1.5", power-up/grav	Rated load capacity 800 lbs (364 kg) Manual backup (up) manual hand pump Manual backup (down) manual pressure release valve Lift Weight S-2030: 350 lbs (159 kg) S-5030: 375 lbs (170 kg)							
								
DIMENSIONS, inches (mm)								
MODEL	A Stationary frame width	B Height (folded)	C Installation depth (folded)	D Usable platform width	E Usable platform length	F Floor-to- ground travel	G Traveling frame width	H Clear entry width
S-2030	45 (1143)	55 (1397)	21.5 (546)	30 (762)	48 (1219)	42 (1067)	37.5 (953)	31 (787)
S-2034	45 (1143)	70 (1778)	21.5 (546)	30 (762)	63 (1600)	42 (1067)	37.5 (953)	31 (787)
S-2035	45 (1143)	55 (1397)	14 (356)	30 (762)	48 (1219)	42 (1067)	37.5 (953)	31 (787)
S-5030	45 (1143)	57.75 (1467)	21.5 (546)	30 (762)	48 (1219)	48 (1219)	37.5 (953)	31 (787)

-BACK TO TOP-

NOTES: