



INNOVATION IN MOBILITY

FoldOver^ä
FR2SS Series
Low-Floor Vehicle Access Ramp
for
Transit Buses

[PRINT ENTIRE MANUAL](#)

[TABLE OF CONTENTS](#)

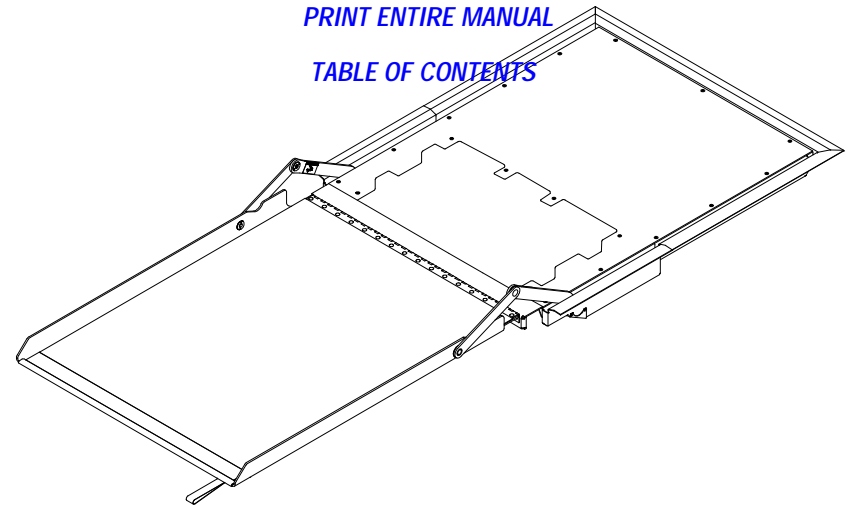

OPERATOR MANUAL

RICON authorized service technicians must install and service this RICON product.

Operator must refer to this manual for operating instructions, and retain it for future reference by authorized service technicians.

Customer Name: _____

Installing Dealer: _____

Date Installed: _____

Serial Number: _____

REVISION RECORD

REVISION	PAGES	DESCRIPTION	ECR/ECO
32DFR107. A	ALL	Initial Release	N/A

TABLE OF CONTENTS

<u>Chapter</u>	<u>Page</u>
I. FOLDOVER RAMP INTRODUCTION.....	1-1
A. RICON PRODUCT SUPPORT.....	1-1
B. RICON TWO-YEAR LIMITED WARRANTY	1-1
C. SHIPPING INFORMATION	1-3
D. GENERAL SAFETY PRECAUTIONS.....	1-3
II. FOLDOVER RAMP DESCRIPTION	2-1
A. RAMP FEATURES	2-1
1. INTERLOCK SUPPORT	2-1
2. AUDIBLE ALERT	2-1
3. RAMP CONTROL PANEL	2-1
B. RAMP CLEARANCE AND CAPACITY	2-2
C. MAJOR COMPONENT DESCRIPTIONS	2-3
III. FOLDOVER RAMP OPERATING INSTRUCTIONS.....	3-1
A. SAFETY PRECAUTIONS.....	3-1
B. DAILY INSPECTION	3-2
C. RAMP OPERATION	3-2
1. OPERATING RAMP WITH CONTROL PANEL.....	3-3
2. OPERATING RAMP MANUALLY	3-5
IV. FOLDOVER RAMP MAINTENANCE.....	4-1
A. MAINTENANCE SCHEDULE	4-1
B. RAMP DECALS	4-2

This page intentionally left blank.

[BACK TO FRONT COVER-](#)

[-GO TO NEXT CHAPTER-](#)