

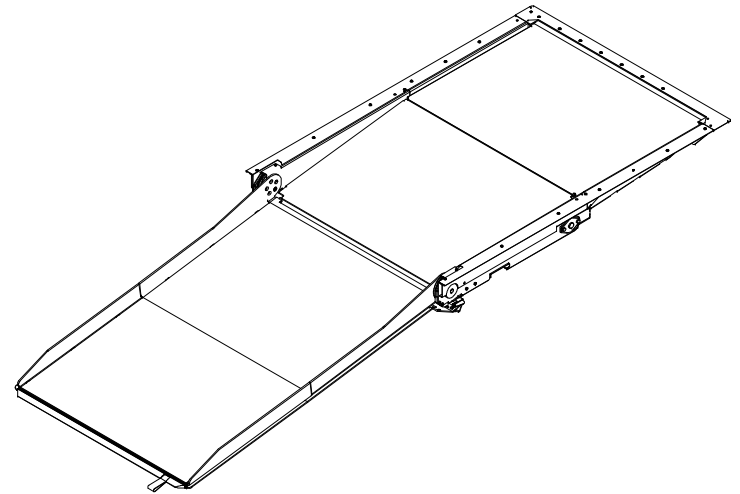

Ricon[®]
A **Wabtec** company

FoldOver[®]
621R-Series 1:6
Low-Floor Bus Ramp



Operator Manual

-PRINT-



Ricon[®]
A **Wabtec** company

09/20/11

32D62101.A

©2011 RICON CORPORATION
All Rights Reserved

-HOME-

U.S. and Foreign patents pending
Printed in the United States of America

RICON dealers or qualified service technicians must install and service this RICON product.

Operator must refer to this manual for operating instructions, and retain it for future reference by dealers or qualified service technicians.

Customer Name: _____

Installing Dealer: _____

Date Installed: _____

Serial Number: _____

REVISION RECORD

REVISION	PAGES	DESCRIPTION	ECR/ECO
32D62101. A	ALL	NEW RELEASE.	

TABLE OF CONTENTS

<u>Chapter</u>	<u>Page</u>
I. FOLDOVER 1:6 RAMP INTRODUCTION	1-1
RICON PRODUCT SUPPORT	1-1
RICON TWO-YEAR LIMITED WARRANTY.....	1-1
SHIPPING INFORMATION.....	1-3
GENERAL SAFETY PRECAUTIONS	1-3
II. FOLDOVER 1:6 RAMP DESCRIPTION	2-1
A. RAMP FEATURES	2-1
1. INTERLOCK SUPPORT	2-1
2. AUDIBLE ALERT	2-1
3. RAMP CONTROL PANEL	2-1
B. MAJOR COMPONENT DESCRIPTIONS	2-2
III. FOLDOVER 1:6 RAMP OPERATING INSTRUCTIONS.....	3-1
A. SAFETY PRECAUTIONS	3-1
B. DAILY INSPECTION.....	3-2
C. RAMP OPERATION	3-2
1. OPERATING RAMP WITH CONTROL PANEL.....	3-3
2. OPERATING RAMP MANUALLY	3-5
IV. FOLDOVER 1:6 RAMP MAINTENANCE	4-1
A. MAINTENANCE SCHEDULE	4-1
B. RAMP DECALS	4-2

This page intentionally left blank.

I. FOLDOVER 621R-SERIES 1:6 RAMP INTRODUCTION

This operator manual contains an introduction, a product description, operating instructions, and a maintenance schedule for the Ricon FoldOver® 621R-Series 1:6 Low-Floor Bus Ramp when installed in transit vehicles.

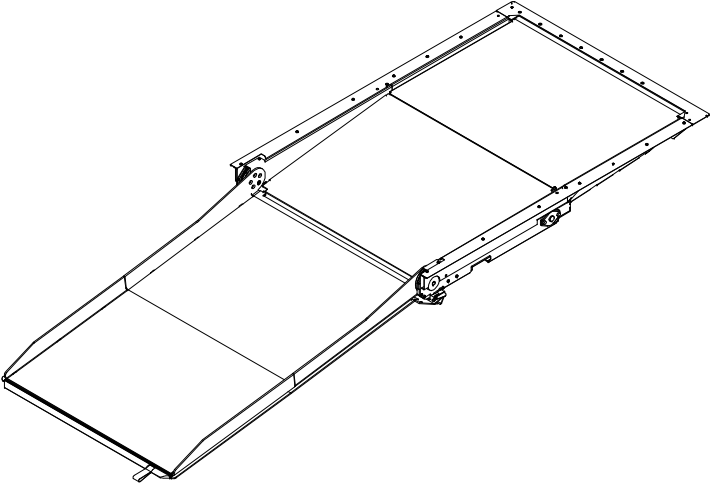

A. RICON PRODUCT SUPPORT

If you have questions about this manual, or you need additional copies, please contact Ricon Product Support at one of the listed locations. Also, refer to the Ricon worldwide website at: www.riconcorp.com

Ricon Corporation
7900 Nelson Road
Panorama City, CA 91402

Telephone:..... (818) 267-3000
(outside 818 area code and in US)..... (800) 322-2884

Vapor Ricon Europe Ltd.
Meadow Lane
Loughborough, Leicestershire
United Kingdom, M43 7EF
Telephone:..... 0044 (0) 1509 635 920
Website..... www.riconuk.com

B. RICON TWO-YEAR LIMITED WARRANTY

The following warranty provides two years of limited coverage for the Ricon FoldOver® 621R-Series 1:6 Low-Floor Bus Ramp.

RICON FOLDOVER® 1:6 RAMP TWO-YEAR LIMITED WARRANTY

Ricon Corporation (Ricon) warrants to the original purchaser of this product that Ricon will repair or replace, at its option, any parts that fail because of defective material or workmanship as follows:

- Repair or replace parts for a period of two years starting from the in-service date. Obtain a complete list of parts covered by this warranty from Ricon Product Support.
- Labor costs for specified parts replaced under this warranty for a period of two years from date put into service. A Ricon rate schedule determines parts covered and labor allowed.

This Warranty Does Not Cover:

- Malfunction or damage of product parts caused by accident, misuse, lack of proper maintenance, neglect, improper adjustment, modification, alteration, mechanical condition of vehicle, road hazards, overloading, failure to follow operating instructions, or acts of Nature (i.e., weather, lightning, flood).

NOTE: Ricon recommends that this product be inspected by a Ricon dealer or qualified service technician at least once every six months, or sooner, if necessary. Any required maintenance or repair should be performed at that time.

WARNING!

THIS PRODUCT HAS BEEN DESIGNED AND MANUFACTURED TO EXACT SPECIFICATIONS. ANY MODIFICATION OF THIS PRODUCT CAN BE DANGEROUS.

This Warranty is Void If:

- The product is not installed and maintained by a Ricon dealer or qualified service technician.
- The product is modified, in any respect from its original design, without written authorization from Ricon.

Ricon disclaims liability for any personal injury or property damage that results from operation or use of a Ricon product that is modified from the original Ricon design. No person or company is authorized to change the design of this Ricon product without written authorization from Ricon.

The Ricon obligation under this warranty is exclusively limited to the repair or exchange of parts that fail within the applicable warranty period.

Ricon assumes no responsibility for expenses or damages, including incidental or consequential damages. Some states do not allow the exclusion or limitation of incidental or consequential damages, so the above limitation or exclusion may not apply.

Important: The warranty registration card must be completed and returned to Ricon within 20 days after installation of this Ricon product to validate the warranty. The warranty is not transferable.

The warranty gives specific legal rights. There may be other rights that vary in each state.

C. SHIPPING INFORMATION

Check the received product for freight damage. Make damage claims immediately to the freight carrier.

Be sure the ramp assembly contains all items listed on the included bill-of-material. Please report any missing items immediately to Ricon Product Support. Return the completed warranty and owner registration cards to Ricon within 20 days to validate the warranty.

D. GENERAL SAFETY PRECAUTIONS

Adhere to the following safety precautions during installation, operation, service, and maintenance:

- Do not attempt installation, maintenance, repairs, or adjustments without the presence of a person capable of rendering aid.
- Administer first aid or seek medical attention immediately for any injury, no matter how slight.
- Wear protective eye shields and appropriate clothing at all times.
- Exercise caution when operating ramp. Be certain hands, feet, legs, and clothing are out of the ramp path as it unfolds.
- Thoroughly understand operating instructions before using ramp.
- Inspect ramp before loading passengers. Do not use ramp if it exhibits any unusual noise or movement.
- Do not exceed ramp weight capacity of 1000 lbs (453kg).
- Keep others clear during ramp operation.
- The ramp requires regular maintenance. Ricon recommends a thorough inspection every six months. Maintain the product at its highest level of performance.

This page intentionally left blank.

II. FOLDOVER 621R-SERIES 1:6 RAMP DESCRIPTION

The Ricon FoldOver® 621R-Series 1:6 Low-Floor Bus Ramp is installed in the entrance area of a transit vehicle and folds into the floor when not in use. The ramp is provided to assist passengers that use mobility-aid equipment or passengers who have difficulty climbing steps. All 621R-Series ramps have a 1000 lb (453kg) load limit.

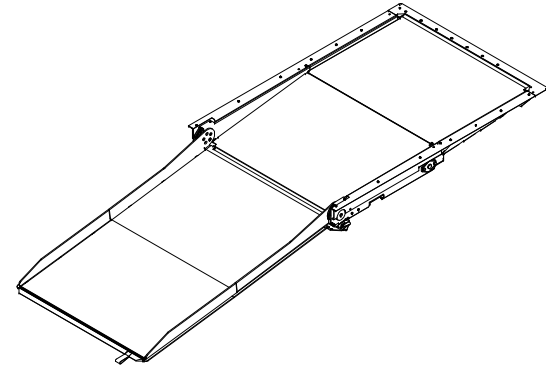

The FoldOver® 621R-Series 1:6 Low-Floor Bus Ramp has the reduced ramp slope preferred by passengers that utilize mobility-aid equipment or passengers who have difficulty climbing steps. The innovative design also provides a smooth, safe operation and requires minimal maintenance.

A. RAMP FEATURES

1. INTERLOCK SUPPORT

The ramp electronic circuits can be connected to the vehicle interlock circuitry to keep the vehicle at a stop whenever the ramp is deployed. The ramp circuitry senses the position of the ramp (stowed or deployed) and makes this information available to the vehicle. Vehicle interlock circuits typically require that the following conditions be met before ramp operating power is made available to the ramp:

- Vehicle is safely parked and parking brake is ON.
- Transmission is in neutral.
- Vehicle doors adjacent to the ramp are open.

2. AUDIBLE ALERT

NOTE: This feature is optional and may not have been connected during ramp installation.

The ramp supports an audible alert device that sounds while the ramp is in motion.

3. RAMP CONTROL PANEL

Refer to **Figure 2-1**. Ricon typically does not provide a control panel for the ramp. However, the ramp can be operated with one similar to that shown (the actual panel appearance will

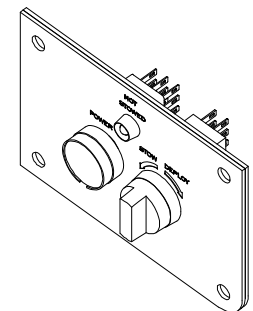
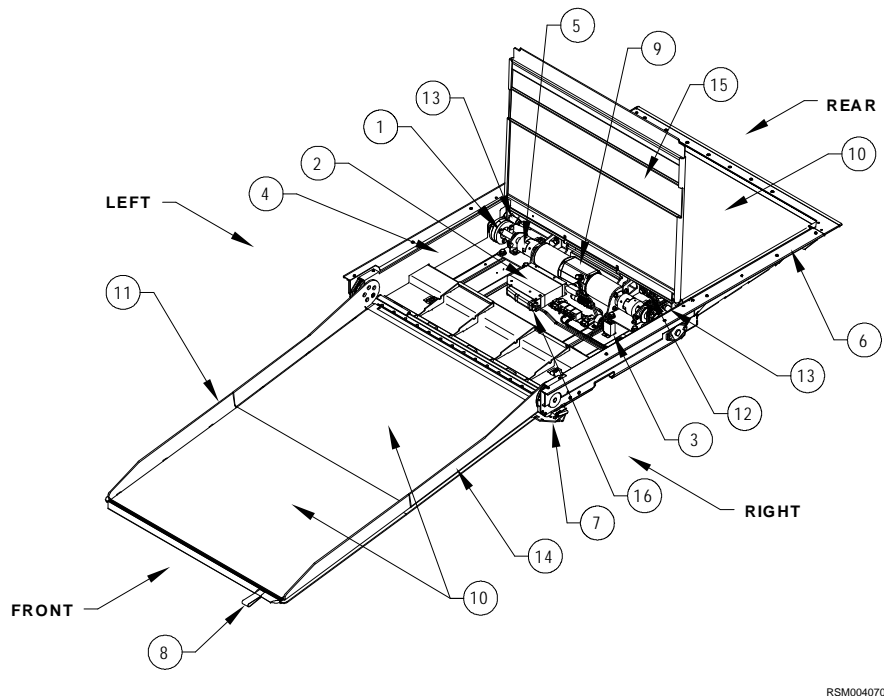

FIGURE 2-1: TYPICAL CONTROL PANEL

vary between transit authorities and vehicles). The control panel is normally installed in the driver area. It should have a power ON/OFF switch, a power on indicator light, and a spring-loaded, three-position ramp control switch (center position is off). The ramp receives power from the vehicle when the interlock conditions are met and the control panel power switch is ON. The control panel can then be used to transmit deploy or stow signals to the ramp.

B. MAJOR COMPONENT DESCRIPTIONS

Figure 2-2 shows major components of the Ricon FoldOver 621R-Series 1:6 Low-Floor Bus Ramp. A description of each component is provided in Table 2-2.



RSM0040700

FIGURE 2-2: MAJOR COMPONENTS OF THE FOLDOVER 1:6 RAMP

TABLE 2-2: MAJOR RAMP COMPONENTS	
Item	Description
Front, Rear, Left and Right	Reference point from outside the vehicle looking inward.
1	Adjustable Coupler - Use for adjustment and alignment of chain sprocket.
2	Controller – Translates electrical commands from bus control panel into signals that control ramp electro-mechanical components. Monitors ramp position and drives counter.
3	Counter – Counts each cycle.
4	Chain Assembly
5	Couplings - (Left & Right) Transmits rotary motion and attaches the drive motor shaft assemblies to the dual gearboxes.
6	Flange Kit - Perimeter trim pieces that are installed after the ramp has been installed in vehicle.
7	Front Cover - Front edge of ramp that opens and closes when platform is deployed or stowed.
8	Lifting Strap - Use to assist in manual deploy or stow ramp.
9	Motor Drive System - Electro-mechanical motor-gearbox combination used to operate the ramp.
10	Non-Slip Surface – Flooring over which passengers traverse.
11	Platform Assembly - Area where passengers traverse over to enter and exit vehicle.
12	Positive Connection Block – Connection through which the ramp receives power from vehicle.
13	Proximity Sensors - Magnetic sensor devices that send signals to the ramp controller to indicate when the ramp is fully stowed (locks electromagnets) or deployed (unlocks electromagnets).
14	Ramp Tray Barrier - Left and Right side barrier of platform.
15	Slanted Floor Plate (Access Cover) - Portion of ramp that passenger traverses over to enter and exit vehicle which also provides access to electro-mechanical ramp components.
16	Harness – Integrates conduits, relays, etc.

This page intentionally left blank.

III. FOLDOVER 621R-SERIES 1:6 RAMP OPERATING INSTRUCTIONS

Read the operating instructions carefully before operating the Ricon FoldOver® 621R-Series 1:6 Low-Floor Bus Ramp in a transit vehicle.

A. SAFETY PRECAUTIONS

Comply with these safety precautions:

- Perform the daily inspection described in **Table 3-1** (refer to **Section B** in this chapter).
- Refer to **Figure 3-1**. Do not deploy ramp when vehicle is parked on a sloping surface or a steeply crowned roadway. The increased ramp angle may pose a risk to ramp users.

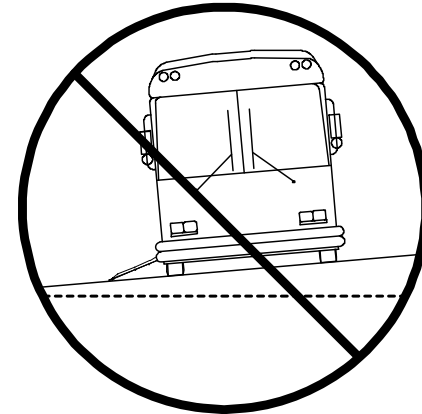

RSM0015100

FIGURE 3- 1: RAMP MIDPOINT DURING DEPLOY

- The ramp operator must supervise ramp while it is in use. Be certain passengers using the ramp board and exit the vehicle slowly and carefully.
- Check area around ramp for objects that might interfere with ramp operation.
- Inspect ramp before loading passengers. Do not use ramp if it exhibits unusual noise or erratic movement.
- Keep others at a safe distance when the ramp is deploying or stowing.
- Do not allow anyone (including operator) near moving ramp parts.
- Be certain mobility equipment fits ramp (outside width of mobility equipment must be less than ramp width).
- Passengers using mobility equipment (e.g., wheelchairs and scooters) must travel facing **forward** on ramp when they enter and exit; **it is never safe to travel backwards on ramp.**
- Ramp users must enter and exit vehicle one at a time (with or without mobility equipment). Do not exceed the ramp load capacity of 1000lbs (453kg).
- Caution ramp users to use care during wet conditions; shoes, wheels, brakes, etc. may slip on wet ramp surface.
- Do not allow anyone to play, sit, or rest on or near ramp.
- Supervise ramp while deployed. Retract ramp to its stowed position when not in use.

- Read and comply with warning labels affixed to ramp.

B. DAILY INSPECTION

Check ramp daily following the Daily Inspection outlined in **Table 3-1**. Meet all inspection criteria before allowing passengers to use ramp.

TABLE 3-1: DAILY INSPECTION	
Inspection Points	Check
Ramp control panel (typical)	<ul style="list-style-type: none"> ▪ Power ON/OFF switch operates correctly. ▪ Power On indicator illuminates when Power ON/OFF switch is ON. ▪ DEPLOY and STOW switches operate correctly.
Ramp and surrounding area	<ul style="list-style-type: none"> ▪ No indication of unusual noise or erratic movement when ramp is deploying or stowing. ▪ Vestibule area must be clear of loose objects and must be free of debris.
Ramp non-slip surface	<ul style="list-style-type: none"> ▪ Surface must be clean, and free of slippery or sticky substances that could compromise user safety.

C. RAMP OPERATION

 WARNING!
<p>IMPROPER USE OF RAMP CAN RESULT IN PERSONAL INJURY. OPERATOR MUST READ AND FOLLOW THE OPERATING INSTRUCTIONS IN THIS MANUAL. ADDITIONAL COPIES OF THIS MANUAL ARE AVAILABLE FROM:</p> <p style="text-align: center;">RICON CORPORATION 7900 NELSON ROAD PANORAMA CITY, CA 91402 (818) 267-3000 or (800) 322-2884 (in US)</p> <ul style="list-style-type: none"> ▪ CHECK RAMP AND RELATED COMPONENTS BEFORE USE FOR PROPER FUNCTION, REQUIRED MAINTENANCE, OR DAMAGE. DO NOT USE RAMP IF A PROBLEM EXISTS, AND SEEK A RICON DEALER OR QUALIFIED SERVICE TECHNICIAN FOR INSPECTION. ▪ DO NOT EXCEED RAMP LOAD CAPACITY OF 1000 POUNDS (453 KILOGRAMS). ▪ THE RAMP IS DESIGNED FOR PERSONS USING MOBILITY-AID EQUIPMENT OR FOR PASSENGERS THAT CANNOT CLIMB STEPS. <p>RICON CORPORATION DISCLAIMS LIABILITY FOR DAMAGE OR PERSONAL INJURY RESULTING FROM IMPROPER INSTALLATION, MODIFICATION TO THE RAMP OR OTHER COMPONENTS, LACK OF MAINTENANCE OR REPAIR, NEGLIGENCE, ABUSE OR FAILURE TO FOLLOW THE OPERATING INSTRUCTIONS.</p>

- Perform the daily safety check described in **Table 3-1** before putting vehicle into service. If a problem exists, do not use ramp; seek a Ricon dealer or qualified service technician for repair.

- Comply with the Safety Precautions at the beginning of this chapter.
- Control of the vehicle transmission and brakes is removed while ramp is deployed; control is restored when ramp is fully stowed.

1. OPERATING RAMP WITH A CONTROL PANEL

a. Prepare Vehicle

- 1.) Park vehicle where deployment and use of ramp is safe.
- 2.) Apply parking brake.
- 3.) Put transmission in neutral and open door adjacent to ramp.
- 4.) You can deploy ramp **only** when the parking brake is set, the transmission is in neutral, and the vehicle door adjacent to the ramp is open.
- 5.) Caution people inside and outside to clear the area because the ramp is about to deploy.

b. Deploy Ramp

 WARNING!
MAKE SURE PEOPLE ARE A SAFE DISTANCE FROM RAMP AREA BEFORE OPERATING.

- 1) Apply power to ramp by activating power switch on ramp control panel; Power On indicator should illuminate.
- 2) Refer to **Figure 3-2**. Press and hold the DEPLOY button until front edge of ramp touches ground level. Motor drive system stops automatically when front edge of ramp touches the ground.

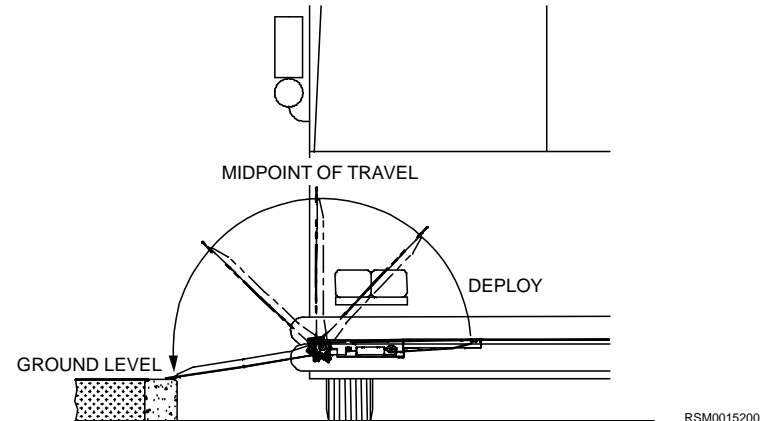

FIGURE 3- 2: RAMP DURING DEPLOY

- NOTE:** Pressing the DEPLOY button will have no further affect after motor drive system cutoff.
- NOTE:** The vehicle audible alert will sound (if connected) while ramp is in motion.
- NOTE:** You can reverse the direction of ramp movement at any time by pressing the STOW button.

NOTE: Ramp users are required to enter and exit vehicle **one at a time**. Passengers using mobility equipment (e.g., wheelchairs and scooters) should **travel facing forward** when on ramp.

c. **Stow Ramp**



- 1) Refer to **Figure 3-3**. Press and hold the STOW button. Hold button until ramp is fully stowed and motor drive system shuts off.

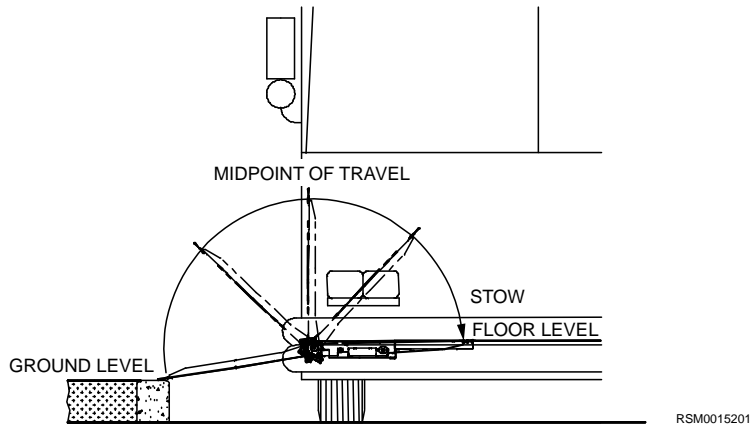

FIGURE 3- 3: RAMP DURING STOW

NOTE: The audible alert sounds, if connected, while ramp is in motion.

NOTE: You can reverse the direction of ramp movement at any time by pressing the DEPLOY button.

NOTE: Motor works as brake after ramp has passed 90°.

NOTE: Ramp users are required to enter and exit vehicle **one at a time**. Passengers using mobility equipment (e.g., wheelchairs and scooters) should **travel facing forward** when on ramp.

- 2) Close vehicle door.

NOTE: Be certain ramp is fully stowed before you close door or operate vehicle.

2. MANUAL OPERATION

a. Prepare Vehicle

WARNING!

COMPLY WITH SAFETY PRECAUTIONS AT BEGINNING OF THIS CHAPTER.

- 1.) Park vehicle in a safe, level area. Lower vehicle, if this function is available and working.
- 2.) Apply parking brake.
- 3.) Put transmission in neutral, and open door adjacent to ramp.

b. Deploy Ramp

- 1) Turn power to ramp OFF. Energized ramp will not allow for manual deployment.
- 2) Grasp lifting strap, located on ramp platform, then pull to deploy platform from stowed position.

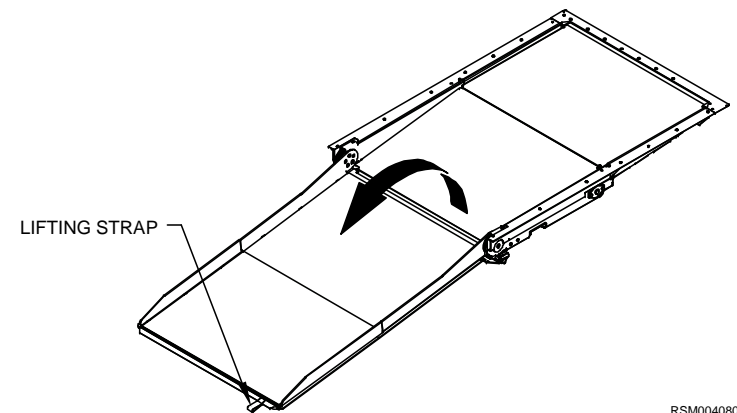

FIGURE 3- 4: MANUAL DEPLOY

- 3) Lift ramp platform sufficiently to obtain a handhold on front edge of ramp.

WARNING!

KEEP YOUR BACK VERTICAL AND LEGS TOGETHER WHEN LIFTING RAMP.

- 4) Grip front edge of ramp with both hands, and begin to slowly unfold from its stowed position.

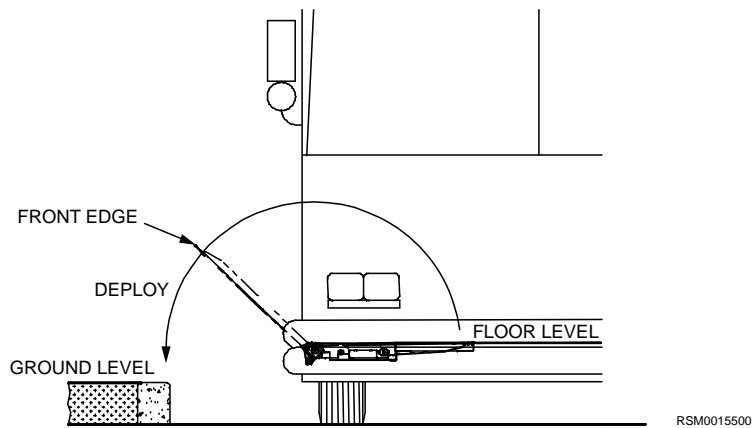

FIGURE 3- 5: RAMP DURING MANUAL DEPLOY

- 5) Unload passengers. Passengers using mobility-aid equipment (e.g., wheelchairs and scooters) should **travel forward** when on ramp.

c. Stow Ramp

⚠ WARNING!
COMPLY WITH SAFETY PRECAUTIONS AT BEGINNING OF THIS CHAPTER.

- 1) Grasp lifting strap at front edge of ramp (refer to **Figure 3-4**).

⚠ WARNING!
AVOID PINCHING YOUR FINGERS WHEN MANUALLY LIFTING RAMP. KEEP YOUR BACK VERTICAL AND LEGS TOGETHER WHEN LIFTING RAMP.

- 2) Lift ramp slightly to obtain a handhold on front edge of ramp.

⚠ CAUTION!
Do not use excessive force when lifting ramp because damage to the ramp components could result.

- 3) Lift ramp and begin to push it toward the stowed position.

NOTE: Be certain ramp is fully stowed before closing door or operating vehicle.

IV. FOLDOVER 621R-SERIES 1:6 RAMP MAINTENANCE

A. MAINTENANCE SCHEDULE

Regular maintenance and inspection of the Ricon FoldOver® 621R-Series 1:6 Low-Floor Bus Ramp provides optimum performance and reduces the need for repairs. Maintain the ramp as directed in **Table 4-1**, adhering to the cautions noted below. Perform ramp maintenance more frequently during heavy use (more than 20 cycles per day). Refer to the Ricon FoldOver 621R-Series 1:6 Low-Floor Bus Ramp Service Manual 32D62102 for complete maintenance and troubleshooting information.

 CAUTION!
~ This Ricon product is complex ~
Do the maintenance and repairs required during the warranty period at a Ricon facility. Improper maintenance, use of non-Ricon replacement parts, or product modification will void warranty and can result in unsafe operating conditions. We recommend that a Ricon facility continue maintenance inspections when warranty expires.

TABLE 4-1: MAINTENANCE SCHEDULE	
Inspection Point	Action
– 6,000 MILE INSPECTION –	
Electrical system	<ul style="list-style-type: none"> • Check all cables and fittings; tighten or replace as necessary. • Check chain spring assembly for wear or missing parts. <p>NOTE: Refer to Service Manual for details.</p>
Cover Fasteners	Check all threaded fasteners for looseness, and retighten as necessary.
Ramp interior (for debris)	Check ramp interior area and remove accumulated dirt and debris.
Non-slip surfaces	Check for excessive wear, as well as loose edges; replace as necessary.
Decals	Check for illegibility or looseness; replace as necessary.
(continued)	

Inspection Point	Action
- 12,000 MILE INSPECTION -	
Wiring harnesses	<ul style="list-style-type: none"> ▪ Check wiring insulation for heavy abrasion or cuts; replace as necessary. ▪ Check connectors for looseness. Secure as necessary. <p>NOTE: Harnesses are routed below ramp floor and between ramp assembly and vehicle.</p>
Cover Fasteners	Check all threaded fasteners for looseness, and retighten as necessary.
- 24,000 MILE INSPECTION -	
Chain Drive Assembly	Grease or oil to lubricate parts is NOT recommended. Keep components clean and free of debris
END OF TABLE	

B. RAMP DECALS

Refer to **Figure 4-1**. Inspect decals at intervals in **Table 4-1**. Inspect for chipping, peeling, fading, and illegibility. Replace a decal by ordering the part number shown in figure, and applying it where shown. Surface must be clean and free of debris before applying decal.

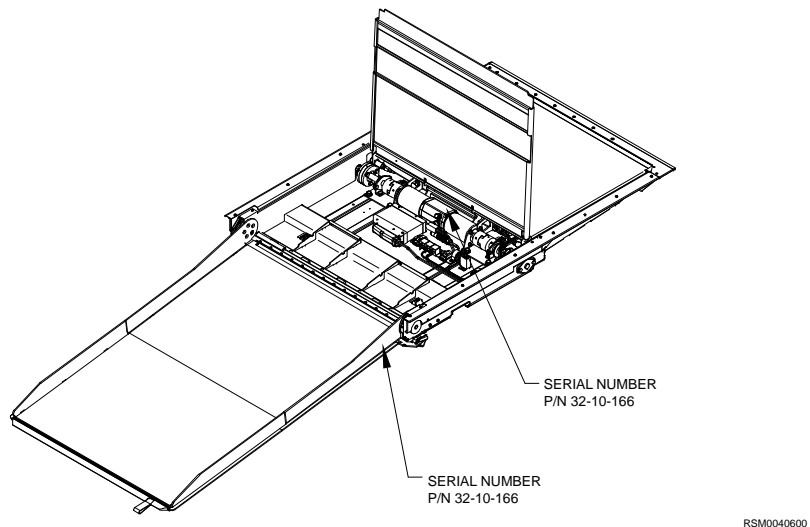

FIGURE 4-1: DECAL LOCATIONS